

ADAPTERS, IN SERIES

SMA, DC - 26.5 GHz, Bulkhead Mount

SPECIFICATIONS:

Models: 5211, 5218

RoHS
Compliant

Electrical:	
Frequency Range _____	DC - 26.5 GHz
Standard Freq. Values _____	18 & 26.5 GHz
VSWR	
DC - 4 GHz _____	1.05:1 Max.
4 - 8 GHz _____	1.10:1 Max.
8 - 18 GHz _____	1.15:1 Max.
18 - 26.5 GHz _____	1.30:1 Max.
Nominal Impedance _____	50 Ohms
Operating Temp Range _____	-55°C to +125°C
Mechanical:	
Connectors _____	Passivated Stainless Steel
<small>Mates with MIL-STD-348</small>	
Conductors _____	Gold Plated Beryllium Copper
Nut & Washer: _____	Passivated Stainless Steel
O-Ring _____	Silicone Rubber

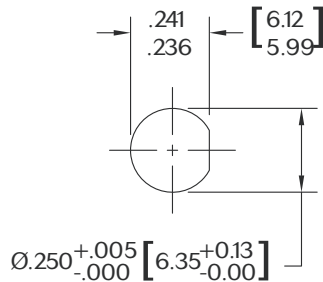

Recommended Mounting Hole

Model Number: 5211

Frequency Range _____ DC - 18 GHz

Model Number: 5218

Frequency Range _____ DC - 26.5 GHz

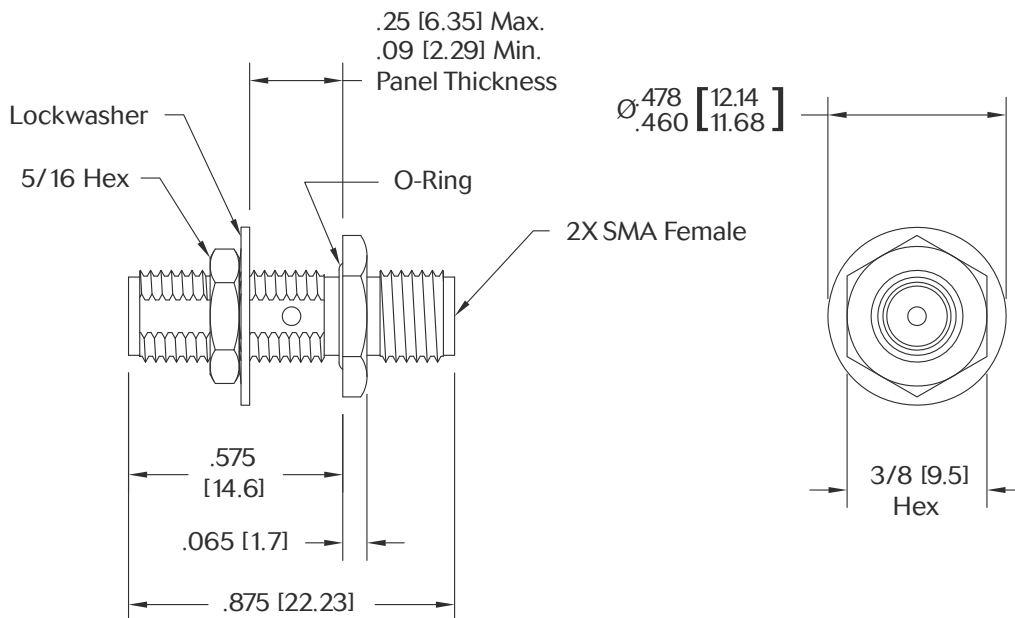

Panel Nut, Lock Washer & O-Ring are Shipped Unassembled

Note: Dimensions in Brackets are Expressed in Millimeters and are for Reference Only.
Design specifications are subject to change without notice.
Contact factory for technical specifications before purchasing or use.

5211: REV G



Aeroflex / Inmet, Inc. • 300 Dino Drive, Ann Arbor, MI 48103 • U.S.A.
888-244-6638 or 734-426-5553 • FAX: 734-426-5557
www.aeroflex.com/inmet • inmet@aeroflex.com