



HIGH PEAK TO AVERAGE RATIO OFDM BLOCK UPCONVERTER

IF Input 25MHz~800MHz

RF Output 1.70GHz~1.90GHz



Summary

RFBUC2G2GA/B up-converter unit uses the phase lock technology, and it uses the crystal oscillator with temperature compensating function as the referenced signal of PLL, what's more, it uses the low phase noise national semiconductor LMX2434TMX as the frequency synthesizer chip of PLL. So the frequency of its inner part LO has a good stability in a wider temperature range.

RFBUC2G2GA up-converter unit can ensure that the much lower IF (intermediate frequency) input is valid when the output range of RF (radio frequency) is quite broad, since it adopts the double frequency conversion scheme .

General Specification

IF input frequency: 25MHz~200MHz or 200MHz~800MHz

RF output frequency: 1.70GHz~1.90GHz

Output power up to 2W CW.

Frequency stability 2×10^{-6} / Hour

Frequency hopping <10ms / 5MHz

Control interface: USB USART (TTL control)

High linearity low spurious in / out band

Handle high peak to average ratio signal such as OFDM, QPSK, DSSS signal.

Ideal for point to point radio station.

Small package, high mobility.

Electrical Specifications

IF input range	25MHz~200MHz (RFBUC2G2GA) 200MHz~800MHz (RFBUC2G2GB)	RF output Frequency	1.70GHz~1.90GHz
P1dB	+33dBm	Out IP3:	+43dBm
Conversion Gain:	50dB \pm 0.5dB $\Delta G/\Delta T=0.03\text{dB}/^\circ\text{C}$	In/ Out VSWR:	1.5 : 1
Flatness:	+/-1.0dB max.	Frequency step	0.5MHz
In-Band spurious	60dBc min. (-20dBm input @ 4.7GHz)	Out-Band Spurious	35dBc @ 840MHz (-25dBm input) 30dBc @ 1680MHz (-25dBm input)
LO Phase Noise	-110dBc/Hz (100KHz offset)	Locking speed	10ms / 5MHz
Input Power	-10dBm (Max)	DC Voltage:	DC type: +12V 1.2A typ. 1.5A max. AC Type: 110V/220V AC 60Hz

Mechanical and Environmental Specifications

Operation Temperature:	-40°C to 85°C base plate	Mechanical shock	30G, 11mSec half sin wave, 3 axis both directions
Vibration:	14.2g RMS (15-2000Hz) functional	Humidity	95% relative humidity, 65°C 96Hour
	16.2g RMS (15-2000Hz) endurance, 1 hour /axis	MTBF	50000 hour min
Connectors:	RF SMA-F / N-F Removable	Case:	Conductive no paint
	Supply RFI filter solder Pin (or 110V AC power plug)	Dimension Size (L x W x H):	4.92" x 3.35" x 0.63" (DC model) 7.87" X 4.72" X 1.00" (AC model)

OFDM FREQUENCY BLOCK UPCONVERTER 4.45GHZ-5.50GHZ



1.7-1.9GHz UPCONVERTER TESTING TABLE

		1.7GHz					
Input Frequency (MHz)	IF input Level (dBm)	Output Level (dBm)	In-Band (1.7-1.9GHz) Spurious Level (dBc) min	Out-Band (0.1-1.7GHz) Spurious Level (dBc) min	Out-Band (1.9-2.5GHz) Spurious Level (dBc) min	P1dB (dBm)	Current (A)
36MHz Input	-25dBm	24.9	-	40@840M, 31@1680M		33.5	0.51
	-20dBm	30.5	31@1725M	42@875M, 21@1680M			0.72
	-16dBm	33.5	16@1725M, 29@1745M	36@840M, 17@1680M			0.92
		1.8GHz					
Input Frequency (MHz)	IF input Level (dBm)	Output Level (dBm)	In-Band (1.7-1.9GHz) Spurious Level (dBc) min	Out-Band (0.1-1.7GHz) Spurious Level (dBc) min	Out-Band (1.9-2.5GHz) Spurious Level (dBc) min	P1dB (dBm)	Current (A)
36MHz Input	-25dBm	24.2	46@1725M	34@125M, 32@1680M	45@1924M	33.2	0.46
	-20dBm	30.4	49@1725M	26@125M, 25@1680M	31@1924M		0.69
	-16dBm	33.2	55@1725M, 53@1875M	30@125M, 20@1680M	21@1924M, 33@2048M		0.91
		1.9GHz					
Input Frequency (MHz)	IF input Level (dBm)	Output Level (dBm)	In-Band (1.7-1.9GHz) Spurious Level (dBc) min	Out-Band (0.1-1.7GHz) Spurious Level (dBc) min	Out-Band (1.9-2.5GHz) Spurious Level (dBc) min	P1dB (dBm)	Current (A)
36MHz Input	-25dBm	23.5	45@1830M	36@840M, 30@1680M		33.3	0.44
	-20dBm	30.3	47@1830M	24@225M, 24@1680M	30@2124M		0.63
	-16dBm	33.3	52@1830M	21@225M, 15@1680M	21@2124M, 44@2349M		0.87



BLOCK DIAGRAM

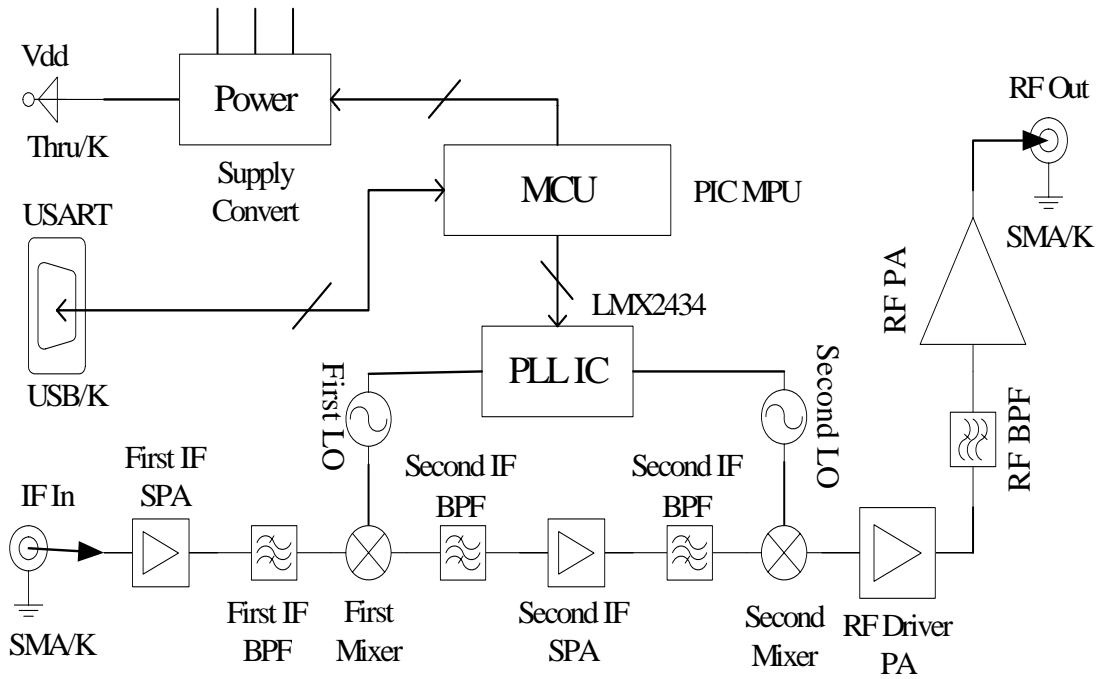

MECHANICAL DRAWING

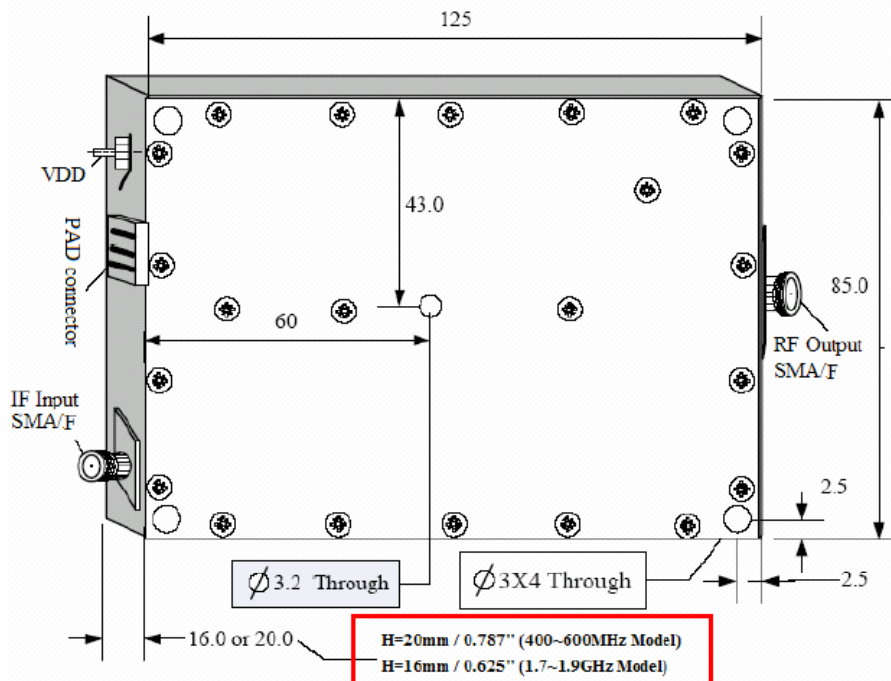

FREQUENCY BLOCK UPCONVERTER 1.7GHZ-1.9GHZ



Appendix A LAB TEST VERIFICATION SYSTEM DEMONSTRATION

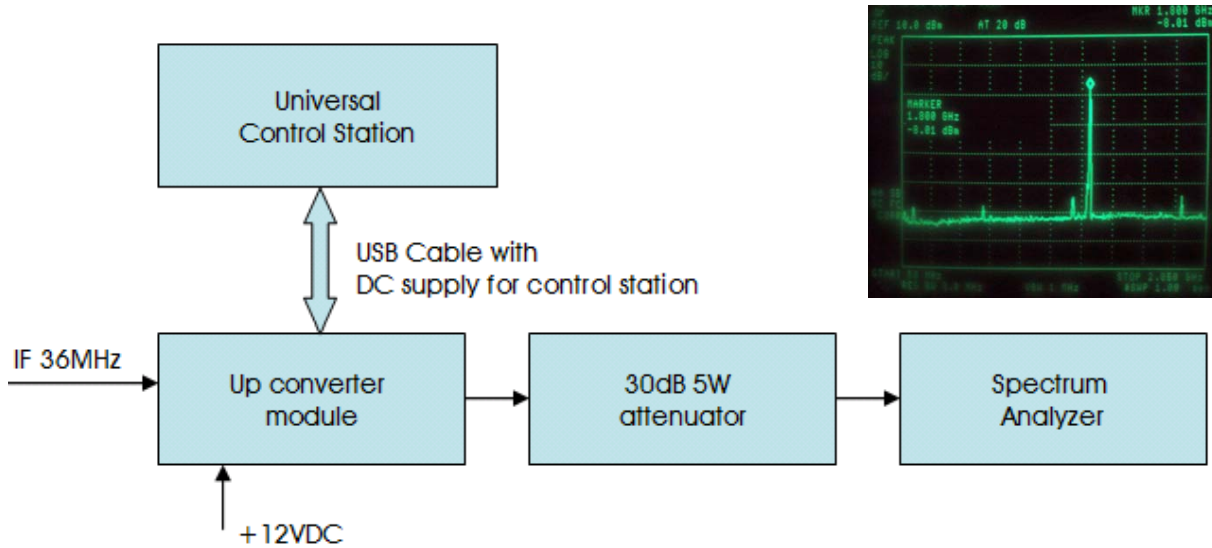

- Heat sink must be attached during operation.
- Due to high output power, the attenuator must be connected between unit and spectrum analyzer.

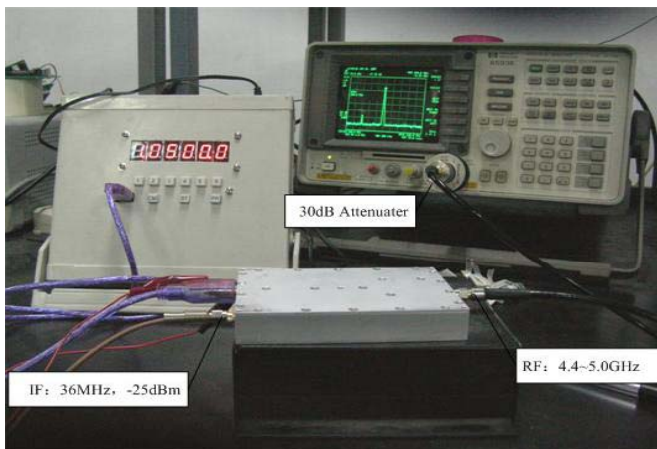

Universal Control Station

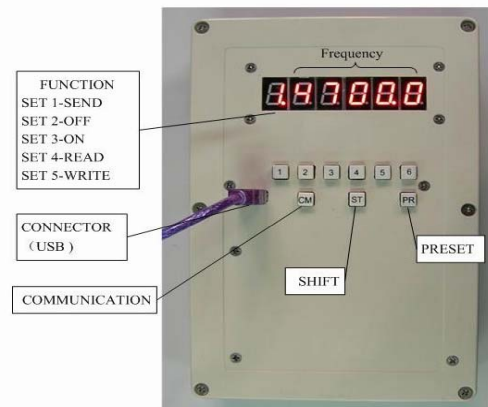



Appendix B USART CONTROL PROTOCOL Version: 3.1 (Re: 20080701)

Communication port programming

This component adopts standard USART mode, the communication protocol is as follows:

- Baud rate is 9600 bits/s,
- Transferring data is one byte (i.e., 8 bits) without Even-Parity,
- One stop bit is appended.

Examples programming steps.

Example 1

Send data of frequency 4786.5 MHz to this component, do as the steps listed below:

Convert the frequency data to the type of format that can be accepted by the up-converter (i.e., the data should be in the form of "0XYYYYOY").

X represents command code, taking the value of 1,2,3 ,4,5or 6 (Note, functions of the command code are:

- 1-change and save the frequency to EPROM
- 2-turn off the power of the PA parts,
- 3-turn on the power of the PA parts,
- 4-reading the frequency on which the component is working,
- 5-change the frequency only without saving to EPROM,
- 6-reset the module to the factory initialized frequency).

Y is the BCD code corresponding to the decimal frequency data.

The two zeros in the following format are fixed and can **NOT** be changed

To set up the output frequency as 4786.5MHz, the data send to the module will need to be converted to 01478605.

2. Set the host sending data as below:

Communication mode: asynchrones full duplex mode. (USART)
Communication protocol: 8 bits of data with one stopping bit, without Even-Parity code. Baud rate is 9600 Baud/s.
Communication period protocol: 5ms one frame, 2 bytes for TX, 1 byte for receiving data.

Handshakes of the communication: Host transmits calling code **99H+AAH** first (H indicates the code is hexadecimal), waiting for response **BBH** from the component.

Host sends the information of length, command, data and the ending code after receiving the response code BBH.
The module should then send a response code **CCH** to the host when it correctly receives a byte information from the host.
CCH code Indicates that the host is successful sending a data frame . Transmitting data begins with the lowest bit.

If the host can not receive the handshakes response codes **CCH** from module, the host needs to wait for 2 seconds then resend the handshakes and instructions again.

3. Communication process for the converted data such as 01478605:

The host transmits calling code "**99H+AAH**" first, waiting for response code from the component.
If the response code is "**BBH**", the component is in the ready state to receive data.
Then host will send first frame data "**05H+86H**" and wait for module response.
If module response by "**CCH**" to host, it means the module received the data frame correctly.
After host receive CCH from module, the host will send 2nd data frame "**47H+01H**", then wait again for **CCH** from module.
Once receive **CCH** from module, all transmit is finished.

If time between BB and next frame more than 100ms (recommnd 20-60ms), hand shake command 99H+AAHneed to be resend after one minute in order to communicate with the unit



Appendix B USART CONTROL PROTOCOL - Continue

4. Communication process for the command code X (2, 3, 4 or 6) :

Convert the command code **X** to the type that can be accepted by this component (i.e. 0XYYYYYY, under command code, X stand for 2,3,4 or 6, Y can be any number.).

The host transmits calling code "**99H+AAH**" first, waiting for response code from the component.

If the response code from module is "**BBH**", the module is in the ready state to receive data.

Host send first frame data "**YYH+YYH**" (YYH can be any number) and wait for confirmation **CCH** from module.

Once the host receive **CCH** from module, host will send 2nd frame "**YYH+0XH**"

When host receive CCH from module again, it indicate the communication is finished successfully.

Communication protocol between the control port and the module

Baud rate:9600 bit/s

The data consist of one start bit, one stop bit and 8 data bits without Even-Parity.

1) change frequency command 1 or 5

For example: set output frequency to 4786.5MHz.

- Change to the module recognized frame format 01H+47H+86H+05H
- Host send handshaking code 99H+AAH
- Module response by BBH
- Host send first frame data 05H+86H
- Module response by CCH
- Host then send 2nd frame data 47H+01H
- Module response by CCH again,
- End.

2) turn off the power, turn on the power, reset to factory setting frequency. (2, 3, 6)

For example: Turn off PA power: 02H+YYH+YYH+YYH

- The host send 99H+ AAH
- The module response by BBH
- The host sending first frame data YYH+YYH (Y can be any data)
- The component responding with CCH
- The host send 2nd frame YYH+02H (again Y can be any data)
- Module response by CCH again.
- End.

3) Read frequency setting from module (command code 4)

For example: 04H+YYH+YYH+YYH

- The host send 99H+ AAH
- The module response by BBH
- The host sending first frame data YYH+YYH (Y can be any data)
- The component responding with CCH
- The host send 2nd frame YYH+04H (again Y can be any data)
- Module response by CCH again.
- Module send another 3 bytes frequency data back to host "05H+65H+47H"
(Assume frequency in the module is 4765.5MHz)