

SF2141B

**210.38 MHz
SAW Filter**

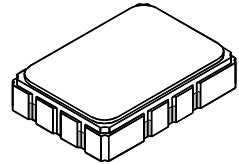

SMP-03

- Precision SAW Filter
- Simple Matching to 50 ohms
- 5.0 x 7.0 mm Surface-mount Case
- Complies with Directive 2002/95/EC (RoHS)



Absolute Maximum Ratings

Rating	Value	Units
Input Power Level	+10	dBm
DC Voltage on any Non-ground Terminal	3	V
Storage Temperature Range in Tape and Reel	-40 to +85	°C
Maximum Soldering Temperature	265 °C for 10 s	

Electrical Characteristics

Characteristic	Sym	Notes	Min	Typ	Max	Units
Center Frequency	f_C	1	210.38			MHz
Insertion Loss at f_C	IL	1		8.2	11	dB
Amplitude Ripple, $f_C \pm 0.30$ MHz	AR	1		0.4	1.3	dB _{P-P}
Group Delay				716		ns
Group Delay Ripple, $f_C \pm 0.30$ MHz				150		ns _{P-P}
Phase Linearity, $f_C \pm 0.63$ MHz	RMS			2.60	3.75	deg
5 dB Bandwidth			± 0.63	± 0.82		MHz
34 dB Bandwidth				± 1.18	± 1.25	
36 dB Bandwidth				± 1.20	± 1.55	
Attenuation Referenced to IL:						
$f_C \pm 1.25$ MHz			35	48		dB
140 to 206 MHz			38	45		
214.76 to 280.00 MHz			38	48		
Operating Temperature Range	T_A	1	-25		+85	°C
Case Style		5	SMP-03 7 x 5 mm Nominal Footprint			
Lid Symbolization, YY=year, WW=week, S=shift			RFM SF2141B YYWWS##			



CAUTION: Electrostatic Sensitive Device. Observe precautions for handling.

NOTES:

1. Unless noted otherwise, all specifications apply over the operating temperature range with filter soldered to the specified demonstration board with impedance matching to 50 Ω and measured with 50 Ω network analyzer.
2. Unless noted otherwise, all frequency specifications are referenced to the nominal center frequency, f_C .
3. Rejection is measured as attenuation below the minimum IL point in the passband. Rejection in final user application is dependent on PCB layout and external impedance matching design. See Application Note No. 42 for details.
4. The design, manufacturing process, and specifications of this filter are subject to change.
5. Tape and Reel Standard Per ANSI / EIA 481.
6. Either Port 1 or Port 2 may be used for either input or output in the design. However, impedances and impedance matching may vary between Port 1 and Port 2, so that the filter must always be installed in one direction per the circuit design.
7. US and international patents may apply.
8. Murata, stylized Murata logo, and Murata N.A., Inc. are registered trademarks of Murata Manufacturing Co., Ltd.

Single-ended 50 ohm input / output test circuit

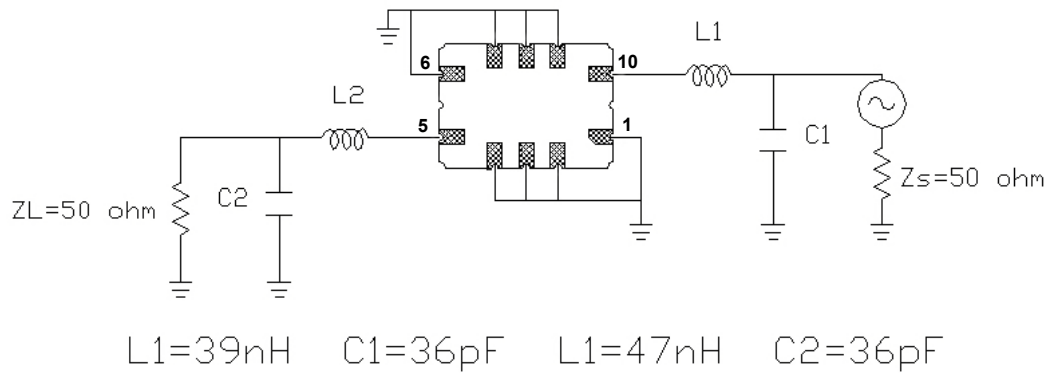

Single-ended 50 ohm input / 500 ohm balanced output test circuit

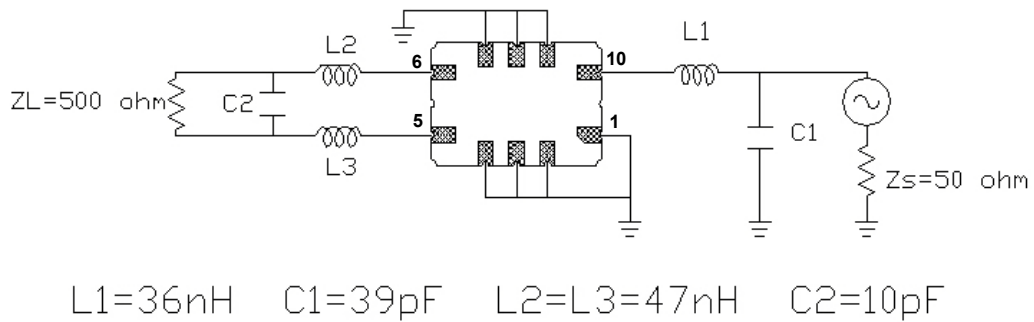

Filter Broadband Amplitude Response

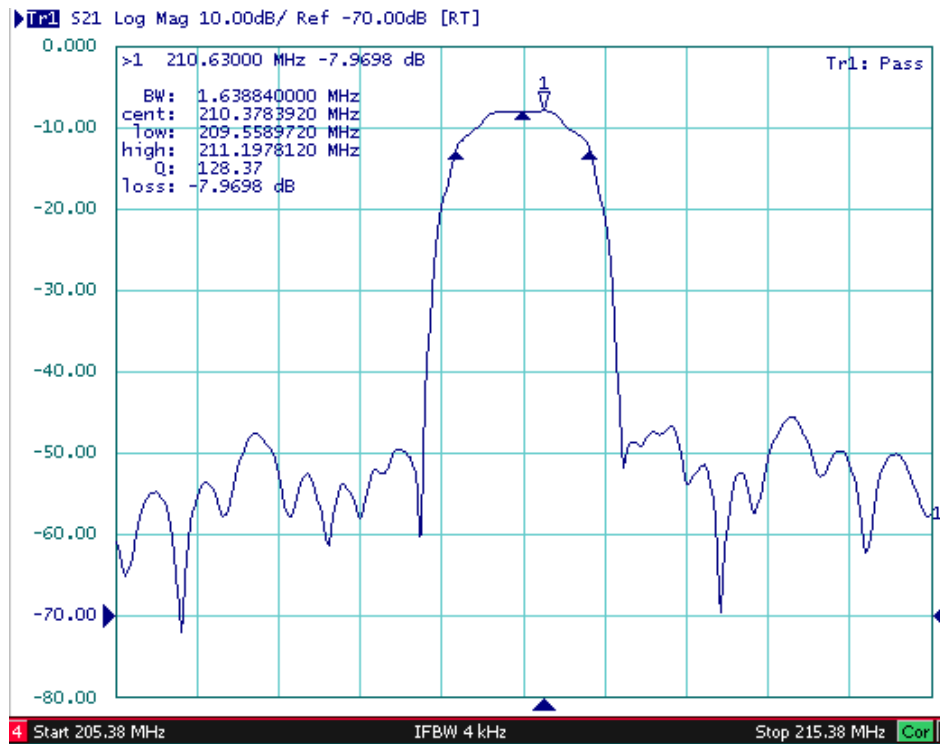

Filter Passband Amplitude Response

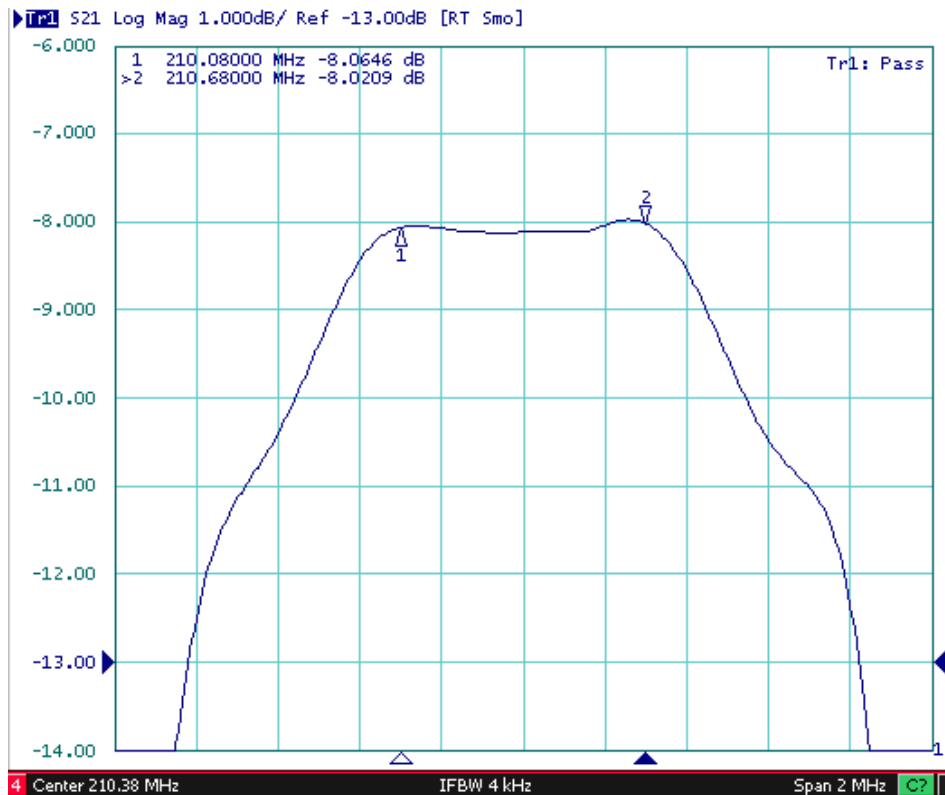

Filter Passband Group Delay

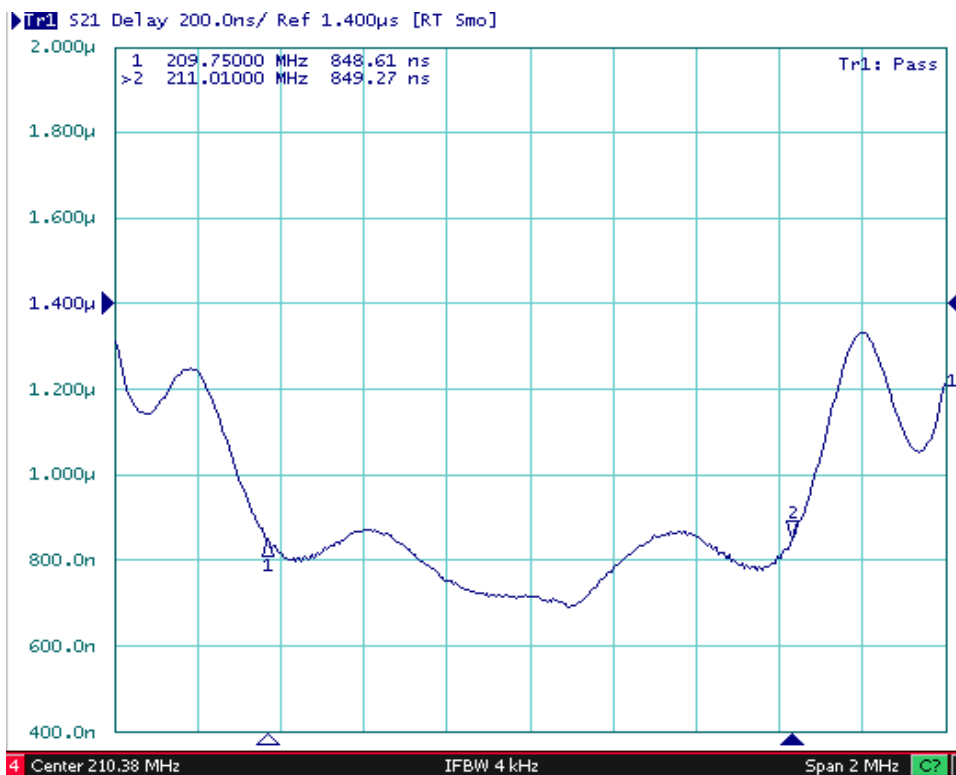

SMP-03 Case

10-Terminal Ceramic Surface-mount Case

7 x 5 mm Nominal Footprint

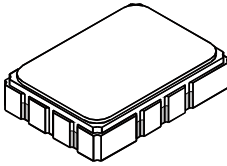

Recommended PCB Footprint

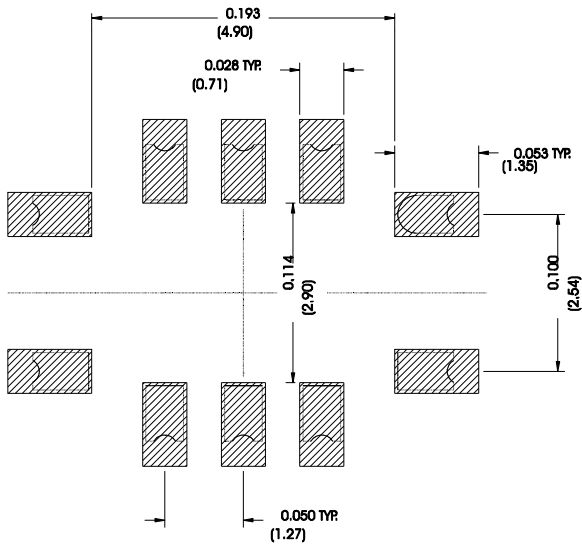

Case Dimensions						
Dimension	mm			Inches		
	Min	Nom	Max	Min	Nom	Max
A	6.80	7.00	7.20	0.268	0.276	0.283
B	4.80	5.00	5.20	0.189	0.197	0.205
C		1.65	2.00		0.065	0.079
D	.47	0.60	.73	0.019	0.024	0.029
E	2.41	2.54	2.67	0.095	0.100	0.105
H	0.87	1.0	1.13	0.034	0.039	0.044
J	4.87	5.00	5.13	0.192	0.197	0.202
K	2.87	3.00	3.13	0.113	0.118	0.123
P	1.14	1.27	1.40	0.045	0.050	0.055

Electrical Connections	
Connection	Terminals
Input	1
Input Ground	10
Output	6
Output Ground	5
Ground	All others

Case	
Materials	
Solder Pad Plating	0.3 to 1.0 μm Gold over 1.27 to 8.89 μm Nickel
Lid Plating	2.0 to 3.0 μm Nickel
Body	Al_2O_3 Ceramic
Pb Free	

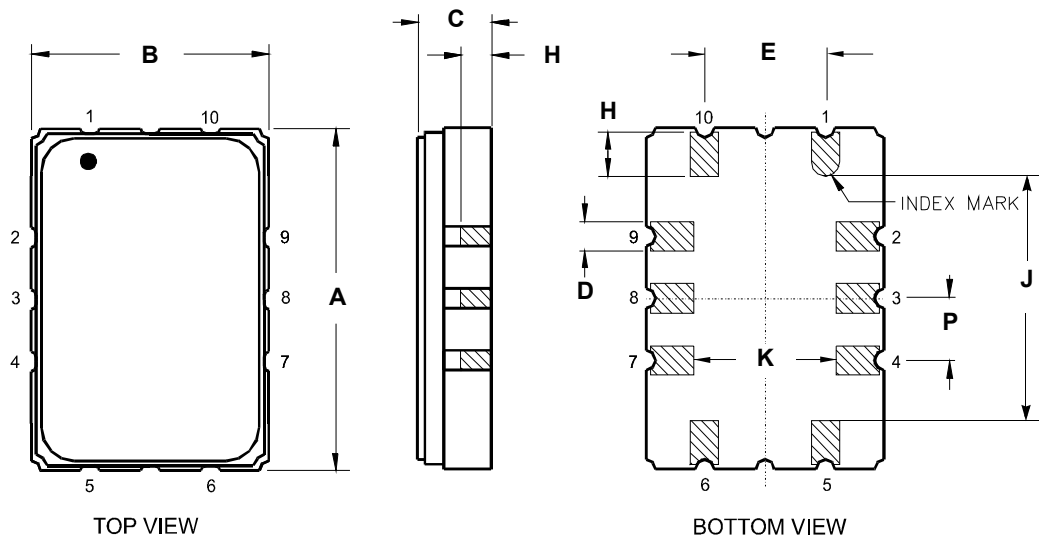

Tape and Reel Specifications

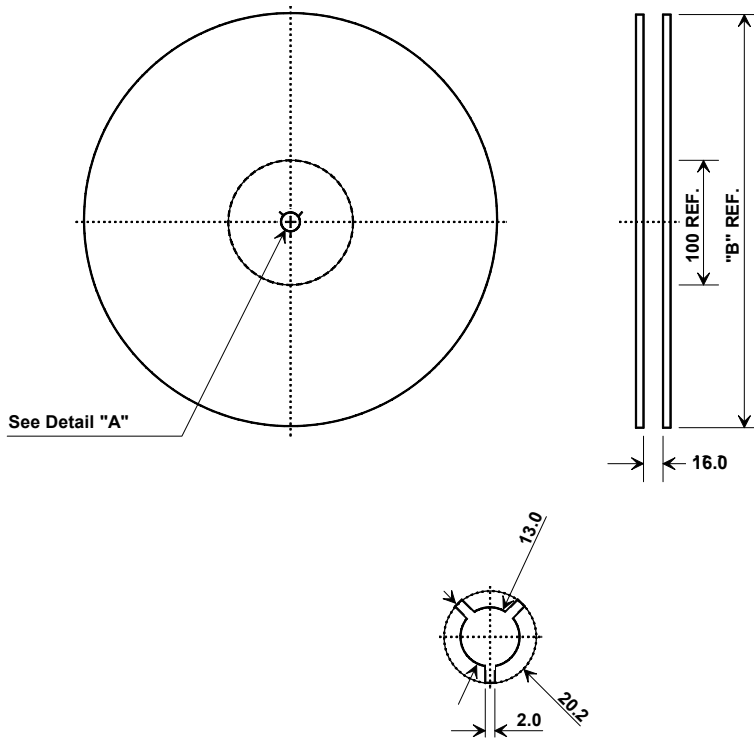

"B"		Quantity Per Reel
Inches	millimeters	
7	178	500
13	330	2000

COMPONENT ORIENTATION and DIMENSIONS

Carrier Tape Dimensions	
Ao	5.5 mm
Bo	7.5 mm
Ko	2.0 mm
Pitch	8.0 mm
W	16.0 mm

