

Features:

- Octave bandwidth, specification from 100~500MHz
- Low noise figure, high gain with good gain flatness
- Low VSWR, unconditional stable
- Small size, low cost
- SMA female connector I/O
- Single DC power supply, internal voltage regulator, operating voltage from +10~+15V
- Operating temperature -40~+75°C, storage temperature -55~+125°C



Electrical Specifications

Parameters	Minimum	Typical	Maximum
Frequency Range	100 MHz		500MHz
Noise Figure (from 50MHz)		0.6 dB	0.8 dB
P-1dB Compression Point	+16dBm	+17 dBm	
Nominal SS Gain @25°C	19 dB	20dB	23 dB
Gain flatness		+/-0.5 dB	+/-0.75 dB
Gain Variation		+/-1.0 dB	
Input VSWR		1.3:1	1.5:1
Output VSWR		1.3:1	1.6:1
Reverse Isolation	24 dB	27dB	
Spurious			-60 dBc
Operating Temperature	-40°C		+75°C
Survival Temperature	-55°C		+125°C
DC Voltage	+9V	+12 V	+15 V
DC Supply Current	50 mA	60 mA	70 mA
In/Out connectors	SMA female		
Size	1.5"x0.85"x0.375		

Functional Diagram

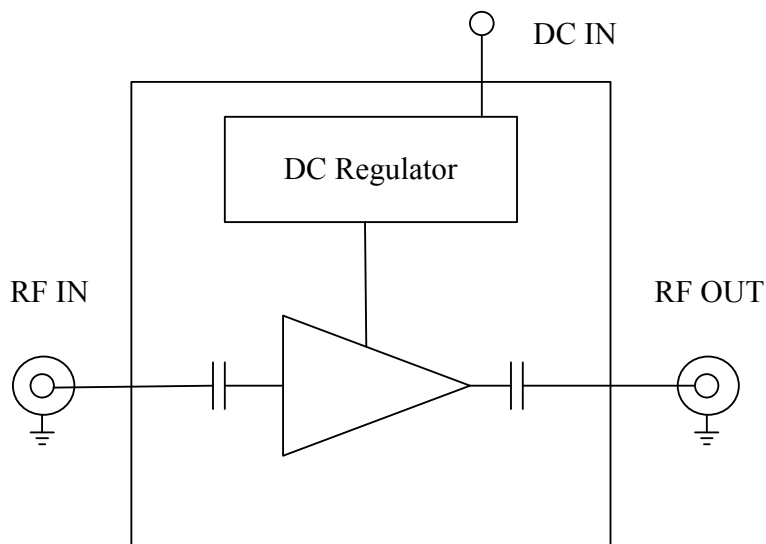

Mechanical Structure:

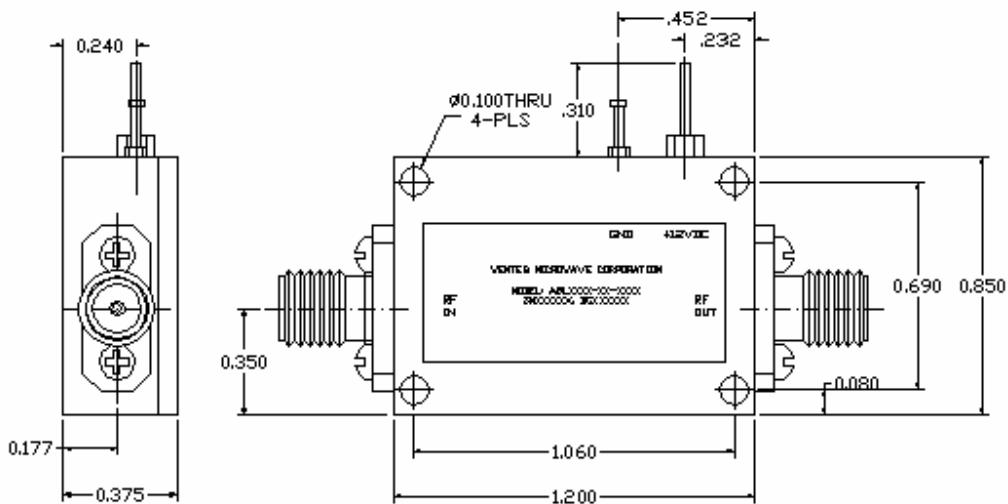

Note: All units in inches.

Typical Test Results:

ABL0050-20-2008 Measured Gain and Return Loss vs Frequency

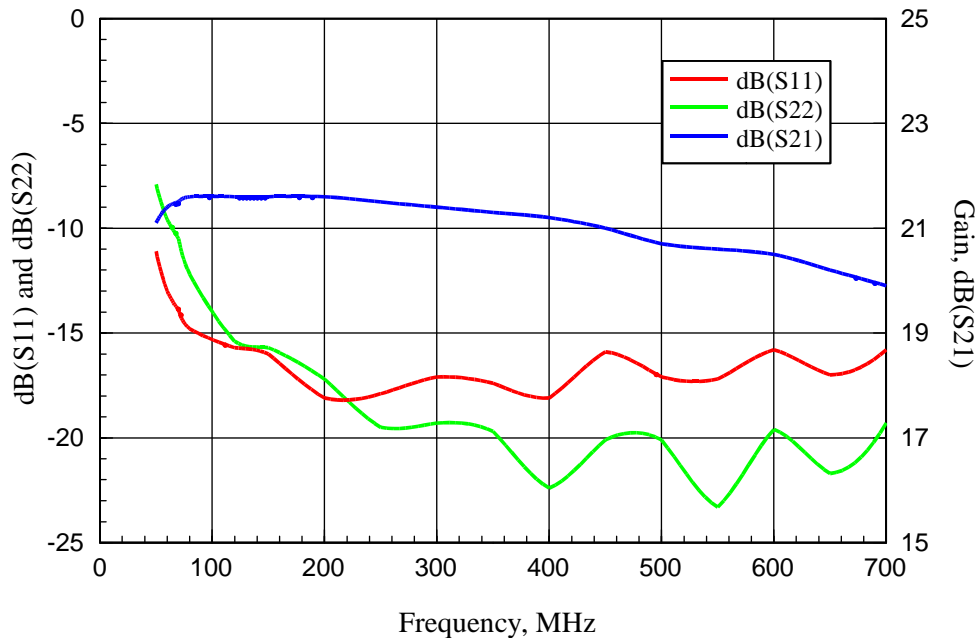

ABL0050-20-2008 Measured Noise Figure vs Frequency

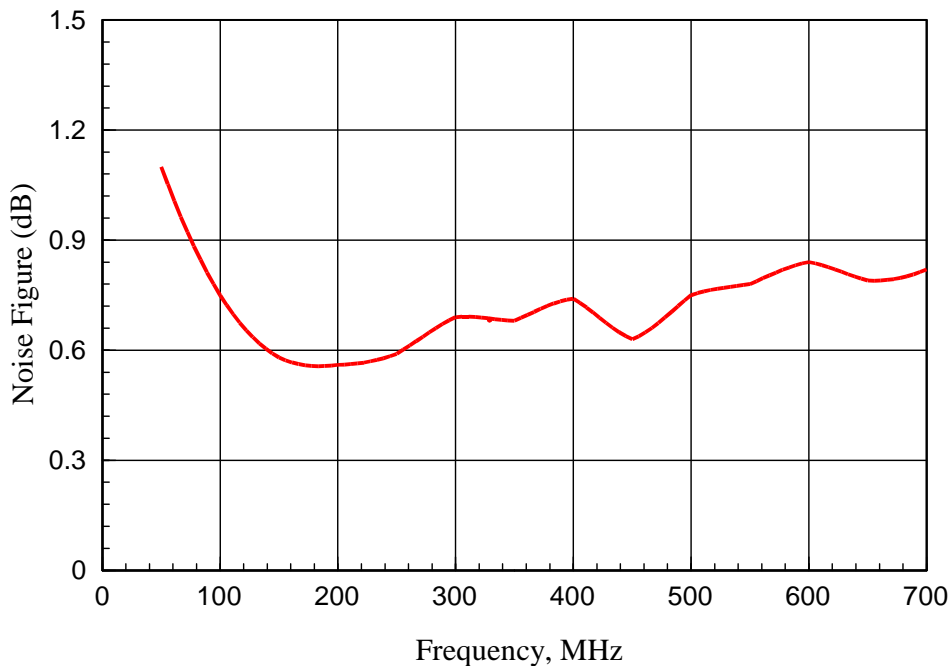

ABL0050-20-2008 Measured Gain and Output Power vs Input Power
Test Frequency: 100MHz

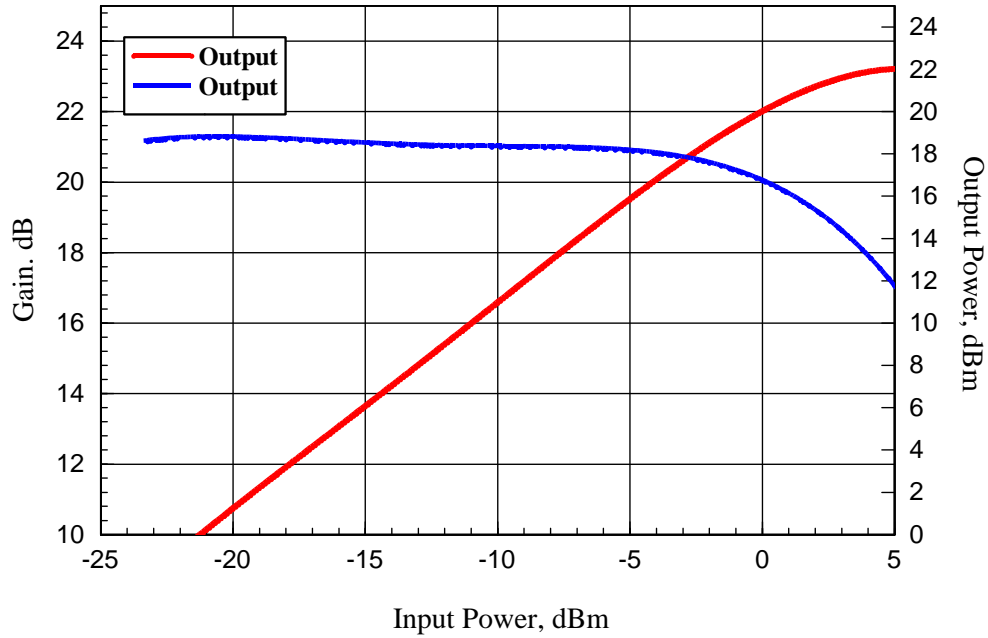

ABL0050-20-2008 Measured Gain and Output Power vs Input Power
Test Frequency: 300MHz

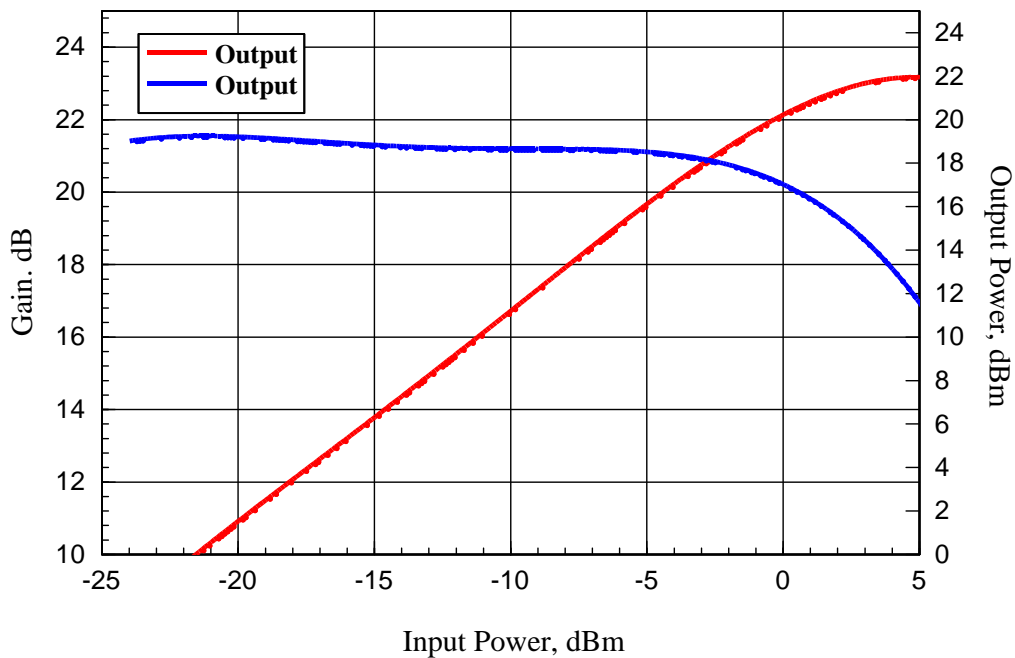

ABL0050-20-2008 Measured Gain and Output Power vs Input Power
Test Frequency: 500MHz

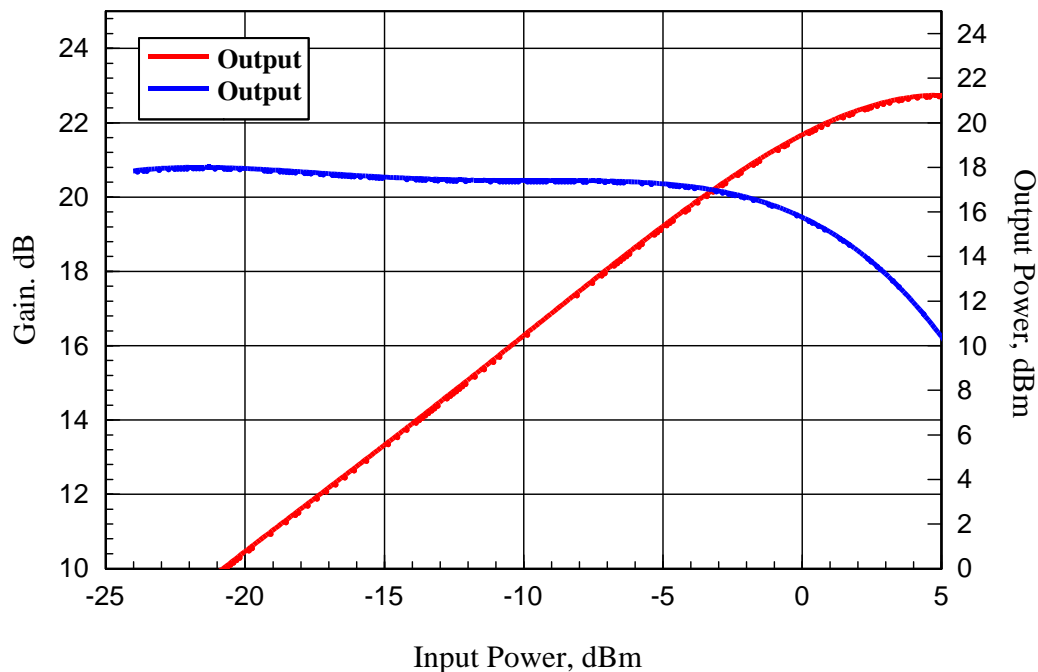

Absolute Maximum Ratings

DC Voltage	+15V
RF Input Power	+10dBm
Storage Temperature	-55~+125°C
Operating Temperature	-40~+75°C