



When precision matters...™

TW3030 Permanent Mount GPS L1 Antenna

The TW3030 by Tallysman Wireless is a professional grade, permanent mount GPS L1 antenna, specially designed for professional precision timing applications.

The TW3030 features a custom high performance, wide band patch element, a 30dB gain LNA stage and a high rejection out-of-band SAW filter. It provides ± 10 MHz bandwidth centred on 1575.42 MHz and covers the GPS L1, Galileo E1 and SBAS (WAAS/EGNOS/MSAS) signals. It provides great axial ratio, excellent circular polarized signal reception, great multipath rejection and great out-of-band signal rejection.

The TW3030 is housed in a compact, industrial-grade weather-proof, domed shaped enclosure. Its radome is available in dark gray or white, and two options for pole mounting are available an L-bracket (P/N#23-0040-0) or a pipe mount (P/N#23-0065-0)



TW3030 Dimensions (mm)

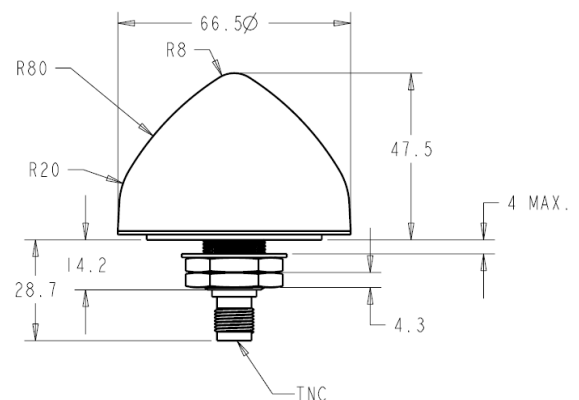

Applications

- High Accuracy, Mission Critical GPS Timing
- Military & Security
- Network Timing and Synchronisation

Features

- Great axial ratio
- Low noise LNA: 1 dB
- High rejection SAW filter
- High gain: 30 dB typ.
- Low current: 10 mA typ.
- ESD circuit protection: 15 KV
- Wide voltage input range: +2.5 to 16 VDC
- Weather proof housing: IP67

Benefits

- Excellent multipath rejection
- Increase system accuracy
- Excellent signal to noise ratio
- Great out of band signal rejection
- Ideal for harsh environments
- RoHS compliant



When precision matters...™

TW3030 Permanent Mount GPS L1 Antenna

Specifications V_{cc} = 3V, over full bandwidth, T=25°C

Antenna

Antenna Element Gain (100mm ground plane)	4 dBiC at 90°
Axial Ratio (over full bandwidth)	4 dB at 90°

Electrical

Architecture	2 stage LNA circuit + a mid section SAW filter. (Pre-filter option available)
Frequency Bandwidth	1575 MHz ± 10 MHz
Polarization	RHCP
Gain	30 dB typ. (at 1575.42 MHz)
Out-of-Band Rejection	<1560 MHz >30 dB >1600 MHz >30 dB >1620 MHz >45 dB
VSWR (at LNA input)	<1.5:1
Noise Figure	1 dB typ.
Supply Voltage Range	+2.5 to 16 VDC nominal (12VDC recommended maximum)
Supply Current	10 mA typ.
ESD Circuit Protection	15 KV air discharge

Mechanicals & Environmental

Mechanical Size	66.5 mm dia. x 45 mm H
Operating Temp. Range	-40 to +85 °C
Enclosure	Radome: Dark Gray or White ASA Plastic, Base: Zamak White Metal
Weight	150 g
Environmental	IP67 and RoHS compliant
Shock	Vertical axis: 50 G, other axes: 30 G
Vibration	3 axis, sweep = 15 min, 10 to 200 Hz sweep: 3 G
Warranty	One year – parts and labour

Ordering Information

Legacy Part Number:	TW3030 – GPS L1 antenna, 32-3030-xx-yy		
Connector:	xx = 00 TNC	xx = 01 N Type (premium applies)	
Radome Colour	yy = 00 Dark grey conical	yy = 01 White conical	

* As a result of a growing product portfolio, Tallysman has rationalized its part number system. No changes have been made to the mechanical or electrical properties of these products. Where administratively possible, please use the following Part Numbers.

TW3010 – GPS L1 antenna 33-3010-xx-yy-zzzz

Where xx = connector type, yy = type and colour of radome, and zzzz = cable length in mm (where applicable)

Please refer to the Ordering Guide (<http://www.tallysman.com/orderingguide.php>) for the current and complete list of available radomes and connectors.

Tallysman Wireless Inc

106 Schneider Road, Unit 3
Ottawa ON K2K 1Y2 Canada Tel 613 591 3131 Fax 613 591 3121
sales@tallysman.com

The information provided herein is intended as a guide only and is subject to change without notice. This document is not to be regarded as a guarantee of performance. Tallysman Wireless Inc. hereby disclaims any or all warranties and liabilities of any kind.
© 2010 Tallysman Wireless Inc. All rights reserved. Rev 2.2