

# WAVEGUIDE WR28 DUAL DIRECTIONAL COUPLER -RWGDCP28SB

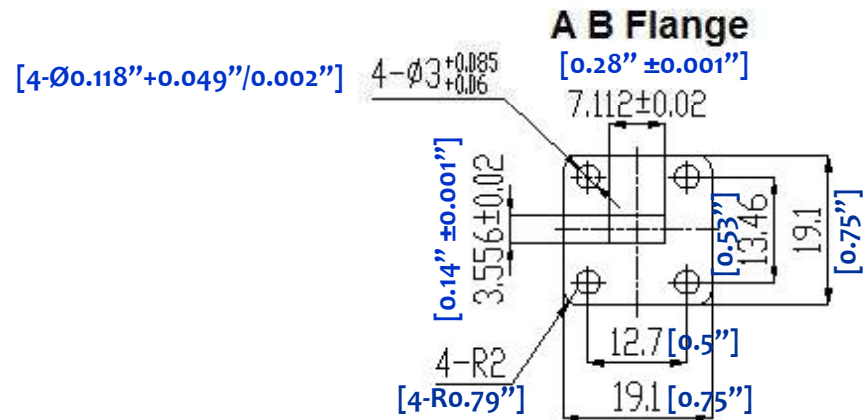
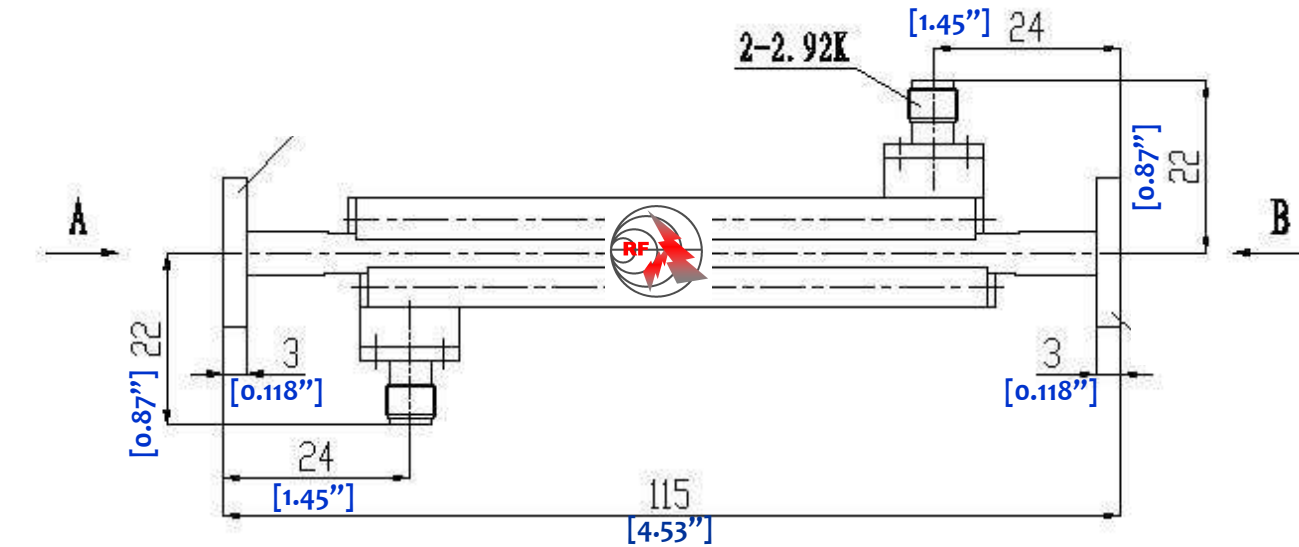

3.0 Electrical Specifications		
3.1	Frequency Range	26.5-40GHz
3.2	Coupling	40dB
3.3	Directivity	20dB min
3.4	VSWR	1.1
3.5	Insertion Loss	0.3dB max.
3.6	Average Power	50W

1.0 Mechanical Specifications		
1.1	Waveguide type	Rectangular WR28
1.2	Flange type	CPRG, CPRF, COVER, CHOKE available
1.3	Flange Holes	Through
1.4	Basis-material	Alloyed Cuprum
1.5	Internal Body Finish	Plated chromate or conversion
1.6	External Body Finish	Body painted with gray/black epoxy enamel

2.0 Environment specifications		
2.1	Operation Temp.	-40°C~+85°C
2.2	Storage Temp.	-60°C~+125°C
2.3	Altitude	45000 ft
2.4	Vibration	10g rms (15 degree 2KHz)
2.5	Humidity	100% RH at 35c, 95%RH at 40 deg c
2.6	Shock	20G for 11msc

PAGE	OF	DATE
		Jul 9 <sup>th</sup> 2008
<small>PROPRIETARY INFORMATION THE INFORMATION CONTAINED IN THIS DOCUMENT IS THE PROPERTY OF RF-LAMBDA EXCEPT AS SPECIFICALLY AUTHORIZED IN WRITINGS BY RF-LAMBDA. THE HOLDER OF THIS DOCUMENT SHALL KEEP ALL INFORMATION CONTAINED HEREIN CONFIDENTIAL AND SHALL PROTECT SAME IN THE WHOLE OR IN PART FROM DISCLOSURE AND DISSEMINATION OF ALL THIRD PARTIES AND SHALL USE SAME FOR OPERATING AND MAINTENANCE PURPOSES ONLY</small>		DESIGN
		RFPC
		RF-LAMBDA
		RFPC
		CAD MODEL REVISION
		1-4
		ASSEMBLY REVISION
		VS20-3
		ASSEMBLY NAME
		RFLVR04
		DRAWING NUMBER
		D02-5
<a href="http://www.rflambda.com">www.rflambda.com</a>		
<b>RF-LAMBDA</b>		SIZE LT
		SHEETS 1 OF 1