

MINIATURE HIGH FREQUENCY PRECISION LOW PHASE NOISE OCXO MV218

Features:

- Small package size of 25x25x10.3 mm
- Low Phase Noise – floor of <-167 dBc/Hz
- Wide temperature range
- Very short warm-up time – less than 60 seconds

Frequency range: 48.0-1200.0 MHz

Standard Frequency: 50.0; 84.0;
98.304; 100.0; 120.0; 160.0 MHz

Power Supply

5 V

12 V

Package type (max)

25.8x25.8x10.3 mm A10

25.8x25.8x12.7 mm N
(with SMA connector)

ORDERING GUIDE: MV218-B 300 J-12V-3-100.0 MHz-A10

Availability of certain stability vs. operating temperature range	Stability vs. temperature range				
	$\pm 5 \times 10^{-7}$	$\pm 3 \times 10^{-7}$	$\pm 1 \times 10^{-7}$	$\pm 7.5 \times 10^{-8}$	$\pm 5 \times 10^{-8}$
	500	300	100	75	50
A 0...+55 °C	A	A	A	A	A
B -10...+60 °C	A	A	A	A	C
C -20...+70 °C	A	A	A	C	NA
D -40...+70 °C	A	A	C	C	NA
EX -40...+85 °C	A	C	C	NA	NA

A – available, NA – not available, C – consult factory

For other temperature ranges see designation at the end of Data Sheet.

Aging

Aging	Rate
L	$\pm 1.5 \times 10^{-6}$ /year
K	$\pm 1 \times 10^{-6}$ /year
J	$\pm 5 \times 10^{-7}$ /year
I	$\pm 3 \times 10^{-7}$ /year
H	$\pm 2 \times 10^{-7}$ /year
G	$\pm 1 \times 10^{-7}$ /year

Phase noise, dBc/Hz

(for 100.0 & 500.0 MHz, for power supply 12V)

Option	1	2	3	4
Frequency	100	500	100	500
10 Hz	-85	-70	-90	-75
100 Hz	-115	-100	-120	-105
1000 Hz	-140	-125	-145	-130
10000 Hz	-160	-140	-162	-142
100000 Hz	-160	-140	-162	-142

Phase noise, dBc/Hz

(for 100.0 & 500.0 MHz, for power supply 5V)

Option	1	2	3	4
Frequency	100	500	100	500
10 Hz	-85	-70	-90	-75
100 Hz	-115	-100	-120	-105
1000 Hz	-140	-125	-145	-130
10000 Hz	-152	-140	-155	-140
100000 Hz	-160	-140	-160	-140

Package drawings:

A10

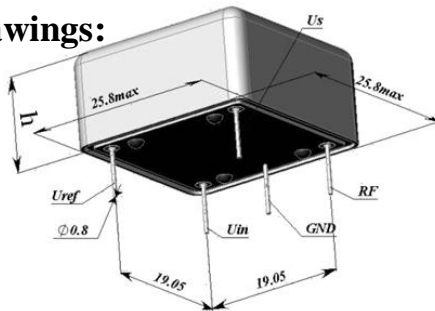

N:

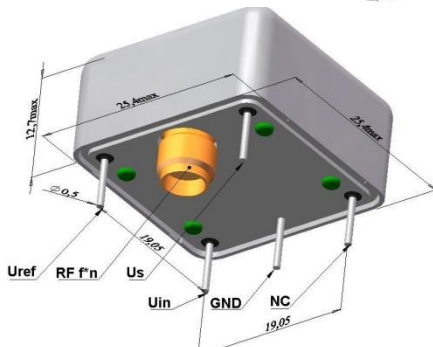

Frequency stability vs. load changes	$< \pm 2 \times 10^{-8}$
Frequency stability vs. power supply changes	$< \pm 1 \times 10^{-7}$
Warm-up time within accuracy of $< \pm 2 \times 10^{-7}$ @ 25°C	<60 sec.
Power supply (Us)	12V \pm 10% 5V \pm 10%
Steady state current consumption @ 25°C	< 115 mA <250 mA
Peak current consumption during warm-up @ 25°C	< 370 mA < 800 mA
Reference voltage output (Uref)	+10V +4V
with external control voltage range (Uin)	0...+10 V 0...+4V
Frequency pulling range	$> \pm 3 \times 10^{-6}$

Output	SIN
Level	>400 mV RMS
Load	50 Ohm \pm 10%
Harmonics	<-25 dBc
Vibrations	10-500 Hz, 5g
Storage temperature range	-55...+70 °C

Additional notes:

- For non standard operating temperature ranges please use the following two letters designations (first letter for the lower limit, second letter for the upper limit), °C:

A	B	C	D	E	F	G	H	J	K	L	M	N	P	Q	R	S	T	U	W	X
-60	-55	-50	-45	-40	-30	-20	-10	0	+10	+30	+40	+45	+50	+55	+60	+65	+70	+75	+80	+85