



O-8000AT Series



1. Specification		
Frequency range:	10 ... 100 MHz	
Type:	O-8500AT	O-8300AT
Supply voltage V_S :	+5.0 V \pm 5 %	+3.3 V \pm 5 %
Frequency stability vs. temperature options:		
$\leq \pm 3 \times 10^{-8}$ vs. 0 °C to +50 °C:	850x	830x
$\leq \pm 5 \times 10^{-8}$ vs. -10 °C to +60 °C:	851x	831x
$\leq \pm 1 \times 10^{-7}$ vs. 0 °C to +70 °C:	852x	832x
$\leq \pm 1 \times 10^{-7}$ vs. -20 °C to +70 °C:	853x	833x
$\leq \pm 2 \times 10^{-7}$ vs. -40 °C to +85 °C:	854x	834x
Long term stability (aging) options (after 30 days of continuous operation)		
$\leq \pm 1 \times 10^{-8}$ / day; $\leq \pm 5 \times 10^{-7}$ / year:	85x1	83x1
$\leq \pm 5 \times 10^{-9}$ / day; $\leq \pm 3 \times 10^{-7}$ / year:	85x2	83x2
Frequency stability vs. supply voltage changes $V_S \pm 5$ %: vs. load changes ± 5 %:	$\leq \pm 1.0 \times 10^{-8}$ $\leq \pm 5.0 \times 10^{-9}$	
Frequency control by external tuning voltage :	$\geq \pm 4$ ppm	
Tuning voltage range:	+0.5 V to +4.5 V	+0.3 V to 3.0 V
Transfer function / Linearity:	Positive / ≤ 10 %	
Power consumption steady state @ +25 °C: during warm-up:	≤ 1.0 W ≤ 3.0 W	
Warm-up time: (for a typical accuracy of $< \pm 1 \times 10^{-7}$ @ +25 °C referred to final frequency after 1 hour)	≤ 5 min	
Output voltage / load Option H: Option S:	(LV)HCMOS / 1 kOhm // 15 pF Sinewave / $> +3$ dBm / 50 Ohm	
Phase noise (typical for 10 MHz): 10 Hz: 100 Hz: 1 kHz: 10 kHz:	≤ -90 dBc / Hz ≤ -125 dBc / Hz ≤ -140 dBc / Hz ≤ -150 dBc / Hz	
Storage temperature range:	-45 °C to +90 °C	

4				KVG Quartz Crystal Technology GmbH
3				P.O. Box 61
2				D-74924 Neckarbischofsheim
1		21.06.07	Rudolph	Tel. +49 (0) 7263 / 648-0
ED	Description	Date	Name	Fax. +49 (0) 7263 / 6196



ROHS-Compliant Product

O-8000AT Series



2. Environmental conditions

According to KVG Product Qualification Procedure AA-QM-200

3. Marking

Manufacturer's name, date code (week/year), Specification; Center frequency

4. Case

BF169-8.5-SMD

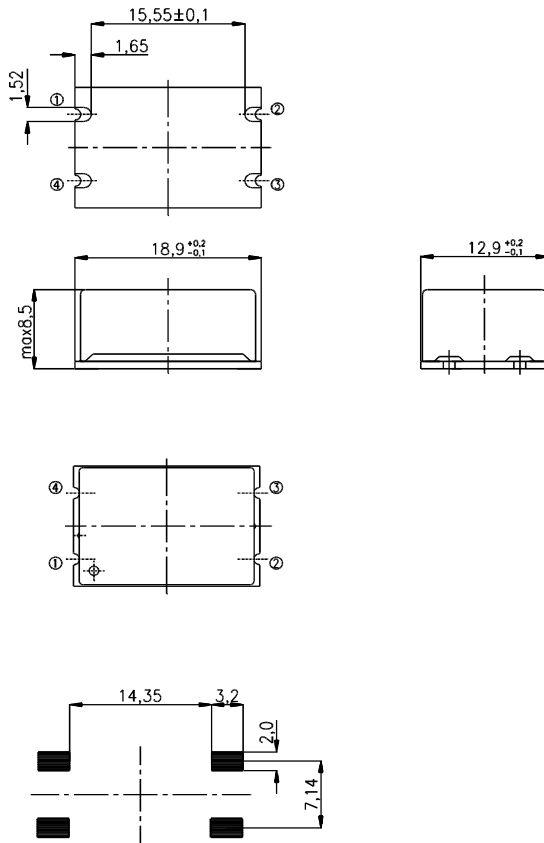

SMD-Lötflächen (Anwender)

1.Pin configuration

1. Control voltage V_C
2. Ground, case
3. RF-output
4. Supply voltage V_S

4				KVG Quartz Crystal Technology GmbH
3				P.O. Box 61
2				D-74924 Neckarbischofsheim
1		21.06.07	Rudolph	Tel. +49 (0) 7263 / 648-0
ED	Description	Date	Name	Fax. +49 (0) 7263 / 6196



O-8000AT Series



5. Recommended soldering profile

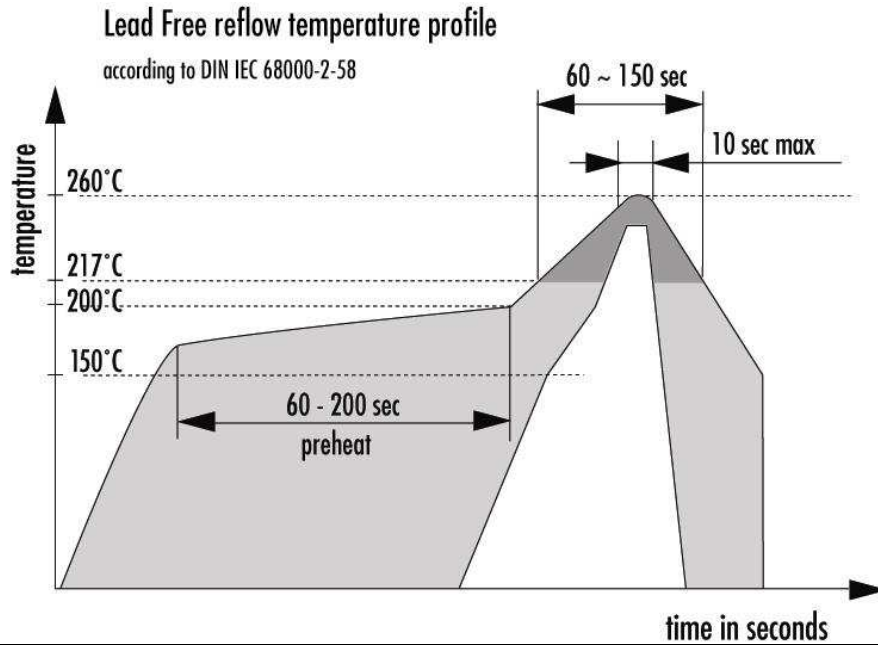

6. Tape and reel

Drawing to be amended

4				KVG Quartz Crystal Technology GmbH
3				P.O. Box 61
2				D-74924 Neckarbischofsheim
1		21.06.07	Rudolph	Tel. +49 (0) 7263 / 648-0
ED	Description	Date	Name	Fax. +49 (0) 7263 / 6196