

ASW126 Data Sheet

3.3 V Gain Block Amplifier MMIC over DC~3500 MHz

1. Product Overview

1.1 General Description

ASW126, 3.3 V internally matched gain block amplifier MMIC, has excellent input and output return loss, and high linearity over a wide range of frequency DC~3500 MHz, being suitable for use in both receiver and transmitter of telecommunication systems up to 3.5 GHz. The amplifier is available in a SOT363 package and passes through the stringent 100% DC & RF test via an automated test handler.



1.2 Features

- 20.1 dB Gain at 900 MHz
- 17 dBm P1dB at 900 MHz
- 31 dBm Output IP3 at 900 MHz
- 3.7 dB NF at 900 MHz
- MTTF > 100 Years
- Minimum External Matching Components
- Single Supply: +3.3 V

1.3 Applications

- Base Station Infrastructure
- Repeater
- Telecommunication System

1.4 Package Profile & RoHS Compliance

 <p>SOT363, 2.1x2.0 mm², surface mount</p>	 <p>RoHS-compliant</p>
--	---

2. Summary on Product Performances

2.1 Typical Performance

Supply voltage = +3.3 V, T_A = +25 °C, Z_O = 50 Ω.

Parameter	Typical								Unit
Frequency	150	500	900	1750	2000	2400	2700	3500	MHz
Gain	24.7	22.6	20.1	15.5	14.4	12.9	11.8	9.6	dB
S11	-22	-16	-20	-20	-19	-16	-14	-13	dB
S22	-11	-10	-11	-11	-12	-13	-15	-14	dB
Noise Figure	3.6	3.8	3.7	3.8	3.9	4.1	4.2	4.3	dB
Output IP3 ¹⁾	28.0	30.0	31.0	32.0	33.5	33.5	33.0	33.5	dBm
Output P1dB	16.0	16.5	17.0	17.0	17.5	17.5	18.0	17.5	dBm
Current	37								mA
Device Voltage	+3.3								V

1) OIP3 is measured with two tones at the output power of +0 dBm/tone separated by 1 MHz.

2.2 Product Specification

Supply voltage = +3.3 V, T_A = +25 °C, Z_O = 50 Ω.

Parameter	Min	Typ	Max	Unit
Frequency		900		MHz
Gain	19.1	20.1		dB
S11	-17	-20		dB
S22	-9	-11		dB
Noise Figure		3.7	4.0	dB
Output IP3	29	31		dBm
Output P1dB	16	17		dBm
Current	30	37	44	mA
Device Voltage		+3.3		V

2.3 Pin Configuration

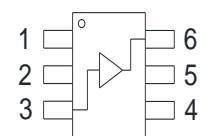
Pin	Description	Simplified Outline
1, 2, 4, 5	Ground	
3	RF_IN	
6	RF_OUT & Bias	

2.4 Absolute Maximum Ratings

Parameters	Max. Ratings
Operation Case Temperature	-40 to +85 °C
Storage Temperature	-40 to +150 °C
Device Voltage	+4 V
Operation Junction Temperature	+150 °C
Input RF Power (CW, 50 Ω matched)	+24 dBm

2.5 Thermal Resistance

Symbol	Description	Typ	Unit
R _{th}	Thermal resistance from junction to lead	220	°C/W

2.6 ESD Classification & Moisture Sensitivity Level

ESD Classification

HBM	Class 1B	Voltage Level: 500 ~ 1000 V
MM	Class A	Voltage Level: <200 V

CAUTION: Gallium Arsenide Integrated Circuits are sensitive to electrostatic discharge (ESD) and can be damaged by static electricity. Proper ESD control techniques should be used when handling these devices.

Moisture Sensitivity Level

MSL 3 at 260 °C reflow

(Intentionally Blanked)

3. Application: 500 ~ 3500 MHz ($V_{\text{supply}} = +3.3 \text{ V}$)

3.1 Application Circuit & Evaluation Board

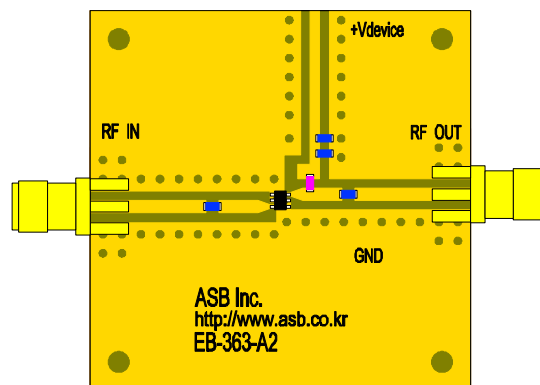
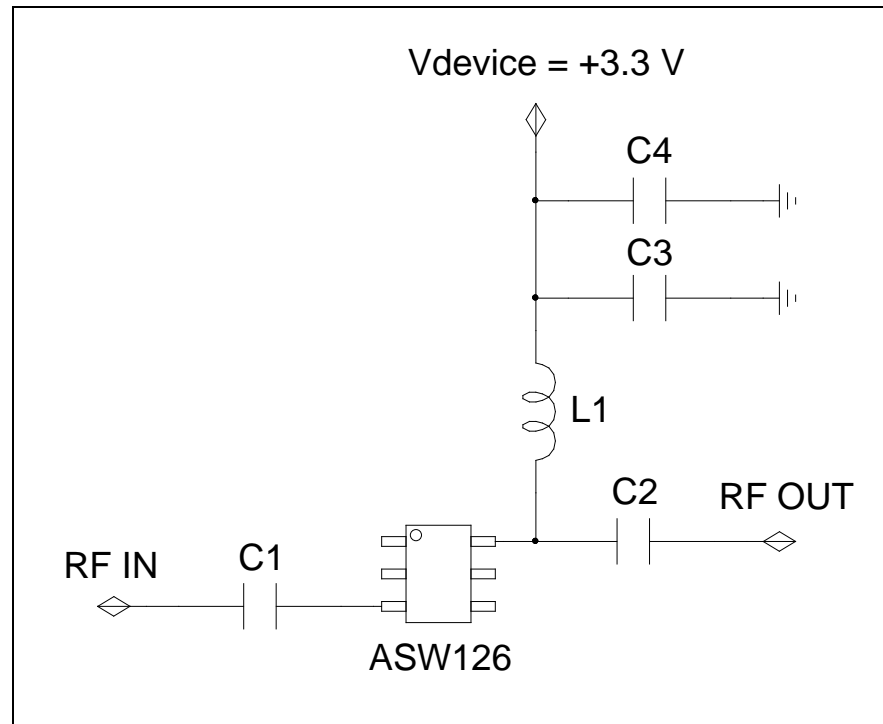

PCB Information	
Material	FR4
Thickness (mm)	0.8
Size (mm)	40x40
EB No.	EB-363-A2

Bill of Material

Symbol	Value	Size	Description	Manufacturer
ASW126	-	-	MMIC Amplifier	ASB
C1, C2	1 nF	0603	DC blocking capacitor	Murata
C3	100 pF	0603	Bypass capacitor	Murata
C4	1 μF	0603	Decoupling capacitor	Murata
L1	47 nH	0603	RF choke inductor	Murata

3.2 Performance Table

Supply voltage = +3.3 V, $T_A = +25\text{ }^\circ\text{C}$, $Z_O = 50\ \Omega$.

Parameter	Typical							Unit
Frequency	500	900	1750	2000	2400	2700	3500	MHz
Gain	22.6	20.1	15.5	14.4	12.9	11.8	9.6	dB
S11	-16	-20	-20	-19	-16	-14	-13	dB
S22	-10	-11	-11	-12	-13	-15	-14	dB
Noise Figure	3.8	3.7	3.8	3.9	4.1	4.2	4.3	dB
Output IP3 ¹⁾	30.0	31.0	32.0	33.5	33.5	33.0	33.5	dBm
Output P1dB	16.5	17.0	17.0	17.5	17.5	18.0	17.5	dBm
Current	37							mA
Device Voltage	+3.3							V

1) OIP3 is measured with two tones at the output power of +0 dBm/tone separated by 1 MHz.

3.3 Plot of S-parameter & Stability Factor

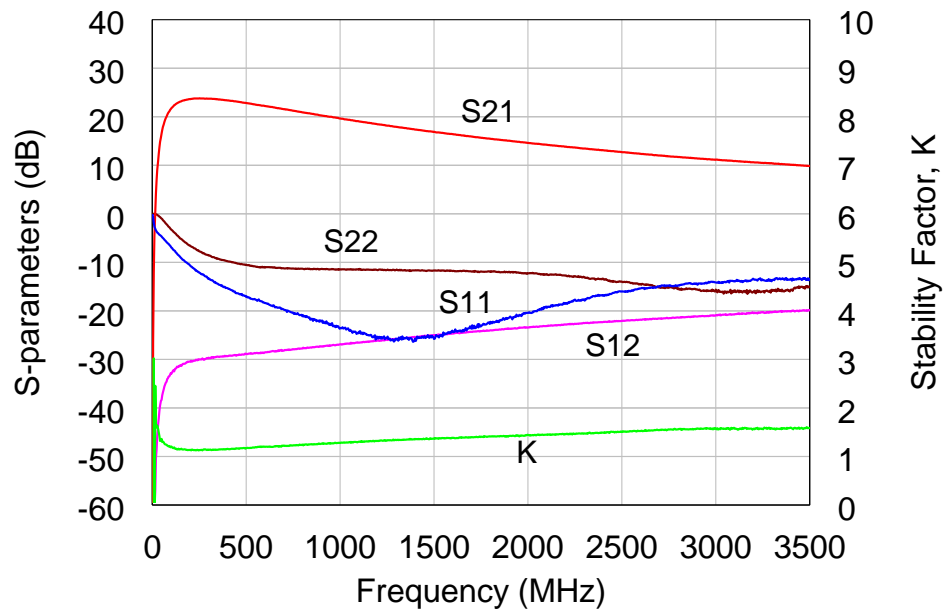

3.4 Plots of Noise Figure and Performances with Temperature

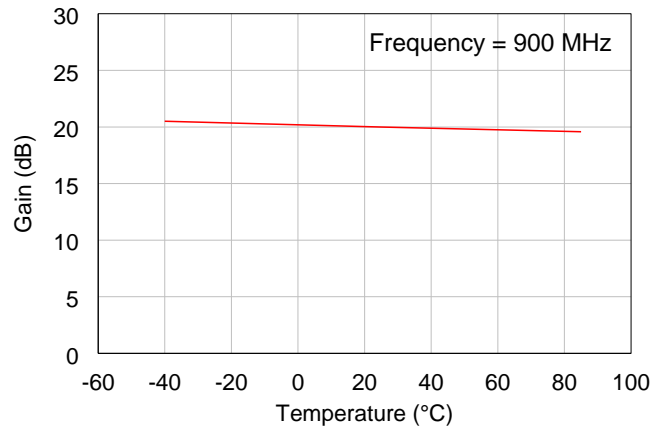
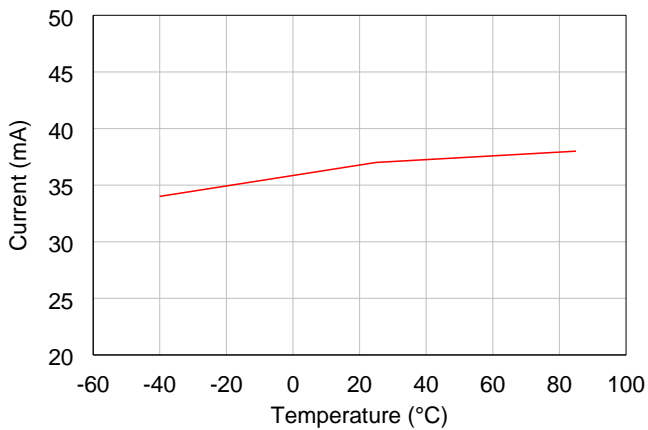
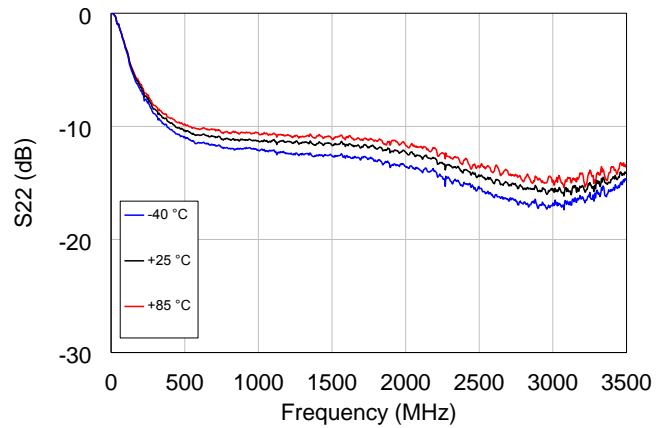
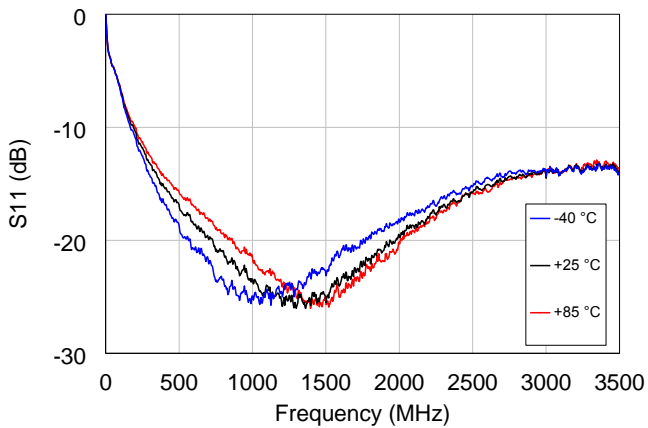
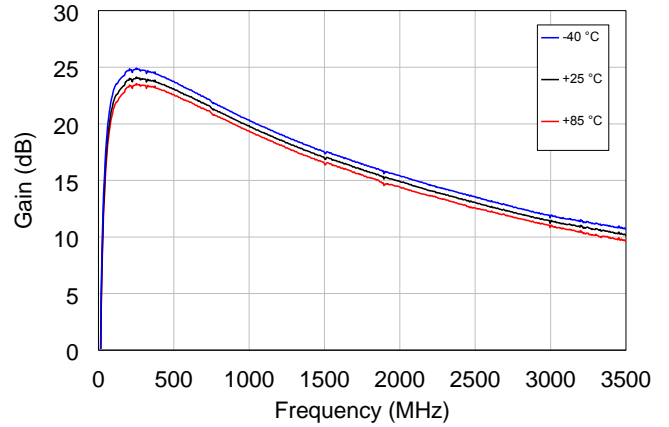
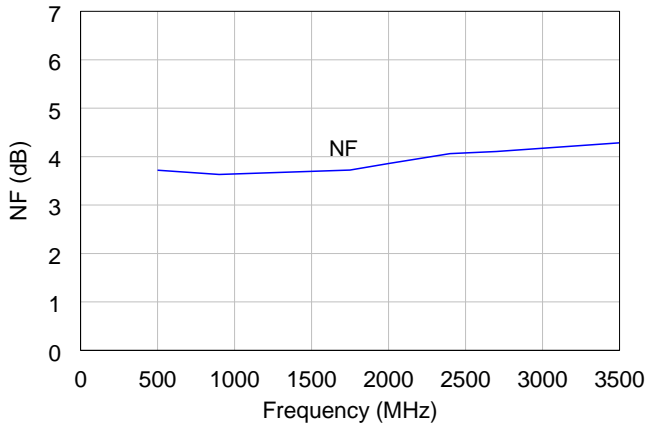

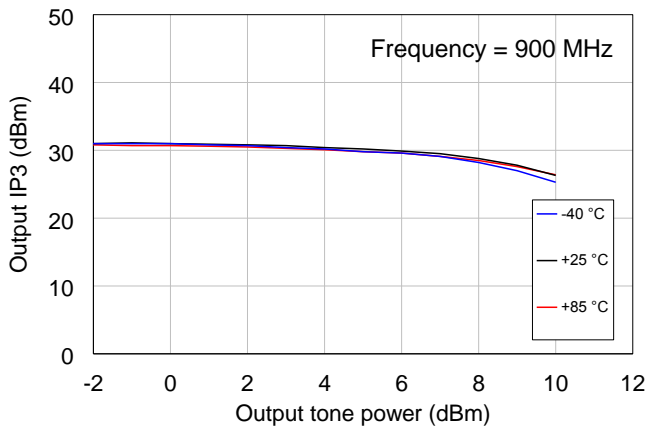
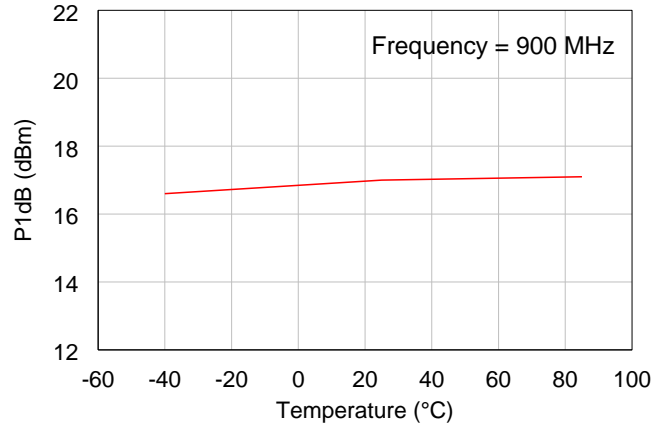
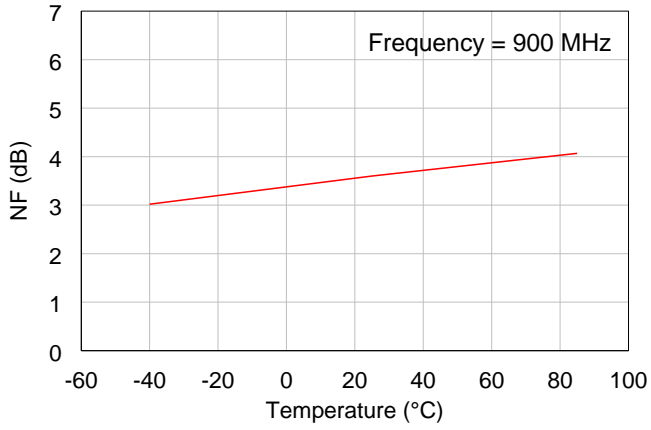

4. Application: 50 ~ 500 MHz (IF, $V_{\text{supply}} = +3.3 \text{ V}$)

4.1 Application Circuit & Evaluation Board

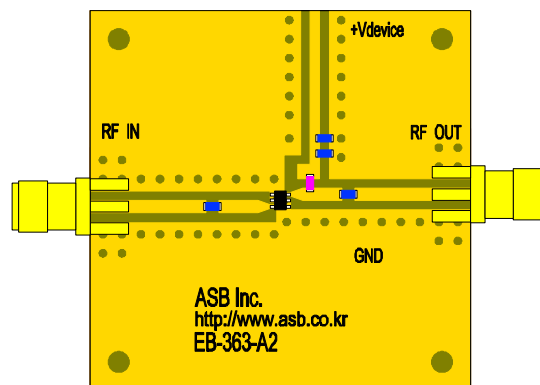
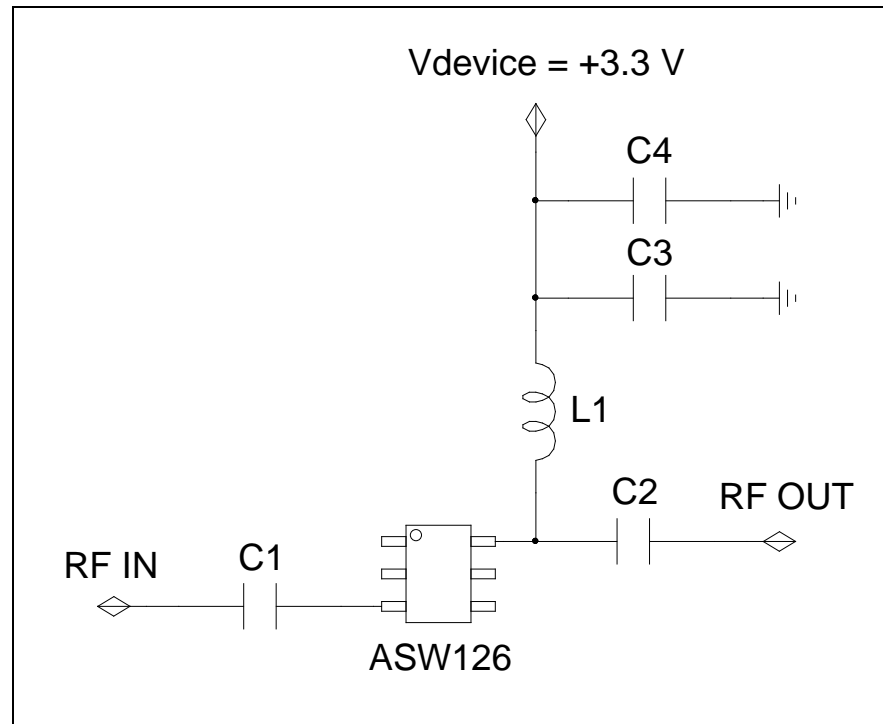

PCB Information

Material	FR4
Thickness (mm)	0.8
Size (mm)	40x40
EB No.	EB-363-A2

Bill of Material

Symbol	Value	Size	Description	Manufacturer
ASW126	-	-	MMIC Amplifier	ASB
C1, C2	1 nF	0603	DC blocking capacitor	Murata
C3	100 pF	0603	Bypass capacitor	Murata
C4	1 μF	0603	Decoupling capacitor	Murata
L1	680 nH	0603	RF choke inductor	Samsung

4.2 Performance Table

Supply voltage = +3.3 V, T_A = +25 °C, Z_O = 50 Ω.

Parameter	Typical				Unit
Frequency	70	150	300	450	MHz
Gain	24.8	24.5	24.0	23.0	dB
S11	-20	-21	-23	-23	dB
S22	-11	-11	-11	-11	dB
Noise Figure	3.6	3.5	3.7	3.7	dB
Output IP3 ¹⁾	27.5	27.5	29.5	28.5	dBm
Output P1dB	16.0	16.0	16.5	16.5	dBm
Current	37				mA
Device Voltage	+3.3				V

1) OIP3 is measured with two tones at the output power of +0 dBm/tone separated by 1 MHz.

4.3 Plot of S-parameter & Stability Factor

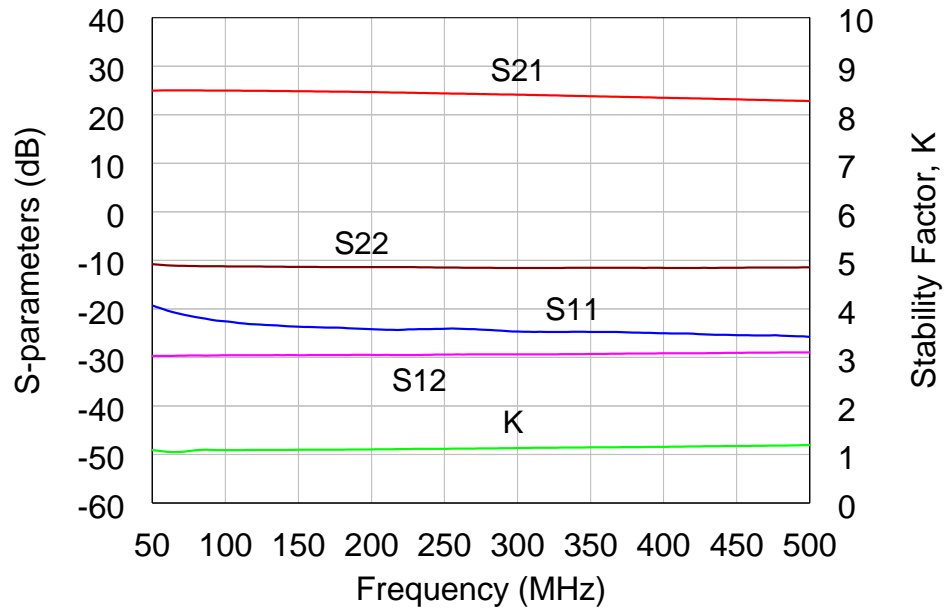

5. Package Outline (SOT363, 2.1x2.0x1.0 mm)

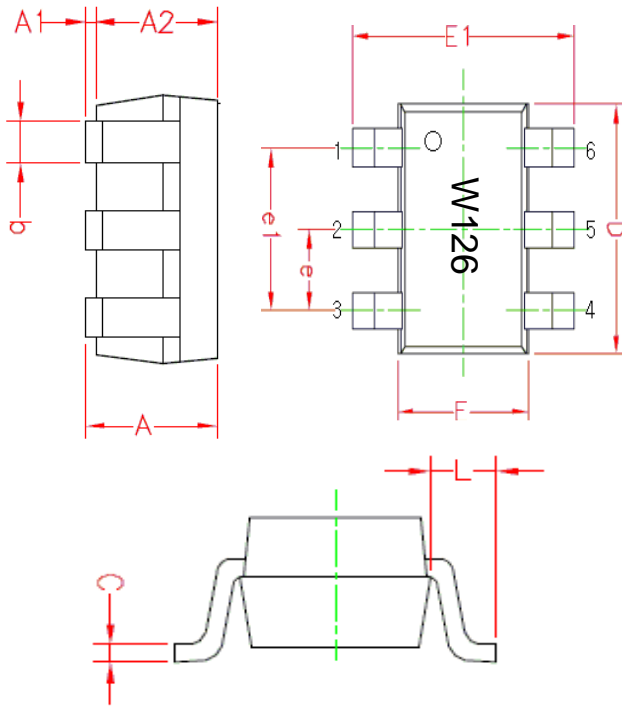

Symbols	Dimensions (In mm)		
	MIN	NOM	MAX
A	0.900	1.000	1.10
A1	0.025	0.062	0.10
A2	0.875	0.937	1.00
b	0.200	0.300	0.40
C	0.100	0.125	0.15
D	1.900	2.000	2.10
F	1.150	1.250	1.35
E1	2.000	2.100	2.20
e	0.65BSC		
e1	1.30BSC		
L	0.425REF		

6. Surface Mount Recommendation (In mm)

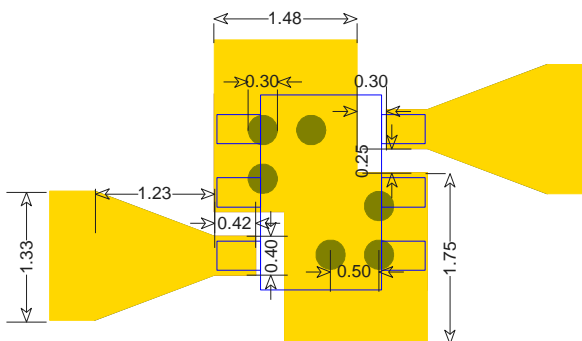

NOTE

1. The number and size of ground via holes in a circuit board are critical for thermal and RF grounding considerations.
2. Recommend is that the ground via holes be placed on the bottom of the ground leads and exposed pad of the device for better RF and thermal performance, as shown in the drawing at the left side.

7. Recommended Soldering Reflow Profile

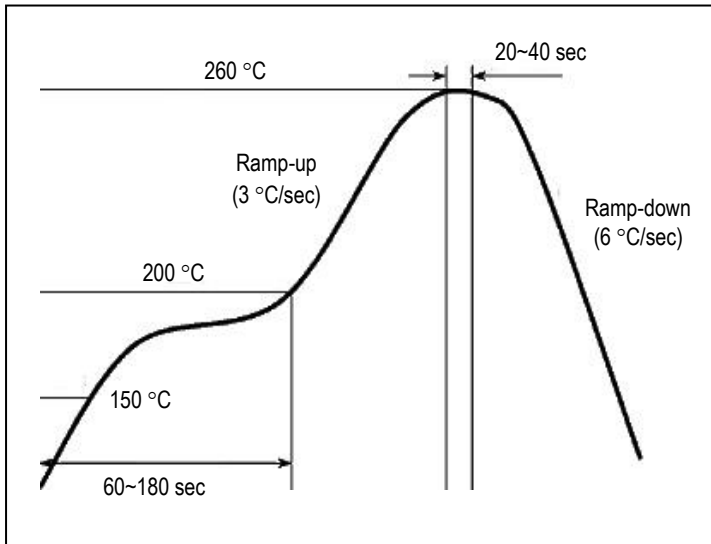

(End of Datasheet)