

# CMOS 5GHz WLAN 802.11ac RFeIC with PA, LNA and SPDT

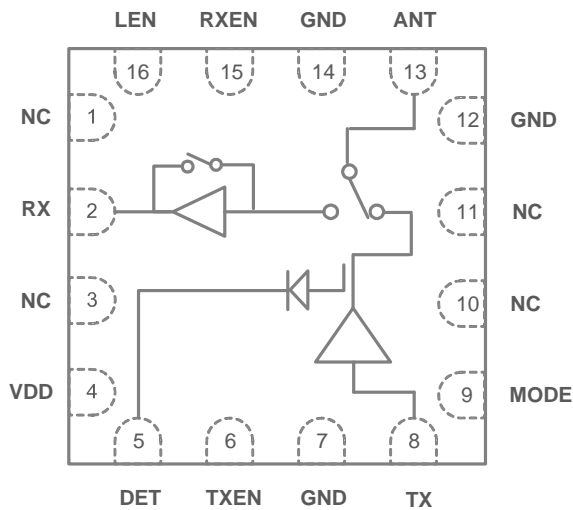

## Description

RFX8050 is a highly integrated, single-chip, single-die RFeIC (RF Front-end Integrated Circuit) which incorporates key RF functionality needed for IEEE 802.11a/n/ac WLAN system operating in the 5.15-5.85GHz range. The RFX8050 architecture integrates a high-efficiency, high-linearity power amplifier (PA), a low noise amplifier (LNA) with bypass, the associated matching network, LO rejection, and harmonic filters all in a CMOS single-chip device.

RFX8050 has simple and low-voltage CMOS control logic, and requires minimal external components. A directional coupler based power detect circuit is also integrated for accurate monitoring of output power from the PA.

RFX8050 is assembled in an ultra-compact, low-profile 2.5x2.5x0.45 mm 16-lead QFN package. With support to direct battery operation, the RFX8050 is ideal RF front-end solution for implementing 5GHz WLAN in smartphones and other mobile platforms.

## Applications

- ▶ 802.11a/n/ac
- ▶ Smartphones
- ▶ Tablets/MIDs
- ▶ Gaming
- ▶ Notebook/Netbook/Ultrabooks
- ▶ Mobile/Portable Devices
- ▶ Consumer Electronics
- ▶ Other 5GHz ISM Platforms

Parameters	Typical	Conditions
<b>TX</b>		
Small-Signal Gain	28dB	
Quiescent Current	145mA	
Linear Output Power for 11a	+17dBm	High-Linearity Mode, EVM<3%, 802.11a 54Mbps/64QAM/20MHz, VDD=3.6V
Linear Output Power for 11ac	+16dBm	High-Linearity Mode, EVM<1.8%, 802.11ac MCS9/256QAM/80MHz, VDD=3.6V
TX Linear Current	205mA	At Pout=+17dBm, High-Linearity Mode
2 <sup>nd</sup> and 3 <sup>rd</sup> Harmonic	-30/-35dBc	At Pout=+20dBm, CW
<b>RX</b>		
Small-Signal Gain	12dB	High Gain Mode, Between ANT and RX pins; RXEN=LEN="High"
Noise Figure	3.3dB	High Gain Mode, At ANT Pin
Quiescent Current	13mA	No RF Applied, Through VDD, High Gain Mode
Bypass Insertion Loss	5dB	Between ANT and RX Pins; RXEN="High", LEN="Low"
<b>CHIP</b>		
Operating Frequency	5.15-5.85GHz	
Supply VDD	3.0V – 4.8V	Nominal VDD=3.6V
Shut-down Current	3uA	
RF Port Impedance	50-Ohm	Single-ended
Control Signals	High Enable	CMOS Logic, <0.3V Low, >1.2V High
Package	16-QFN	2.5mm x 2.5mm x 0.45mm

RFeIC® is a registered trademark of RFaxis, Inc. All rights reserved.

This product brief is a general list of parameters to provide information on the capabilities of this device and is subject to change without notice.