

## SF2331B

## 246 MHz SAW Filter

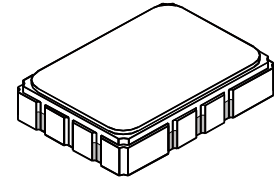

SMP-03

- **Narrow-band SAW Filter**
- **5 x 7 mm Surface-mount Package**
- **Complies with Directive 2002/95/EC (RoHS)**



### Absolute Maximum Ratings

Rating	Value	Units
Maximum Incident Power in Passband	0	dBm
Maximum DC Voltage on any Non-ground Terminals	3	VDC
Storage Temperature Range in Tape and Reel	-40 to +85	°C
Suitable for Lead-free Soldering - Maximum Soldering Profile	260 °C for 30 s	

### Electrical Characteristics

Characteristic	Sym	Notes	Min	Typ	Max	Units
Center Frequency	$f_C$	1		246		MHz
Minimum Insertion Loss	$IL_{MIN}$			5.0	6.5	dB
3 dB Bandwidth	$BW_3$				600	
Amplitude Ripple, $f_C \pm 225$ kHz				1.2	2.0	dB <sub>P-P</sub>
Rejection Referenced to $IL_{MIN}$ :						dB
10 MHz to $f_C$ -20 MHz			45.0	55.0		
$f_C$ -20MHz to $f_C$ -1.2MHz			40.0	45.0		
$f_C$ +1.2MHz to $f_C$ +20MHz			40.0	45.0		
$f_C$ +20MHz to 1GHz			45.0	55.0		
Operating Temperature Range			-20		+70	°C

Case Style	SMP-03 7 x 5 mm Nominal Footprint					
Lid Symbolization (Y=year, WW=week) dot=pin 1 indicator	RFM/SF2331B/YYWW					
Standard Reel Quantity	Reel Size 7 Inch	500 Pieces/Reel				
	Reel Size 13 Inch	3000 Pieces/Reel				

### Electrical Connections

Connection	Terminals
Input Port	10
Output Port	5
Ground	All others



**CAUTION: Electrostatic Sensitive Device. Observe precautions for handling.**

#### NOTES:

- Unless noted otherwise, all specifications apply over the operating temperature range with filter soldered to the specified demonstration board with impedance matching to 50  $\Omega$  and measured with 50  $\Omega$  network analyzer.
- Unless noted otherwise, all frequency specifications are referenced to the nominal center frequency,  $f_C$ .
- Rejection is measured as attenuation below the minimum IL point in the passband. Rejection in final user application is dependent on PCB layout and external impedance matching design. See Application Note No. 42 for details.
- The design, manufacturing process, and specifications of this filter are subject to change.
- Either Port 1 or Port 2 may be used for either input or output in the design. However, impedances and impedance matching may vary between Port 1 and Port 2, so that the filter must always be installed in one direction per the circuit design.
- US and international patents may apply.
- Murata, stylized Murata logo, and Murata N.A., Inc. are registered trademarks of Murata Manufacturing Co., Ltd.

# Typical Tuning Network

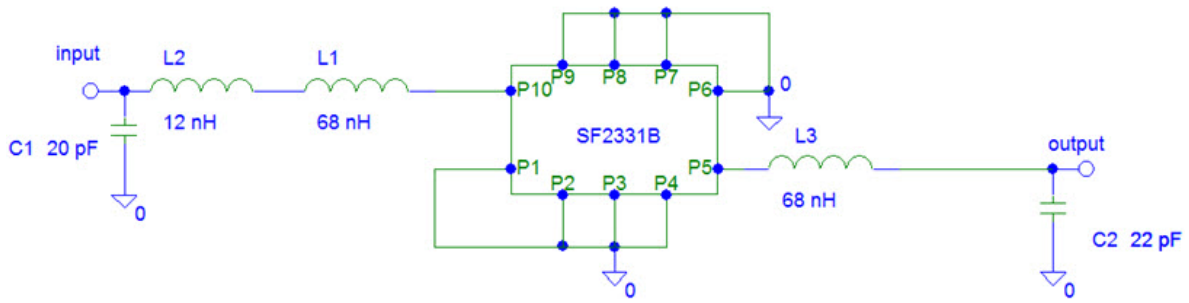

# Filter Response Plot

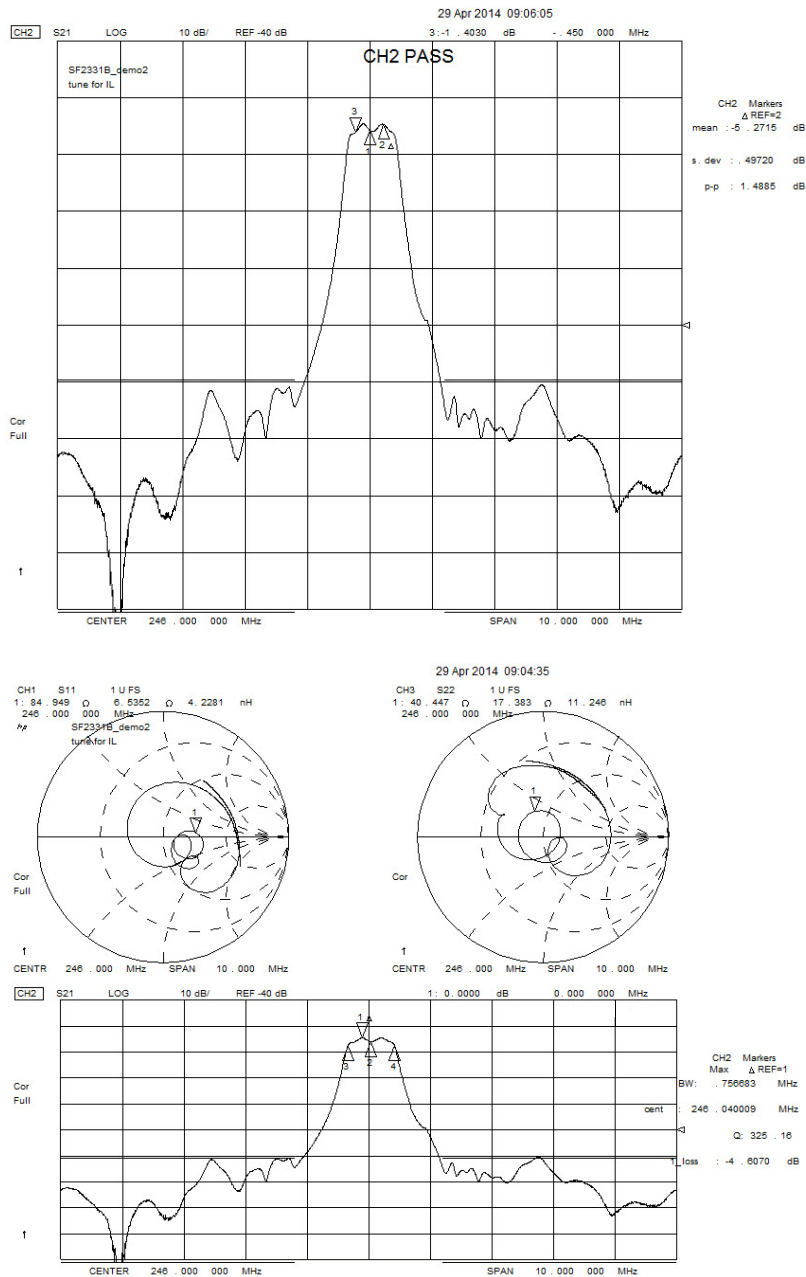

# SMP-03 10-Terminal Ceramic Surface-mount Case

## 5 x 7 mm Nominal Footprint

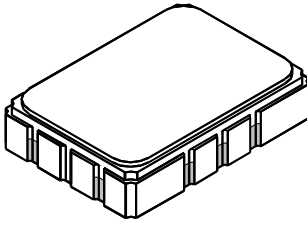

### Recommended PCB Footprint

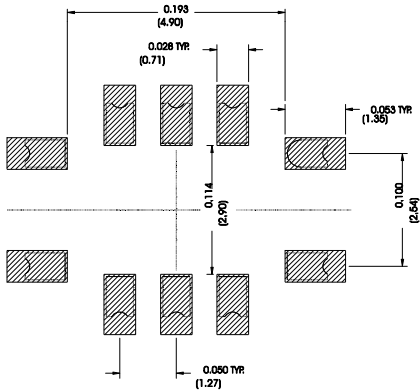

Case Dimensions						
Dimension	mm			Inches		
	Min	Nom	Max	Min	Nom	Max
A	6.80	7.00	7.20	0.268	0.276	0.283
B	4.80	5.00	5.20	0.189	0.197	0.205
C	-	1.65	2.00	-	0.065	0.079
D	0.47	0.60	0.73	0.019	0.024	0.029
E	2.41	2.54	2.67	0.095	0.100	0.105
H	0.87	1.0	1.13	0.034	0.039	0.044
J	4.87	5.00	5.13	0.192	0.197	0.202
K	2.87	3.00	3.13	0.113	0.118	0.123
P	1.14	1.27	1.40	0.045	0.050	0.055

Electrical Connections		
Connection		Terminals
Port 1	Single-ended Input	10
Port 2	Single-ended Output	5
	Ground	All others

Case Materials	
Solder Pad Plating	0.3 to 1.0 $\mu\text{m}$ Gold over 1.27 to 8.89 $\mu\text{m}$ Nickel
Lid Plating	2.0 to 3.0 $\mu\text{m}$ Nickel
Body	$\text{Al}_2\text{O}_3$ Ceramic
	Pb Free

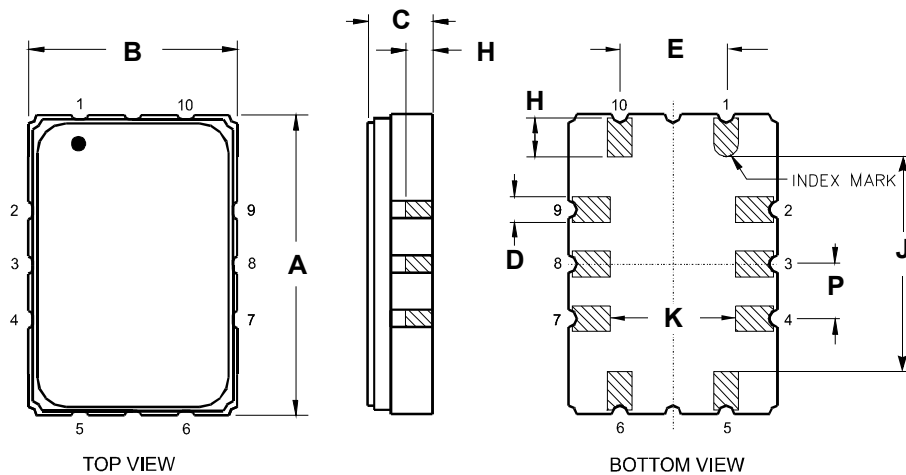

# Tape and Reel Specifications

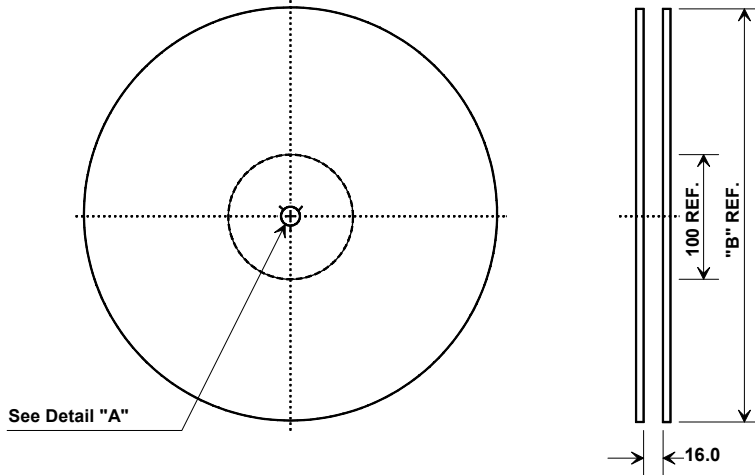

"B"		Quantity Per Reel
Nominal Size		
Inches	millimeters	
7	178	500
13	330	2000

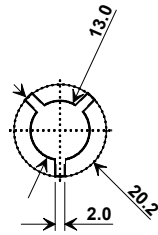

## COMPONENT ORIENTATION and DIMENSIONS

Carrier Tape Dimensions	
Ao	5.6 mm
Bo	7.6 mm
Ko	2.0 mm
Pitch	8.0 mm
W	16.0 mm

