

# Keysight Technologies

## M9169E

### PXI Switchable-Input Programmable Step Attenuator Module, DC to 50 GHz

#### Industries and Applications

- RF signal path attenuation simulation
- Spectrum analyzer input signal conditioning
- RF receiver sensitivity test
- Adjacent channel interference

#### Product Description

In addition to connectorized standalone attenuators, Keysight Technologies, Inc. also offers PXI step attenuator modules that operate across a broad frequency range of DC to 50 GHz. The M9169E is a 3-port PXI programmable step attenuator module with a switchable path. This is ideal for switching in a calibrator signal (cal input) into the input of a signal analyzer to improve amplitude accuracy. The M9169E has a 0.03 dB insertion loss repeatability throughout the operating life of up to 5 million cycles per section. The M9169E has excellent attenuation accuracy across a wide operating temperature range ensures precise measurements.

#### Features and Benefits

Product features	Your benefit
0.03 dB insertion loss repeatability throughout the operating life	Minimize system measurement uncertainty
Long operating life of 5 million cycles	Reduce cost of test and increase reliability over test system's life expectancy
High attenuation accuracy and flatness	Superior attenuation accuracy ensures precise measurements

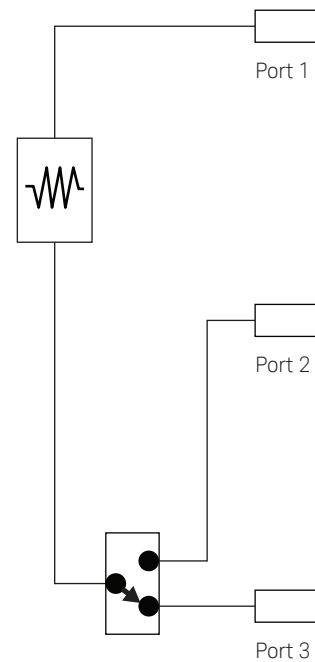

Schematic diagram for the M9169E



Unlocking Measurement Insights

## Hardware

Size	2 slots wide module
Frequency range	DC to 50 GHz
Attenuation range	0 to 70 dB
Attenuation resolution	2 dB, 6 dB, and 10 dB step
Repeatability	0.03 dB
Lifecycle	5 million life cycles per section
Insertion loss	DC to 40 GHz: $2.2 + 0.1 f$ (f in GHz) 40 to 50 GHz: $2.2 + 0.124 f$ (f in GHz)
Return loss (VSWR)	DC to 18 GHz: 15 dB (1.43) 18 to 26.5 GHz: 8.5 dB (2.20) 26.5 to 40 GHz: 6.5 dB (2.80) 40 to 50 GHz: 3.5 dB (5.03)
Maximum input power	1 W (+30 dBm) average 50 W peak (10 $\mu$ s max)
Maximum reverse power	1 W (+30 dBm) average 50 W peak (10 $\mu$ s max)
Switching speed	20 ms
RF connector	2.4 mm (f)
Connector compatibility	cPCI, PXI-H, PXI-1

## Attenuation Accuracy

Specified across operating frequency of 0 to 50 °C

Attenuation setting for step ranges (dB)	DC to 18 GHz	18 to 26.5 GHz	26.5 to 40 GHz	40 to 50 GHz
2	0.45	0.50	0.80	1.10
4 to 8	0.65	0.75	1.10	1.80
10 to 12	0.85	0.95	1.10	1.80
14 to 18	0.85	0.95	1.10	2.00
20 to 30	1.15	1.25	1.40	2.00
32 to 38	1.40	1.50	1.65	2.05
40 to 44	1.60	1.70	1.85	2.15
46 to 48	1.60	1.70	1.85	2.45
50 to 58	2.03	2.13	2.30	3.13
60 to 68	2.28	2.38	2.55	3.22
70	2.45	2.55	2.70	3.31

## Software

Software development platform	Microsoft Visual Studio with C/C++, Microsoft Visual Studio .NET with C# or Visual Basic, National Instruments LabVIEW, National Instruments, LabWindows CVI, The MathWorks MATLAB, Keysight VEE
Supported operating systems	Windows XP SP3, 32-bit; Windows Vista 32-bit and 64-bit; Windows 7 32-bit and 64-bit
Drivers provided	IVI-COM, IVI-C, LabVIEW, MATLAB
Included GUI	Soft front panel
Application code examples	C, C++, C#, Visual Basic, VEE, MATLAB

## Recommended Configuration

M9018A	PXIe Chassis, 18-slots, 4U, 8 GB/s
M9393A	PXIe Performance Vector Signal Analyzer: 9 kHz to 27 GHz
M9300A	PXIe Frequency Reference: 10 MHz and 100 MHz
M9037A	PXIe High Performance Embedded Controller
M9169E	PXI Switchable-Input Programmable Step Attenuator Module, DC to 50 GHz

## Related Products

M9362AD01	PXIe Quad Downconverter: 10 MHz to 50 GHz
M9352A	PXI Hybrid Amplifier/Attenuator
M9155/6/7C	PXI Switch Modules, DC to 26.5 GHz

For more information on Keysight Technologies' products, applications or services, please contact your local Keysight office. The complete list is available at: [www.keysight.com/find/contactus](http://www.keysight.com/find/contactus)

### Americas

Canada	(877) 894 4414
Brazil	55 11 3351 7010
Mexico	001 800 254 2440
United States	(800) 829 4444

### Asia Pacific

Australia	1 800 629 485
China	800 810 0189
Hong Kong	800 938 693
India	1 800 11 2626
Japan	0120 (421) 345
Korea	080 769 0800
Malaysia	1 800 888 848
Singapore	1 800 375 8100
Taiwan	0800 047 866
Other AP Countries	(65) 6375 8100

### Europe & Middle East

Austria	0800 001122
Belgium	0800 58580
Finland	0800 523252
France	0805 980333
Germany	0800 6270999
Ireland	1800 832700
Israel	1 809 343051
Italy	800 599100
Luxembourg	+32 800 58580
Netherlands	0800 0233200
Russia	8800 5009286
Spain	800 000154
Sweden	0200 882255
Switzerland	0800 805353
	Opt. 1 (DE)
	Opt. 2 (FR)
	Opt. 3 (IT)
United Kingdom	0800 0260637

For other unlisted countries:  
[www.keysight.com/find/contactus](http://www.keysight.com/find/contactus)  
 (BP-04-23-15)

**myKeysight**  
[www.keysight.com/find/mykeysight](http://www.keysight.com/find/mykeysight)  
 A personalized view into the information most relevant to you.

**www.pxisa.org**  
 PCI eXtensions for Instrumentation (PXI) modular instrumentation delivers a rugged, PC-based high-performance measurement and automation system.

**www.keysight.com/go/quality**  
 Keysight Technologies, Inc.  
 DEKRA Certified ISO 9001:2008  
 Quality Management System

**Keysight Infoline**  
[www.keysight.com/find/service](http://www.keysight.com/find/service)  
 Keysight's insight to best in class information management. Free access to your Keysight equipment company reports and e-library.

**Keysight Channel Partners**  
[www.keysight.com/find/channelpartners](http://www.keysight.com/find/channelpartners)  
 Get the best of both worlds: Keysight's measurement expertise and product breadth, combined with channel partner convenience.

[www.keysight.com/find/mta](http://www.keysight.com/find/mta)  
[www.keysight.com/find/modular](http://www.keysight.com/find/modular)  
[www.keysight.com/find/PXlattenuator](http://www.keysight.com/find/PXlattenuator)