

Ceramic Low Pass Filter

50Ω DC⁽¹⁾ to 105 MHz

LFCN-105+ LFCN-105



CASE STYLE: FV1206
PRICE: \$3.99 ea. QTY (20)

Maximum Ratings

Operating Temperature	-55°C to 100°C
Storage Temperature	-55°C to 100°C
RF Power Input*	8.5W max. at 25°C

* Passband rating, derate linearly to 3.5W at 100°C ambient. Permanent damage may occur if any of these limits are exceeded.

Pin Connections

RF IN	1
RF OUT	3
GROUND	2,4

Outline Drawing

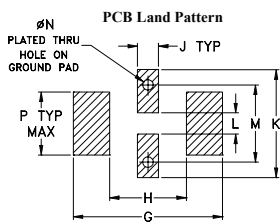
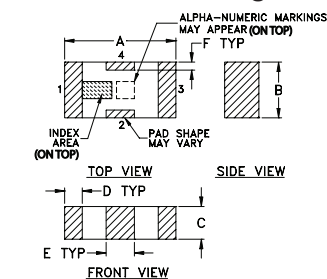

Suggested Layout,
Tolerance to be within ±.002

Outline Dimensions (inch)

A	B	C	D	E	F	G	
.126	.063	.037	.020	.032	.009	.169	
3.20	1.60	0.94	0.51	0.81	0.23	4.29	
H	J	K	L	M	N	P	wt
.087	.024	.122	.024	.087	.012	.071	grams
2.21	0.61	3.10	0.61	2.21	0.30	1.80	.020

Demo Board MCL P/N: TB-270 Suggested PCB Layout (PL-137)

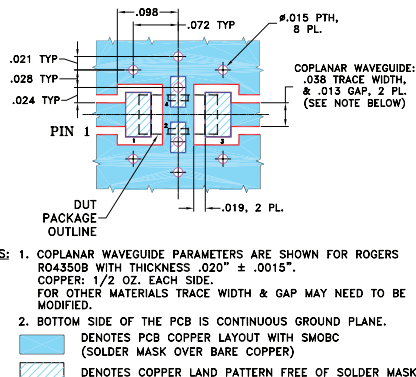

Features

- excellent power handling, 8.5W
- small size
- 7 sections
- temperature stable
- LTCC construction
- protected by U.S. Patent 6,943,646

Applications

- harmonic rejection
- VHF/UHF transmitters/receivers
- RF suppression for DC lines on PCB
- anti-aliasing for A/D converter

Electrical Specifications^(1,2) at 25°C

Parameter	F#	Frequency (MHz)	Min.	Typ.	Max.	Unit	
Pass Band	Insertion Loss	DC-F1	DC-105	—	—	1.0	dB
	Freq. Cut-Off	F2	180	—	3.0	—	dB
	VSWR	DC-F1	DC-105	—	1.2	—	:1
Stop Band	Rejection Loss	F3	250	20	—	—	dB
		F4-F5	265-1650	—	40	—	dB
	VSWR	F6	4750	—	20	—	dB
		F3-F6	250-4750	—	20	—	:1

(1) In Application where DC voltage is present at either input or output ports, coupling capacitors are required.

(2) Measured on Mini-Circuits Characterization Test Board TB-270.

Typical Frequency Response

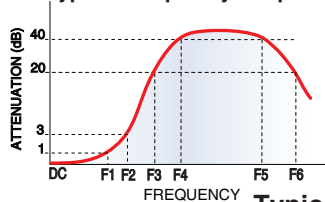

Electrical Schematic

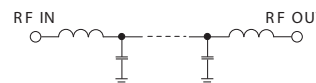

Typical Performance Data at 25°C

Frequency (MHz)	Insertion Loss (dB)	VSWR (:1)
1.00	0.17	1.04
50.00	0.44	1.08
100.00	0.73	1.08
105.00	0.78	1.09
125.00	0.98	1.16
180.00	3.08	1.92
215.00	10.55	2.88
250.00	31.43	4.46
265.00	45.61	5.31
700.00	46.98	56.04
1000.00	55.37	78.97
1650.00	51.39	78.97
2000.00	43.21	82.73
3000.00	31.32	21.73
4750.00	25.73	56.04

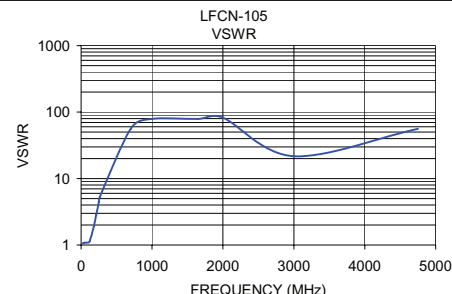
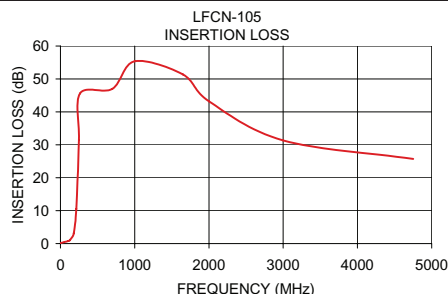

Notes

- A. Performance and quality attributes and conditions not expressly stated in this specification document are intended to be excluded and do not form a part of this specification document.
B. Electrical specifications and performance data contained in this specification document are based on Mini-Circuit's applicable established test performance criteria and measurement instructions.
C. The parts covered by this specification document are subject to Mini-Circuits standard limited warranty and terms and conditions (collectively, "Standard Terms"); Purchasers of this part are entitled to the rights and benefits contained therein. For a full statement of the Standard Terms and the exclusive rights and remedies thereunder, please visit Mini-Circuits' website at www.minicircuits.com/MCLStore/terms.jsp

