



Let Performance Drive

CMD204C3

DC-20 GHz SPST Non-reflective Switch

Features

- ▶ Low loss broadband performance
- ▶ High isolation
- ▶ Fast switching speed
- ▶ Non-reflective design - RF1 and RF2
- ▶ Pb-free RoHS compliant 3x3 SMT package

Applications

- ▶ Microwave radio and VSAT
- ▶ Telecom infrastructure
- ▶ Test instrumentation
- ▶ Military end-use

Description

The CMD204C3 is a general purpose broadband high isolation non-reflective MMIC SPST switch housed in a leadless 3x3 mm surface mount package. Covering DC to 20 GHz, the CMD204C3 features a low insertion loss of 1.3 dB and high isolation of 48 dB at 10 GHz. The CMD204C3 operates using complementary control voltage logic lines of 0/-5 V and requires no bias supply.

Functional Block Diagram

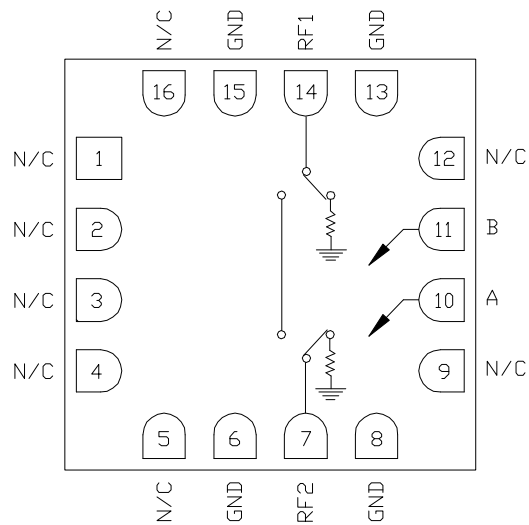

Electrical Performance - $V_{ctl} = 0/-5\text{ V}$, $T_A = 25\text{ }^\circ\text{C}$, $F = 10\text{ GHz}$

Parameter	Min	Typ	Max	Units
Frequency Range	DC - 20			GHz
Insertion Loss		1.3		dB
Isolation		48		dB
Return Loss - On State		15		dB
Return Loss - Off State		22		dB
Input P0.1dB		25		dBm
Switching Speed		1.8		ns

ver 1.0 0414



CMD204C3

DC-20 GHz SPST Non-reflective Switch

Specifications

Absolute Maximum Ratings

Parameter	Rating
RF Input Power	+27 dBm
Control Voltage Range (A,B)	+0.5V to -7.5V
Channel Temperature, T _{ch}	150 °C
Operating Temperature	-40 to 85 °C
Storage Temperature	-55 to 150 °C

Operation of this device outside the maximum ratings may cause permanent damage.

Control Voltages

State	Bias Condition
Low	0 to -0.5V @ 1 uA Typ
High	-3V @ 1 uA Typ to -7V @ 6 uA Typ

Truth Table

Control Input		Signal Path State
A	B	RF1 to RF2
High	Low	On
Low	High	Off

Electrical Specifications - V_{ctl} = 0/-5 V, T_A = 25 °C

Parameter	Min	Typ	Max	Min	Typ	Max	Units
Frequency Range	DC - 10			10 - 18			GHz
Insertion Loss		1.0	1.7		1.5	2.0	dB
Isolation	43	50		35	43		dB
Return Loss - On State		20			12		dB
Return Loss - RF1, 2 - Off State		18			18		dB
Input P _{0.1dB}		24			22		dBm
Input IP3		38			37		dBm
Switching Speed		1.8			1.8		ns

ver 1.0 0414

Typical Performance

Insertion Loss vs. Temperature

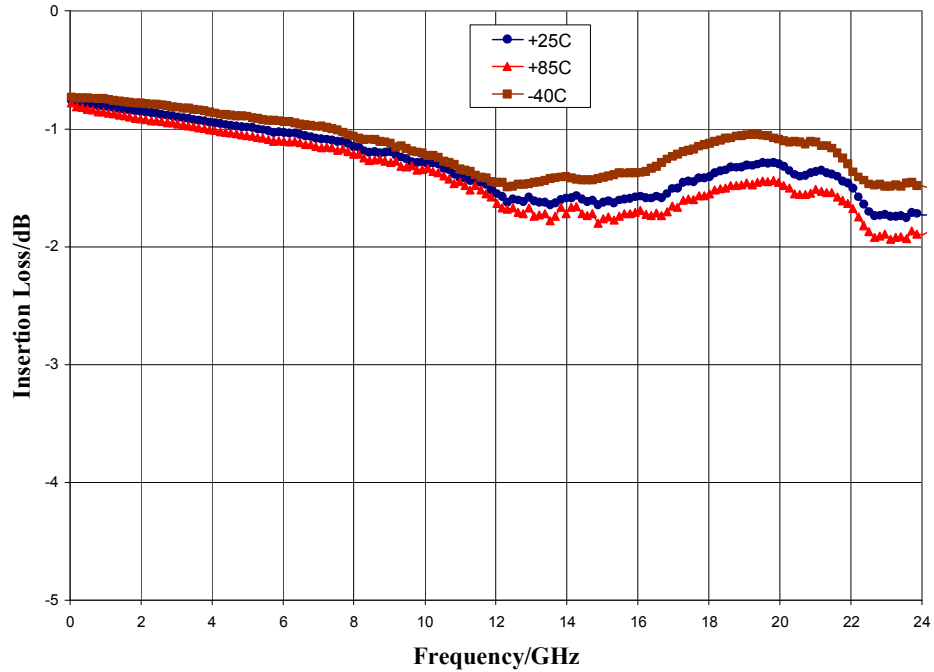

Return Loss

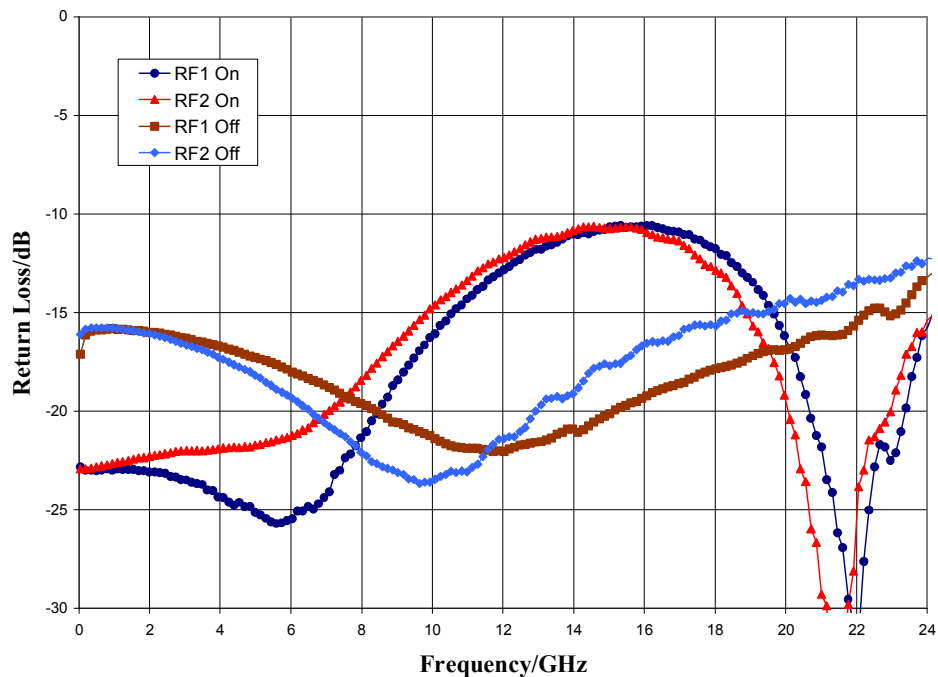

ver 1.0 0414

Typical Performance

Isolation Between Ports RF1 and RF2

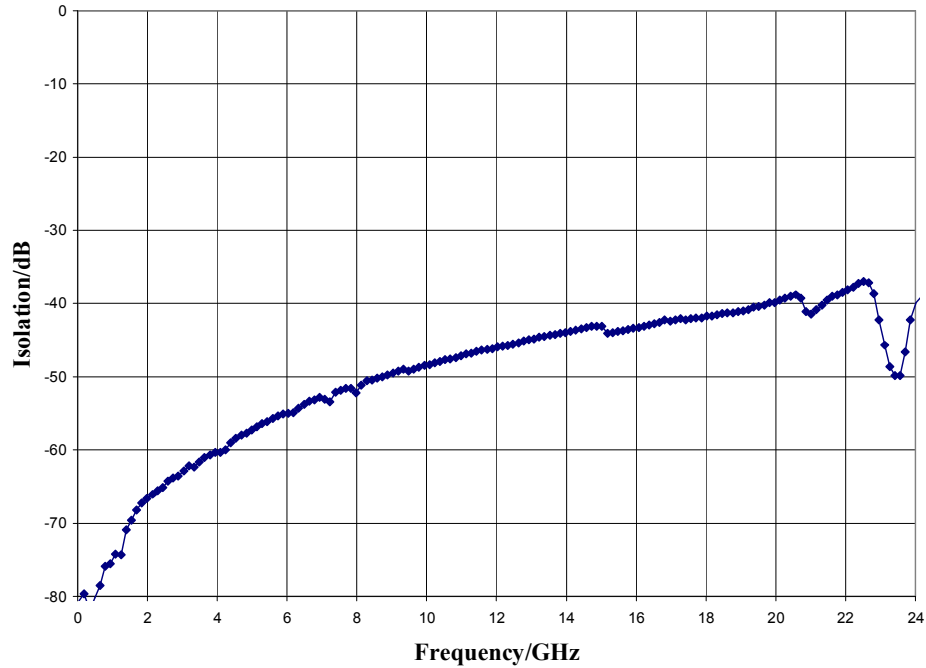

Input P0.1dB Compression Point vs. Temperature

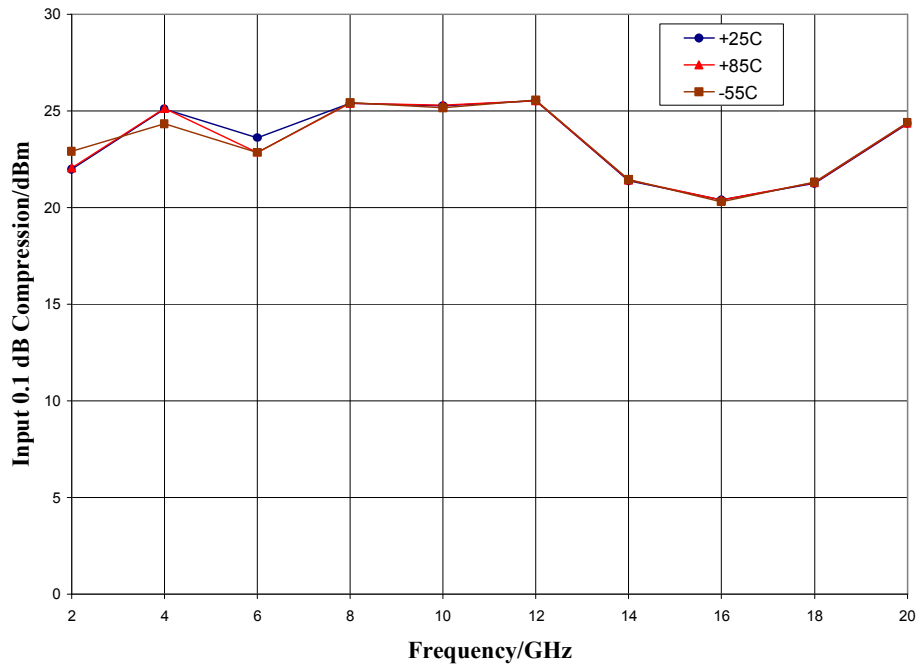

ver 1.0 0414

Typical Performance

Input Third Order Intercept Point vs. Temperature

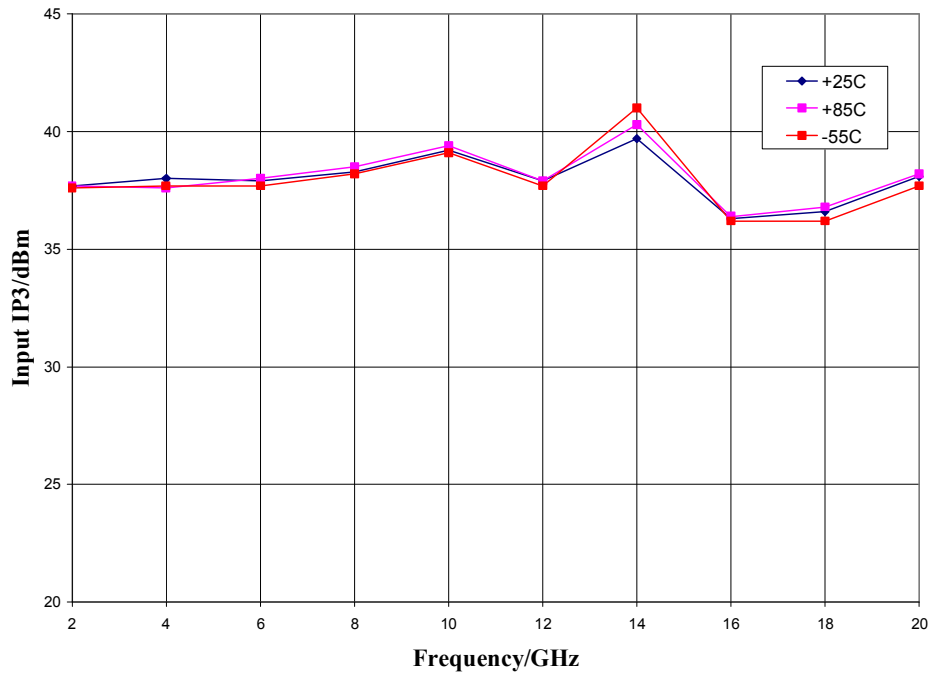

Mechanical Information

Package Information and Dimensions

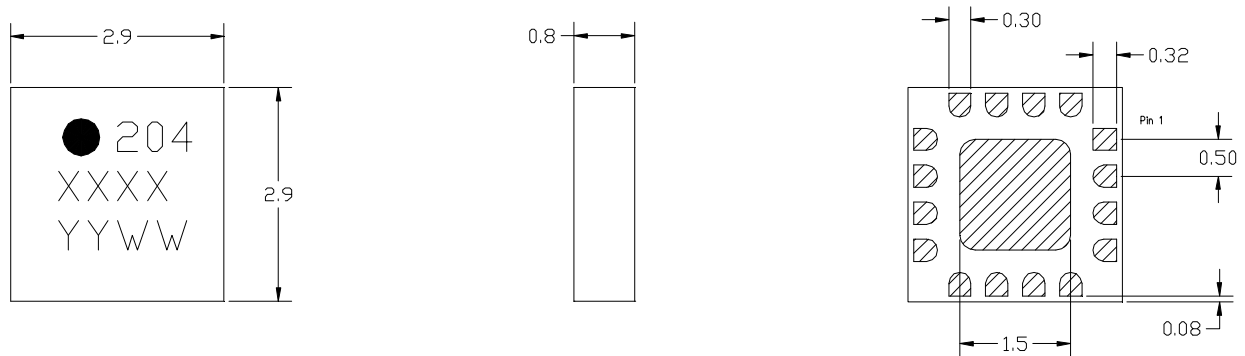

NOTES:

1. DIMENSIONS ARE IN MILLIMETERS
2. MATERIAL: BLACK ALUMINA
3. LEAD FINISH: 30-80 MICROINCHES GOLD OVER 50 MICROINCHES NICKEL.
4. ALTERNATE PIN #1 IDENTIFIER IS SINGLE SQUARE PAD.

Recommended PCB Land Pattern

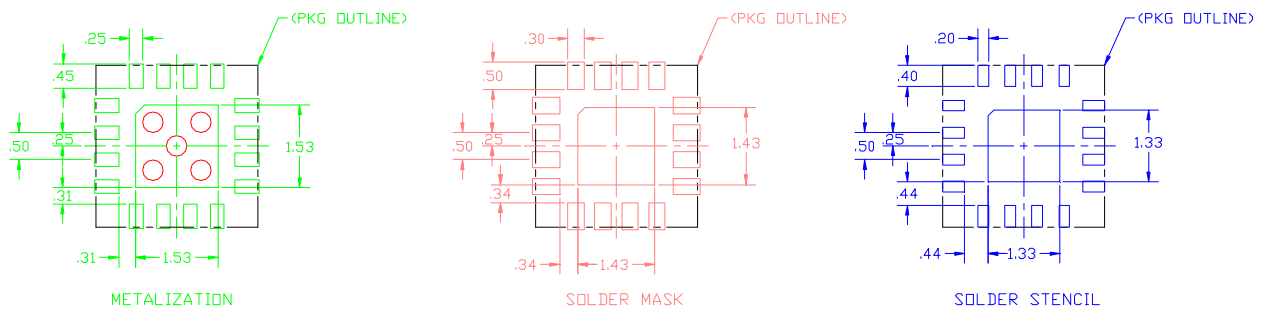

ver 1.0 0414

Pin Description

Pin Diagram

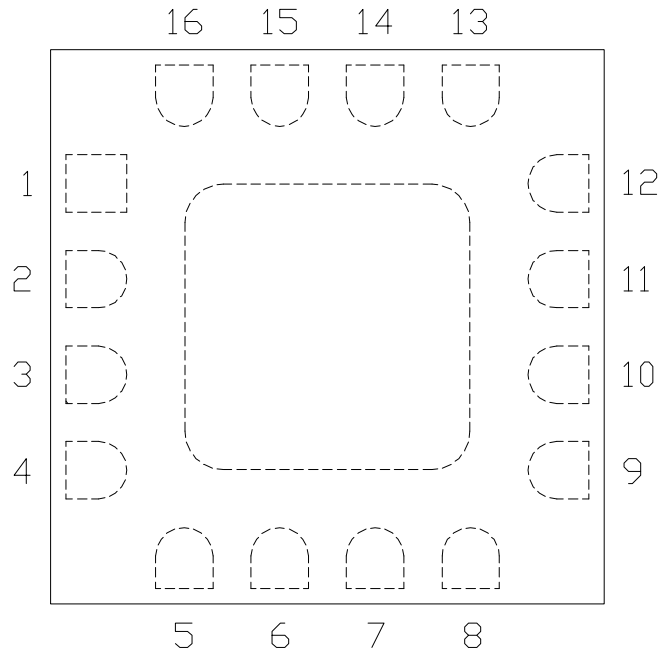

Functional Description

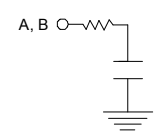
Pin	Function	Description	Schematic
1-5,9,12,16	N/C	No connection required. These pins may be connected to RF/DC ground	
6,8,13,15 and die paddle	Ground	Connect to RF / DC ground	
7,14	RF2, RF1	These pins are DC coupled and matched to 50 Ohm. Blocking capacitors are required if RF line potential is not equal to 0V	
10	CTLA	See truth table and control voltage table	
11	CTLB	See truth table and control voltage table	

ver 1.0 0414

Applications Information

Suggested Driver Circuit

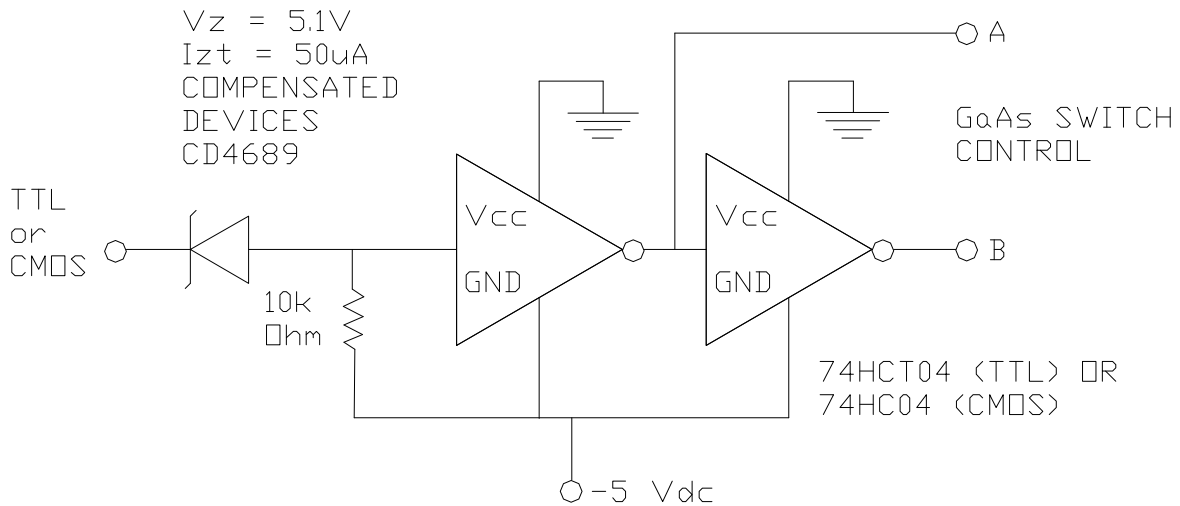

GaAs MMIC devices are susceptible to damage from Electrostatic Discharge. Proper precautions should be observed during handling, assembly and test.

ver 1.0 0414

Applications Information

Evaluation Board

The circuit board shown has been developed for optimized assembly at CMDS. A sufficient number of via holes should be used to connect the top and bottom ground planes. As surface mount processes vary, careful process development is recommended.

P1	DESCRIPTION
1	GND
2	A
3	N/C
4	N/C
5	GND
6	B

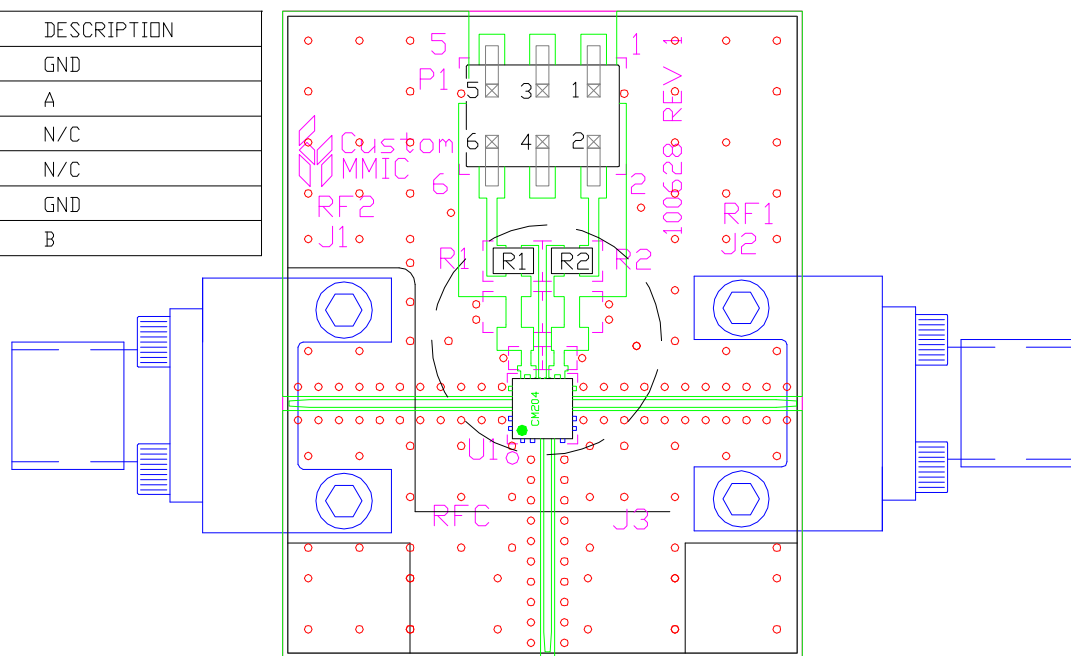

Bill of Material

Designator	Value	Description
J1, J2		SMA End Launch Connector
P1		6 Pin Header
R1, R2	100 Ω	Resistor, 0805
U1		CMD204C3 SPST Switch
PCB		100628 Evaluation PCB