

HIGH POWER PHASE SHIFTER TUNER--- RFPSHT0001W4

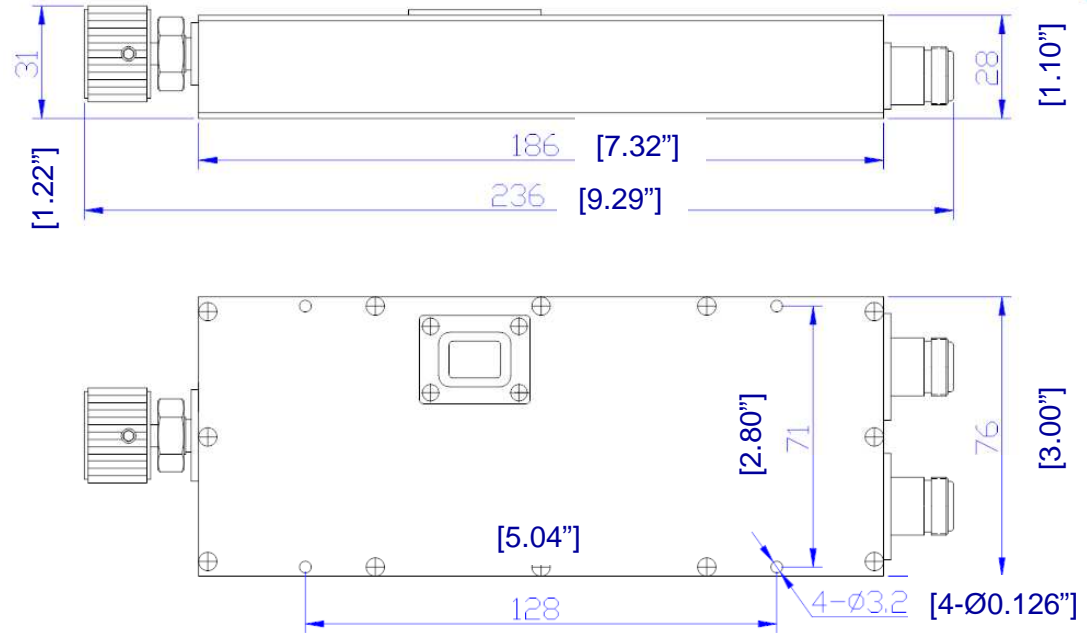
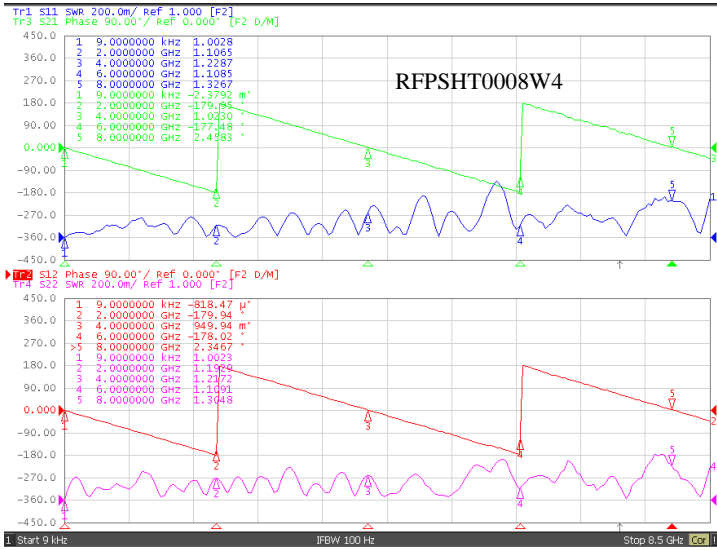

1.0 Mechanical Specifications		
1.1	Connector	N (SMA model optional)
1.2	Size	7.95" x 3.46" x 1.97" (202 x 88 x 50mm)
1.3	Weight	1250g
1.4	External Finish	Body painted with blue/black epoxy enamel

2.0 Environment specifications		
2.1	Oper. Temp.	-10°C~+50°C
2.2	Storage Temp.	-40°C~+70°C
2.3	Altitude	45000 ft
2.4	Vibration	10g rms (15 degree 2KHz)
2.5	Humidity	100% RH at 35c, 95%RH at 40 deg c
2.6	Shock	20G for 11msc

3.0 Electrical Specifications						
Part Number	Frequency (GHz)	Insertion Loss (dB)	Phase Adjustment	VSWR max.	Average Power (W)	Peak Power (KW)
RFPSHT0001W4	DC-1	<0.5	90° ***	1.2	100	5
***Phase Adjustment Range specification ONLY refer to the highest frequency point. Total Phase Adjustment Range is proportion of Frequency range. HALF the frequency range, HALF of the phase adjustment range. (For example 8GHz range 360°, then 4GHz will be 180° total range)						

PAGE 1 OF 1	DATE Oct 8 th 2006
<small>PROPRIETARY INFORMATION THE INFORMATION CONTAINED IN THIS DOCUMENT IS THE PROPERTY OF RF-LAMBDA EXCEPT AS SPECIFICALLY AUTHORIZED IN WRITING BY RF-LAMBDA. THE HOLDER OF THIS DOCUMENT SHALL KEEP ALL INFORMATION CONTAINED HEREIN CONFIDENTIAL AND SHALL PROTECT SAME IN THE WHOLE OR IN PART FROM DISCLOSURE AND DISSEMINATION OF ALL THIRD PARTIES AND SHALL USE SAME FOR OPERATING AND MAINTENANCE PURPOSES ONLY</small>	
DESIGN RFPFC	CAD MODEL REVISION 10
RF-LAMBDA RFPFC	ASSEMBLY REVISION VS52
	ASSEMBLY NAME RFLVR07
	DRAWING NUMBER D05-A
RFPSHT0001W4 HIGH POWER PHASE SHIFTER TUNER	
www.rflambda.com	
RF-LAMBDA	SIZE LT SHEETS 1 OF 1