

HIGH POWER PHASE SHIFTER TUNER--- RFPSHT0001W9

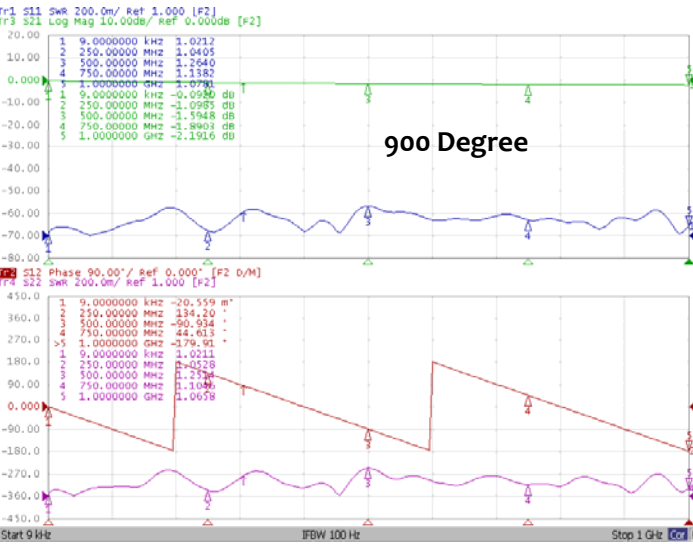

1.0 Mechanical Specifications	
1.1 Connector	SMA -Female or N-Female
1.2 Size	27.756" x 5.748" x 3.031" (705 x 146 x 77mm)
1.3 Weight	4250g
1.4 External Finish	Body painted with blue/black epoxy enamel

2.0 Environment specifications	
2.1 Operation Temp.	-10°C~+50°C
2.2 Storage Temp.	-40°C~+70°C
2.3 Altitude	45000 ft
2.4 Vibration	10g rms (15 degree 2KHz)
2.5 Humidity	100% RH at 35c, 95%RH at 40 deg c
2.6 Shock	20G for 11msc

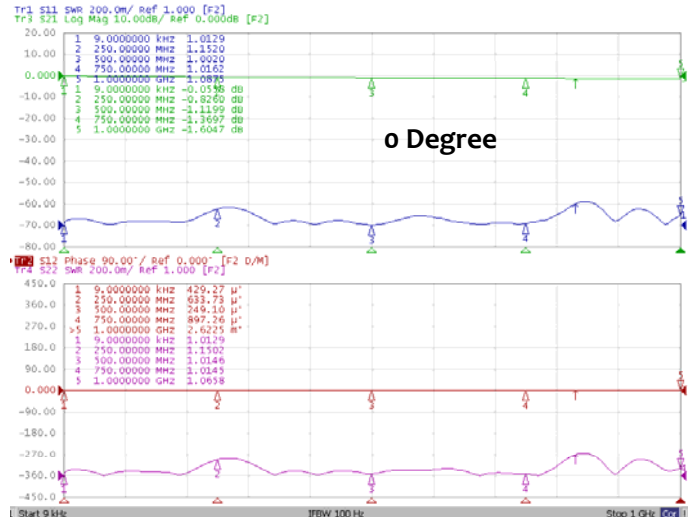
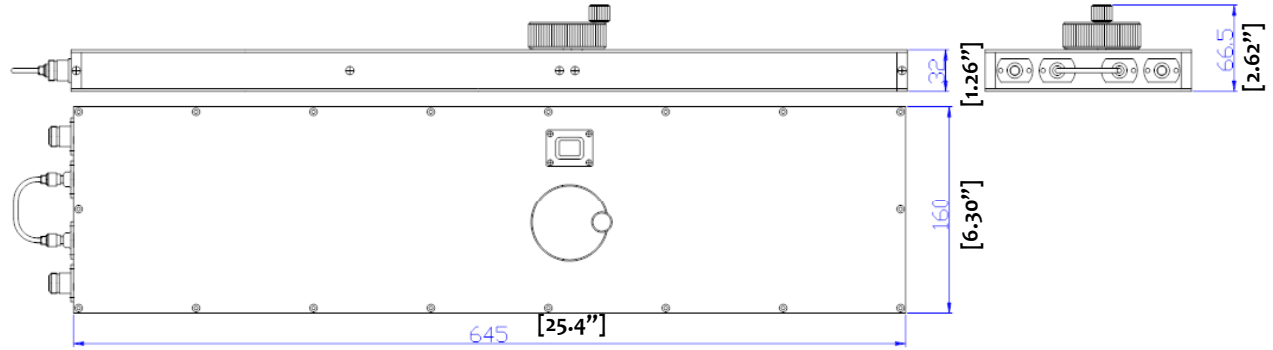

3.0 Electrical Specifications					
Part Number	Frequency (GHz)	Insertion Loss (dB)	Phase Adjustment	Max VSWR	Average / Peak Power (W)
RFPSHT0001W9	DC-1	<2.5	900° ***	1.5	100W / 5KW

***Phase Adjustment Range specification ONLY refer to the highest frequency point. Total Phase Adjustment Range is proportion of Frequency range. HALF the frequency range, HALF of the phase adjustment range. (For example 8GHz range 360°, then 4GHz will be 180° total range)

PAGE 1 OF 1	DATE Oct 8 th 2006
<small>PROPRIETARY INFORMATION THE INFORMATION CONTAINED IN THIS DOCUMENT IS THE PROPERTY OF RF-LAMBDA EXCEPT AS SPECIFICALLY AUTHORIZED IN WRITINGS BY RF-LAMBDA. THE HOLDER OF THIS DOCUMENT SHALL KEEP ALL INFORMATION CONTAINED HEREIN CONFIDENTIAL AND SHALL PROTECT SAME IN THE WHOLE OR IN PART FROM DISCLOSURE AND DISSEMINATION OF ALL THIRD PARTIES AND SHALL USE SAME FOR OPERATING AND MAINTENANCE PURPOSES ONLY</small>	DESIGN RFPC
	RF-LAMBDA RFPC
 RFPSHT0001W9 HIGH POWER PHASE SHIFTER TUNER	CAD MODEL REVISION 10
	ASSEMBLY REVISION VS52
	ASSEMBLY NAME RFLVR07
www.rflambda.com	DRAWING NUMBER D05-A
RF-LAMBDA	SIZE LT SHEETS 1 OF 1