

Helping Customers Innovate, Improve & Grow



**MX-042**

### Features

- 3us in 24 hours holdover (see profile)
- 0.5 us in 8 hours holdover
- Ultra-High Stability
- Excellent Temperature Stability
- SC-Cut Crystal
- Frequency Range: 5 MHZ to 15 MHZ
- Superior Allan Deviation 5 e-12 at 1000s

### Applications

- LTE Base Stations
- Test and Measurement Equipment
- Broadcast Reference Standard
- Military high precision references

## Performance Specifications

Parameter	Min	Typ	Max	Units	Condition
<b>Holdover</b>					
Holdover Time					
8 hours			500	ns	20 C variation per attached temperature profile
24 hours			3	μs	20 C variation per attached temperature profile
<b>Frequency Stability</b>					
vs. operating temperature range	-0.1 -0.2		+0.1 +0.2	ppb ppb	0... +70° C (referenced to +25°C) -40... +70° C (referenced to +25°C)
Initial Tolerance	-20		+20		at time of shipment, nominal EFC
vs. supply voltage change	-0.1		+0.1		VS ± 1%
vs. load change	-0.1		+0.1		Load ± 5%
vs aging/ day	-0.05		+0.05		after 7 days of operation
vs. aging / 1 year	-15		+15		after 7 days of operation
vs. aging / year (following years)	-5		+5		
vs.aging/ 5 years	-50		+50		
Warm-up Time			5	minutes	to ± 8 ppb of final frequency (1 hour) @25°C
<b>Supply Power</b>					
Supply voltage (Standard)	11.4	12.0	12.6	VDC	
Supply Voltage (Option)	4.75	5.0	5.25	VDC	EFC tuning will differ slightly @ 5 VDC
Power consumption			7.2	Watts	during warm-up
			2	Watts	steady state @ +25°C
Reference voltage	4.9	5.0	5.1	VDC	

## Performance Specifications

Parameter	Min	Typ	Max	Units	Condition
<b>RF Output</b>					
Signal [Option]	HCMOS				
Load		15		pF	
Signal Level (Vol)			0.5	VDC	with 15pF load
Signal Level (Voh)	3.5			VDC	with 15pF load
Duty cycle	45		55	%	(Voh-Vol)/2
Signal [Standard]	Sinewave				
Load		50		ohm	
Output Power	+5.0	+7.0	+9.0	dBm	with 12V supply
	+2.0	+4.0	+6.0	dBm	with 5V supply
Harmonics			-40	dBc	50 Ohm load
Sub-Harmonics			-40	dBc	50 Ohm load
<b>Frequency Tuning (EFC)</b>					
Tuning Range	±0.1	±0.15	±0.2	ppm	
Linearity			5	%	
Control Voltage Range	0	+2.5	+5.0	VDC	with 12V supply
	0	+1.65	+3.3	VDC	with 5V supply
Tuning Slope	Positive				
<b>Additional Parameters</b>					
Phase Noise @ 10 MHz			-95	dBc/Hz	1 Hz
			-125	dBc/Hz	10 Hz
			-140	dBc/Hz	100 Hz
			-145	dBc/Hz	1 KHz
			-145	dBc/Hz	>10 KHz
Short Term Stability			3	e-12	1 second tau
			5	e-12	10 second tau
			5	e-12	100 second tau
			5	e-12	1000 second tau
Weight			55	g	
Processing & Packing					Handling & processing note
<b>Absolute Maximum Ratings</b>					
Supply Voltage			15	VDC	
Output Load			50 25	pF ohm	with HCMOS signal with Sinewave signal
Operable temperature range	-55		+85	°C	
Storage temperature range	-55		+125	°C	
<b>Environmental and Product Classification</b>					
Shock (Endurance)	MIL-STD-202, Method 213, Condition J, 30 g 11 ms				
Sine Vibration (Endurance)	MIL-STD-202, Method 201 and 204, Condition A, except 5 g to 500 Hz, 1 sweep each axis				
Random Vibration (Endurance)	MIL-STD-202, Method 214, Condition I-D				
Humidity	MIL-STD-202, Method 103, Condition B, 100% rh				
Altitude	MIL-STD-202, Method 105, sea level to space				
Resistance to Soldering Heat	MIL-STD-202, Method 210, Condition A,B,C				
Terminal Strength	MIL-STD-202, Method 11, Condition C (5 bends at 45°, 2 lbs)				
Moisture Sensitive Level	1				
RoHS	6 (fully compliant) - no pure tin options available upon request, the device will be assigned a customer part number, not orderable through ordering codes				

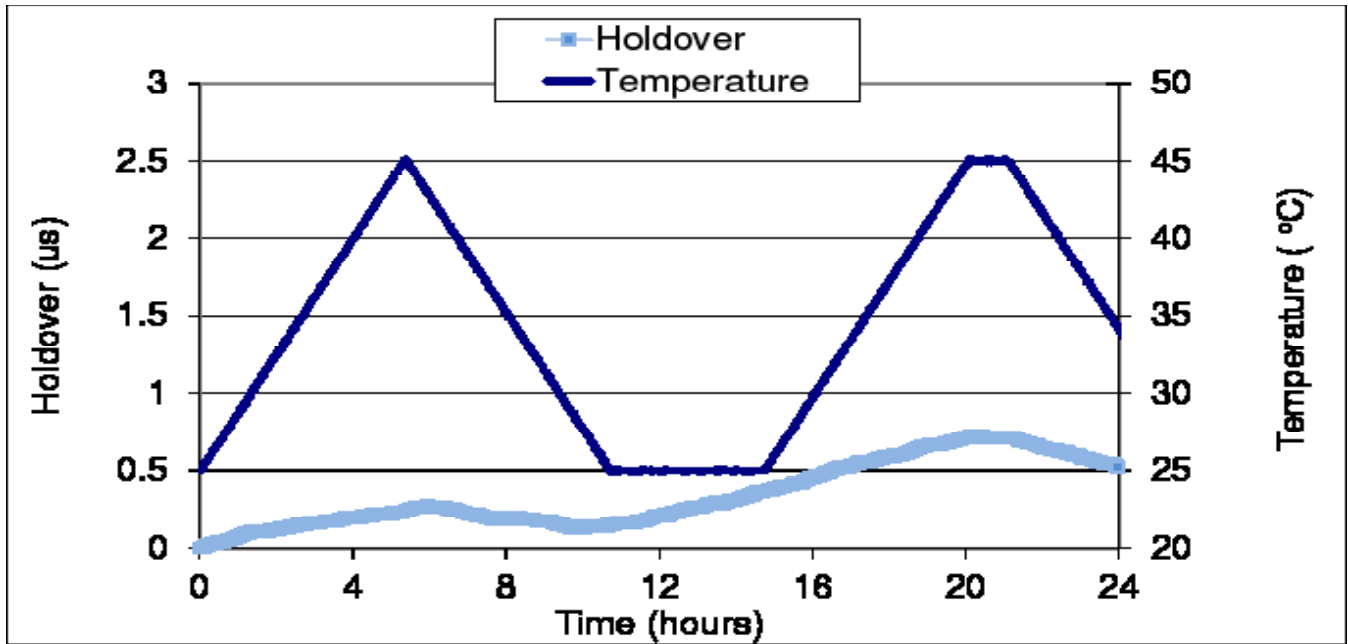

Date: 09/07/10 Time: 09:29:50 Data Points: 14847 of 14847 File: 000000000000 File: sn16longsts.002

# FREQUENCY STABILITY

sn16longsts.002

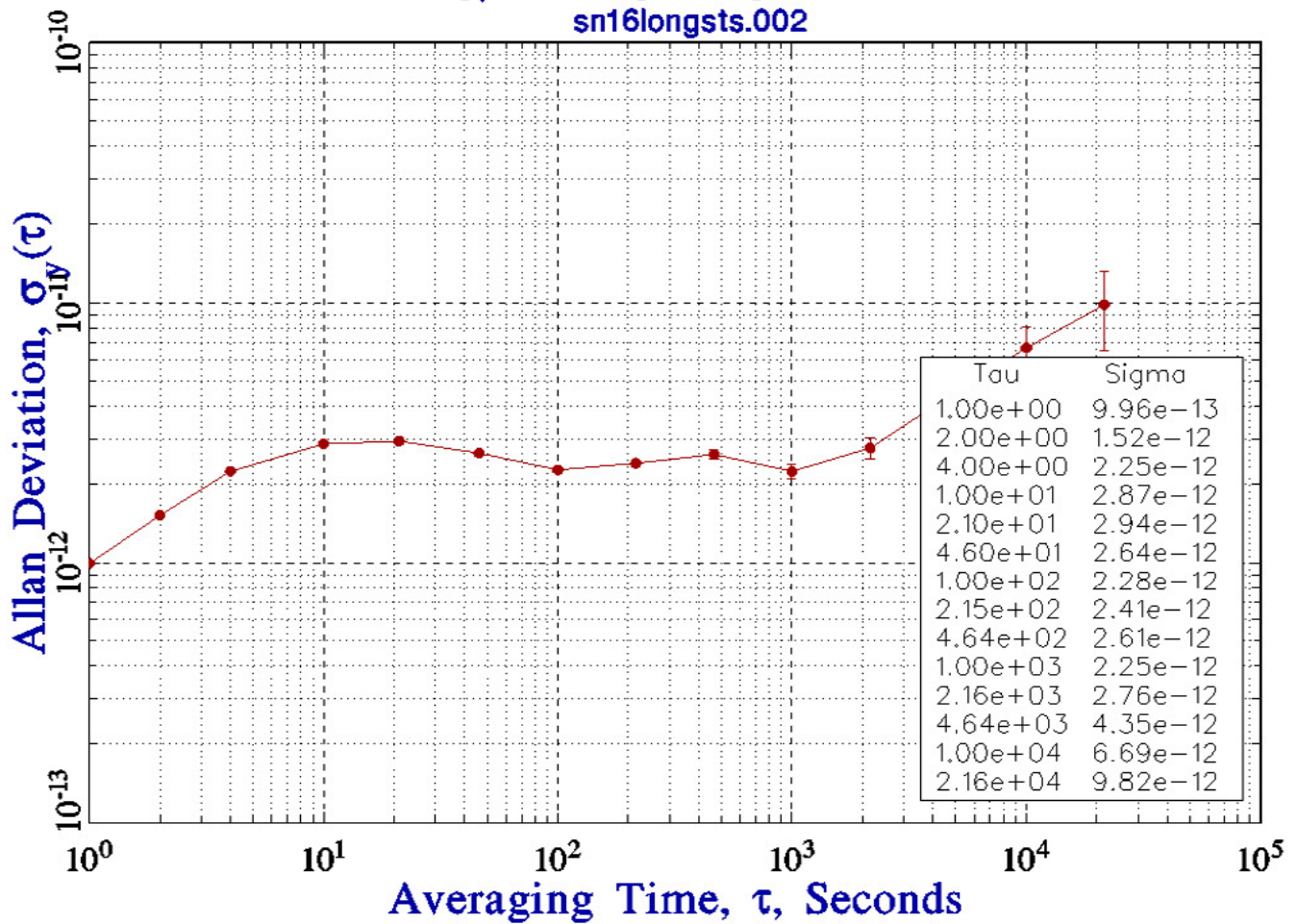

# Outline Drawing / Enclosure

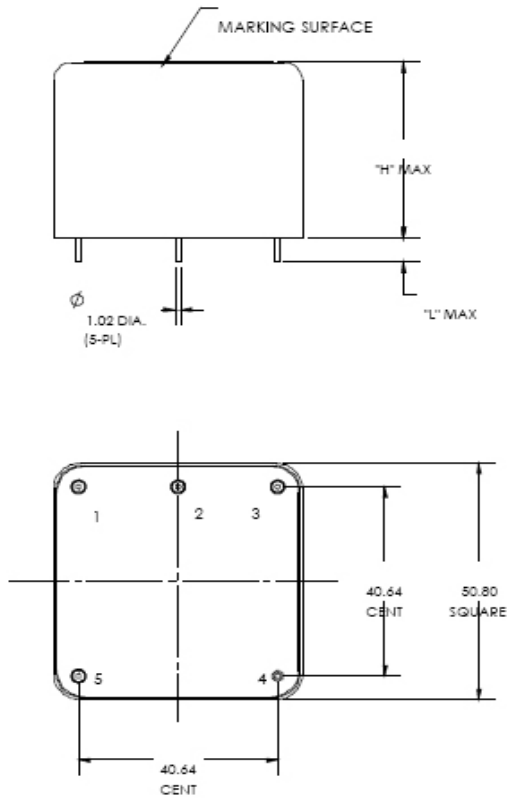

Dimensions in mm

Type A		
Code	Height "H"	Pin Length "L"
0	25.4	6.35

Pin Connections	
1	Electronic Frequency Control (EFC)
2	Reference Voltage Output
3	RF Output
4	Ground (Case)
5	Supply Voltage Input (Vs)

## Ordering Information

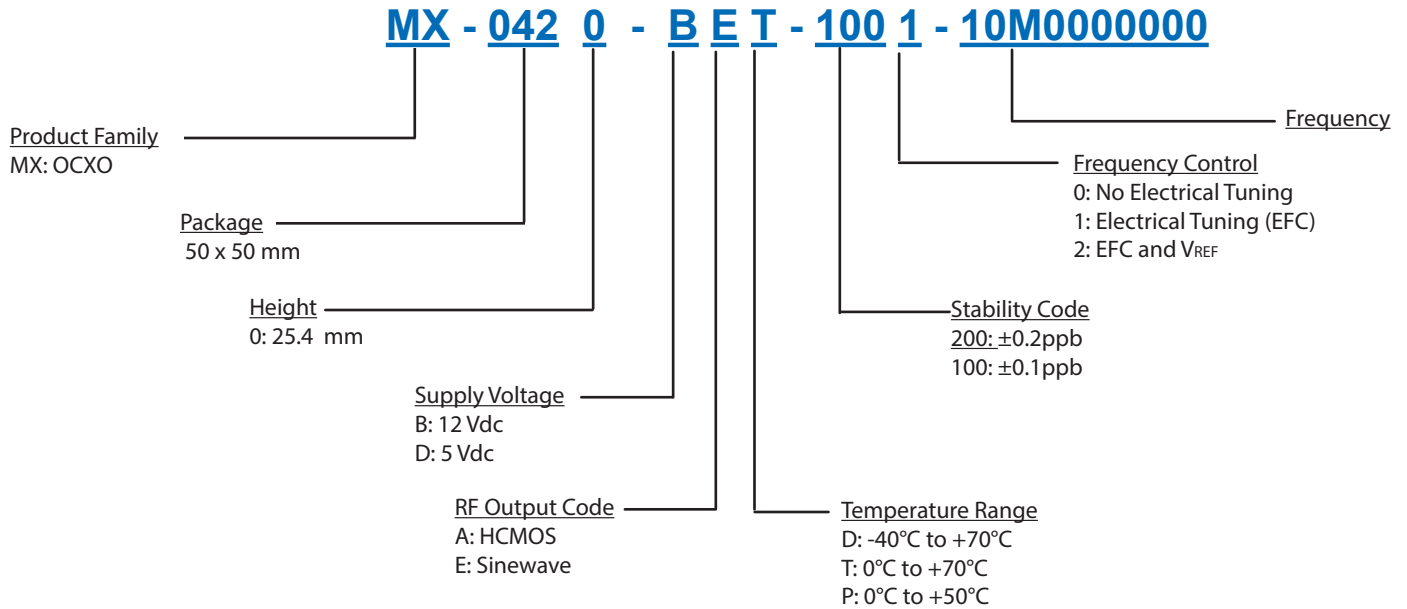

**Notes:**

1. Contact factory for improved stabilities or additional product options.
2. Unless otherwise stated, all values are valid after warm-up time and refer to typical conditions for supply voltage, frequency control voltage, load, and temperature (25°C).
3. Phase noise degrades with increasing output frequency.
4. Subject to technical modification.
5. Contact factory for availability.

## For Additional Information, Please Contact

**USA:**

Vectron International  
267 Lowell Road, Suite 102  
Hudson, NH 03051  
Tel: 1.888.328.7661  
Fax: 1.888.329.8328

**Europe:**

Vectron International  
Landstrasse, D-74924  
Neckarbischofsheim, Germany  
Tel: +49 (0) 3328.4784.17  
Fax: +49 (0) 3328.4784.30

**Asia:**

Vectron International  
68 Yin Cheng Road(C), 22nd Floor  
One LuJiaZui  
Pudong, Shanghai 200120, China  
Tel: +86 21 6194 6886  
Fax: +86 21 6194 6699

**Disclaimer**

Vectron International reserves the right to make changes to the product(s) and or information contained herein without notice. No liability is assumed as a result of their use or application. No rights under any patent accompany the sale of any such product(s) or information.

Rev: 10-20-14 jar