

# ULTRA PRECISION OCXO MV62

## Features:

- High stability vs. temperature - up to  $\pm 5 \times 10^{-10}$
- Low aging – up to  $\pm 2 \times 10^{-8}$ /year
- Low phase noise
- Option with package height of 19mm (3/4")
- Ideal for GPS, CDMA, 3G applications
- Frequency range 5.0-10.0 MHz
- Available as RoHS

Package type	
Y	51.3x41.3x25 mm
Y19	51.3x41.3x19 mm

Output type
SIN
HCMOS

## ORDERING GUIDE: MV62 – C 05 F – Y – SIN – 10.0 MHz

Availability of certain stability vs. operating temperature range		$\pm 5 \times 10^{-9}$	$\pm 2 \times 10^{-9}$	$\pm 1 \times 10^{-9}$	$\pm 5 \times 10^{-10}$
		5	2	1	05
A	0...+55 °C	A	A	A	A
B	-10...+60 °C	A	A	A	A
C	-20...+70 °C	A	A	A	A
D	-40...+70 °C	A	A	A	C

For other temperature ranges see designation at the end of Data Sheet

## Package drawing:

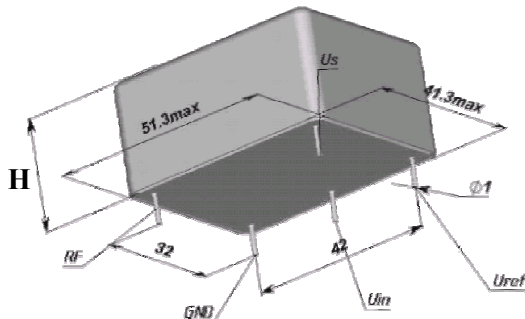

H=25 mm for Y; H=19 mm for Y19.

Availability of certain aging values for certain frequencies		Standard frequencies		
		5.0 MHz	8.192 MHz	10.0 MHz
F	$\pm 5 \times 10^{-8}$ /year	A	A	A
E	$\pm 3 \times 10^{-8}$ /year	A	A	A
D	$\pm 2 \times 10^{-8}$ /year	A	C	NA

A – available, NA – not available, C – consult factory

Short term stability (Allan deviation) per 1 sec	$< 5 \times 10^{-12}$
Frequency stability vs. load changes	$< \pm 3 \times 10^{-10}$
Frequency stability vs. power supply changes	$< \pm 3 \times 10^{-10}$
Power supply	12V $\pm$ 5%
Steady state current consumption @ 25°C	< 180 mA
Peak current consumption after switch-on	< 500 mA
Warm-up time within $< \pm 5 \times 10^{-8}$	< 5 min
Frequency pulling range	$> \pm 3 \times 10^{-7}$
with external voltage range	0...+5 V
with external potentiometer	20 kOhm
Reference voltage output	+5 V
Slope	Positive

Output	SIN	HCMOS
Level (see also notes)	>225 mV (0dBm)	5V/ 45...55%
Load	50 Ohm $\pm$ 5%	10kOhm/15pF
Harmonic suppression	>30dB	-
Phase noise, typical (for 10 MHz) @ 1 Hz	-100 dBc/Hz	-97 dBc/Hz
10 Hz	-125 dBc/Hz	-122 dBc/Hz
100 Hz	-145 dBc/Hz	-142 dBc/Hz
1000 Hz	-150 dBc/Hz	-147 dBc/Hz
10000 Hz	-155 dBc/Hz	-150 dBc/Hz

## Additional notes:

- Option with output level of >1000 mV for SIN output.
- Showed values of frequency stability vs. temperature usually are tested in Still Air test conditions. Please inform factory about different conditions in operation to provide appropriate tests.
- Please consult factory for daily aging values. Normally typical correspondence of daily aging per day to aging per year is as following:  $\pm 5 \times 10^{-8}$ /year -  $\pm 5 \times 10^{-10}$ /day;  $\pm 3 \times 10^{-8}$ /year -  $\pm 3 \times 10^{-10}$ /day;  $\pm 2 \times 10^{-8}$ /year -  $\pm 2 \times 10^{-10}$ /day.
- Please mention RoHS requirement (if any) while requesting for quote or while placing PO.
- For non standard operating temperature ranges please use the following two letters designations (first letter for the lower limit, second letter for the upper limit), °C:

A	B	C	D	E	F	G	H	J	K	L	M	N	P	Q	R	S	T	U	W	X
-60	-55	-50	-45	-40	-30	-20	-10	0	+10	+30	+40	+45	+50	+55	+60	+65	+70	+75	+80	+85

## Mechanical characteristics:

Vibrations:	
Frequency range	1...200 Hz
Acceleration	5 g
Shock:	
Acceleration	100 g
Duration	3.0 ms
Storage temperature range	-55...+85 °C