



150W o. 8-2.5GHz Slabline 90° Hybrid



Summary:

- . High power operational up to 150W CW
- . Small compacted package
- . Wide bandwidth, flat frequency response
- . MIL-E-5400 standard

Electrical and Environmental Specifications:

Frequency Range:	0.8-2.5GHz
Insertion Loss:	0.30dB
Isolation:	22dB
Amplitude Unbalance:	± 0.5dB
Phase unbalance:	± 4.0 degree
Power:	150W CW
VSWR:	1.20 : 1
Operational Temp. Range:	-20°C~+70° C
Storage Temp. Range:	-40°C~+70° C

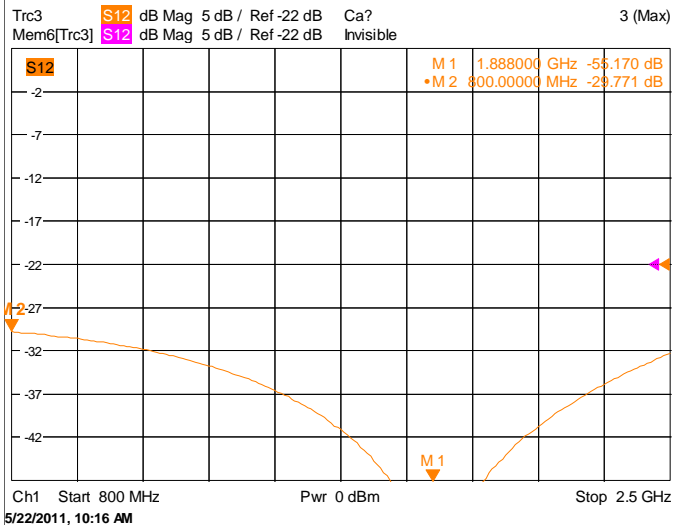
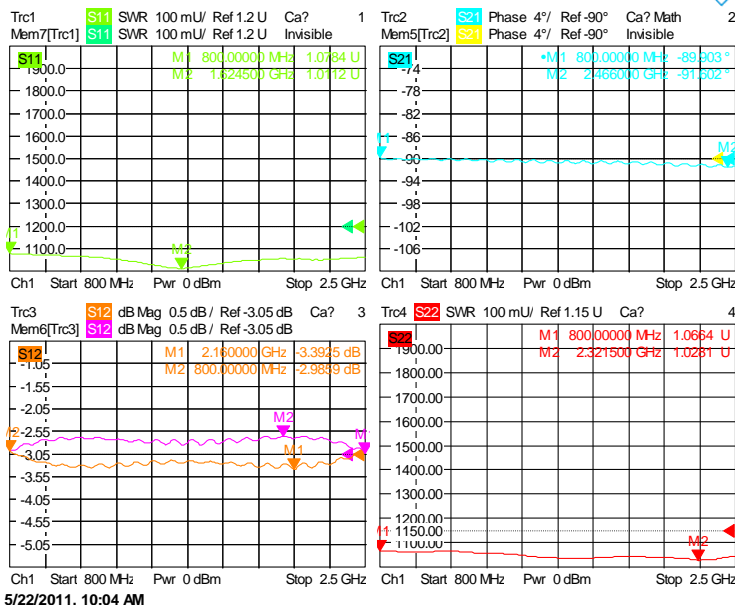
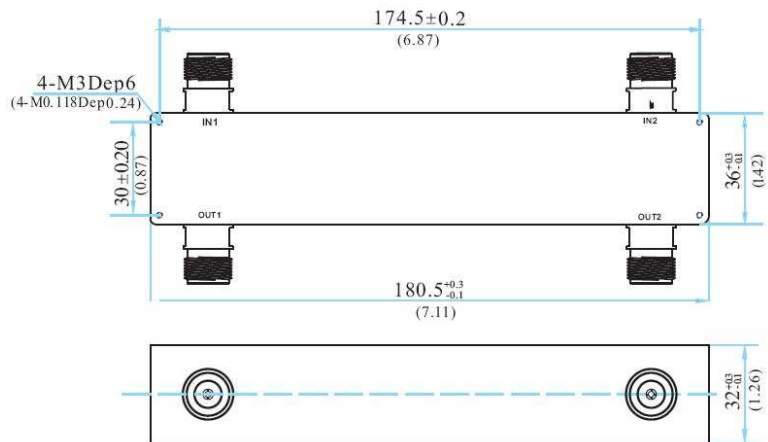

Coaxial 150W o. 8-2.5GHz Slabline 90° Hybrid