

# Ceramic Low Pass Filter

## LFCN-3800D+

50Ω DC to 3900 MHz



CASE STYLE: FV1206  
PRICE: \$3.49 ea. QTY (20)

**+RoHS Compliant**

The +Suffix identifies RoHS Compliance. See our web site for RoHS Compliance methodologies and qualifications



Available Tape and Reel at no extra cost

Reel Size	Devices/Reel
7"	20, 50, 100, 200, 500, 1000, 3000

### Maximum Ratings

Operating Temperature	-55°C to 100°C
Storage Temperature	-55°C to 100°C
RF Power Input*	8W max. at 25°C
Max. DC Voltage at pins 1 & 3	25 VDC
DC Current Input to Output	0.5A max. at 25°C

\* Passband rating, derate linearly to 3W at 100°C ambient. Permanent damage may occur if any of these limits are exceeded.

### Pin Connections

RF IN	1
RF OUT	3
GROUND	2,4

### Outline Drawing

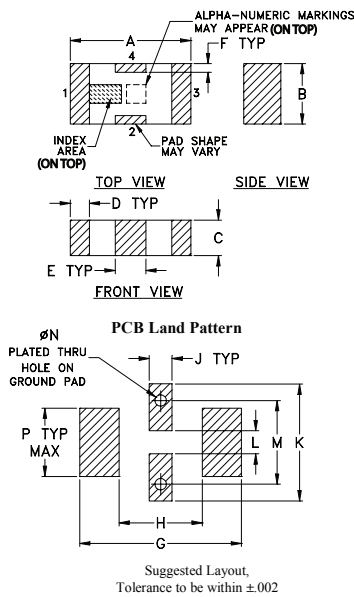

### Outline Dimensions (inch)

mm						
A	B	C	D	E	F	G
.126	.063	.037	.020	.032	.009	.169
3.20	1.60	0.94	0.51	0.81	0.23	4.29
H	J	K	L	M	N	P
.087	.024	.122	.024	.087	.012	.071
2.21	0.61	3.10	0.61	2.21	0.30	1.80
						wt
						grams
						.020

Demo Board MCL P/N: TB-270  
Suggested PCB Layout (PL-137)

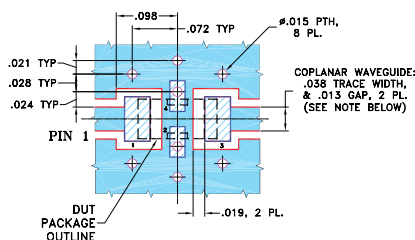

NOTES: 1. COPLANAR WAVEGUIDE PARAMETERS ARE SHOWN FOR ROGERS RO4350B WITH THICKNESS .020" ± .0015". COPPER: 1/2 OZ. EACH SIDE. FOR OTHER MATERIALS TRACE WIDTH & GAP MAY NEED TO BE MODIFIED.

2. BOTTOM SIDE OF THE PCB IS CONTINUOUS GROUND PLANE. DENOTES PCB COPPER LAYOUT WITH SMOBC (SOLDER MASK OVER BARE COPPER)

3. DENOTES COPPER LAND PATTERN FREE OF SOLDER MASK

A. Performance and quality attributes and conditions not expressly stated in this specification document are intended to be excluded and do not form a part of this specification document.

B. Electrical specifications and performance data contained in this specification document are based on Mini-Circuit's applicable established test performance criteria and measurement instructions.

C. The parts covered by this specification document are subject to Mini-Circuits standard limited warranty and terms and conditions (collectively, "Standard Terms"); Purchasers of this part are entitled to the rights and benefits contained therein. For a full statement of the Standard Terms and the exclusive rights and remedies thereunder, please visit Mini-Circuits' website at [www.minicircuits.com/MCLStore/terms.jsp](http://www.minicircuits.com/MCLStore/terms.jsp)

### Features

- excellent power handling, 8W
- small size
- 7 sections
- temperature stable
- hermetically sealed
- LTCC construction
- protected by U.S. Patent 6,943,646

### Applications

- harmonic rejection
- VHF/UHF transmitters/receivers
- lab use

### Electrical Specifications<sup>1,2</sup> at 25°C

Parameter	F#	Frequency (MHz)	Min.	Typ.	Max.	Unit	
Pass Band	Insertion Loss	DC-F1	DC-3900	—	—	1.5	dB
	Freq. Cut-Off	F2	4850	—	3.0	—	dB
	VSWR	DC-F1	DC-3900	—	1.3	—	:1
Stop Band	Rejection Loss	F3	6000	20	—	—	dB
		F4-F5	5700-8300	—	30	—	dB
	VSWR	F5-F6	8300-13000	—	20	—	dB
		F3-F6	6000-13000	—	17	—	:1

1. DC Resistance to ground is 100 Mohms min.

2. Measured on Mini-Circuits Characterization Test Board TB-270.

### Typical Frequency Response

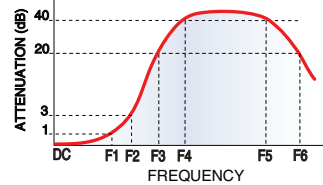

### Electrical Schematic

### Typical Performance Data at 25°C

Frequency (MHz)	Insertion Loss (dB)	VSWR (:1)
40	0.06	1.03
1550	0.27	1.07
3060	0.48	1.25
3900	0.66	1.34
4510	0.95	1.11
4760	1.93	1.95
4850	2.76	2.60
4930	3.84	3.48
5120	7.65	7.05
5380	15.30	14.15
5700	30.21	20.22
6000	33.71	23.49
8300	29.24	19.76
13000	18.04	12.09
20000	14.19	6.35

### LFCN-3800D+ INSERTION LOSS

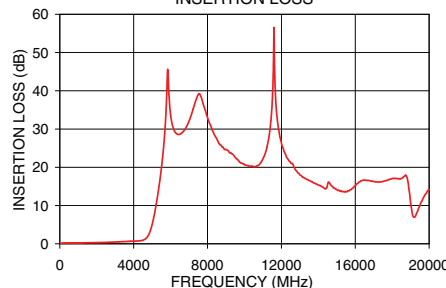

### LFCN-3800D+ VSWR

