



# RF-LAMBDA

The power beyond expectations

## RKT2G2A101

### ROTARY KNOB MANUAL CONTROL STEP ATTENUATOR (DC-2GHz 101DB RANGE)

#### Product description

- Very small package and broadband performance
- Continuous variable attenuation during operation
- Excellent Repeatability and Long Life Switch
- Low Deviation from Nominal Value
- 50Ω impedance standard upon request
- 2W CW average power upon request
- Custom Configurations Available Upon Request.



#### Applications:

Include Communication, 3G, Digital Transmission, Radar, Military, Broadcast & Television, science & Research department etc.

Part Number	Frequency	Power (Watts)	Attenuation Range (dB)	Attenuation Step (dB)	VSWR max.	Insertion Loss (dB)	Accuracy (dB)
RKT2G2A101	DC-2GHz	2	101	0.1	1.50	≤1.2	± 0.2dB(0.1~1dB) ± 0.4dB(1~10dB) ± 0.8dB(10~60dB) ± 1.5dB(<70dB) ± 4%[≥70dB]

Connector: N type, weight: 1250g

Temperature

(Operational): -10° C~+50° C

(Storage) -40° C~+70° C

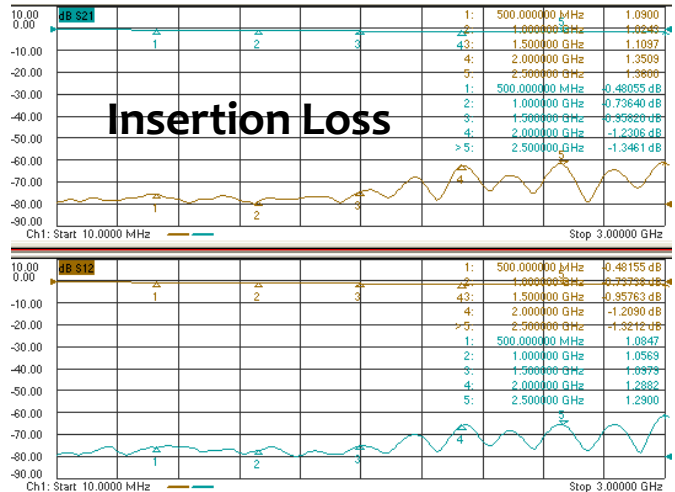
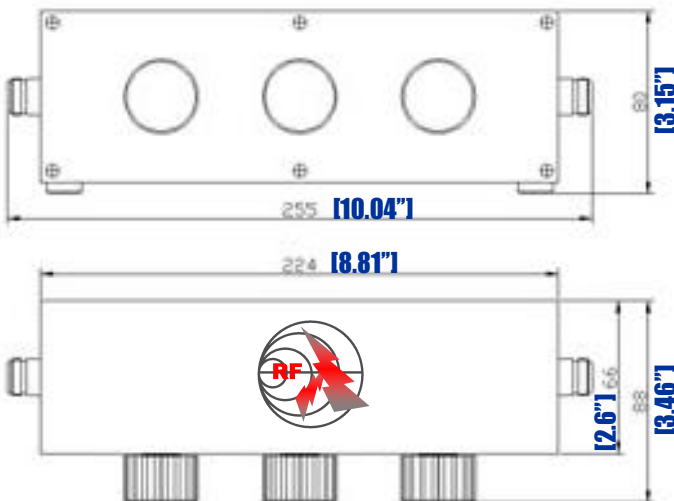

PN: **RKT 2 G X A 101**

Manual Control Handle Attenuator    Power In Watt    Freq Unit GHz    Freq Number    Product Type    Attenuation Range

MANUAL CONTROL STEP ATTENUATOR (DC-2GHz 101DB RANGE)



# RF-LAMBDA

The power beyond expectations

## RKT2G2A101

### 19" X 2U RACK MOUNTING PACKAGE AVAILABLE

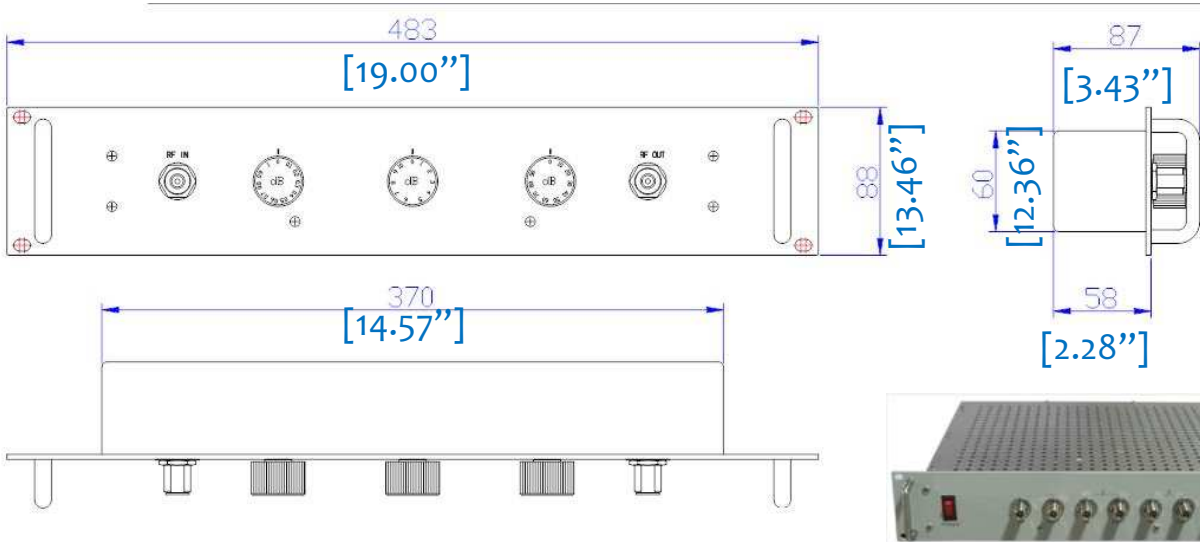

MANUAL CONTROL STEP ATTENUATOR (DC-2GHz 101DB RANGE)

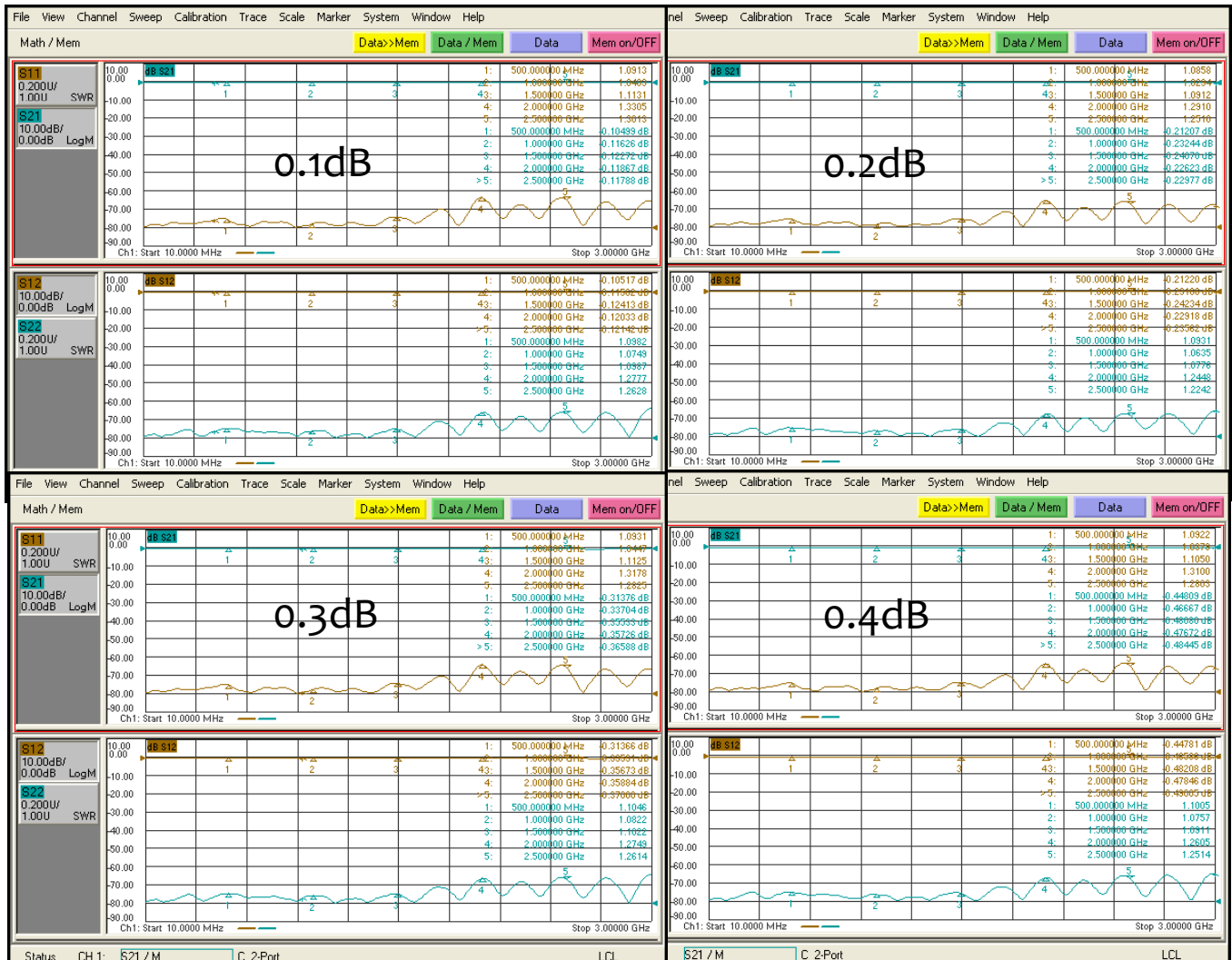



# RF-LAMBDA

The power beyond expectations

## RKT2G2A101

MANUAL CONTROL STEP ATTENUATOR (DC-2GHz 101DB RANGE)

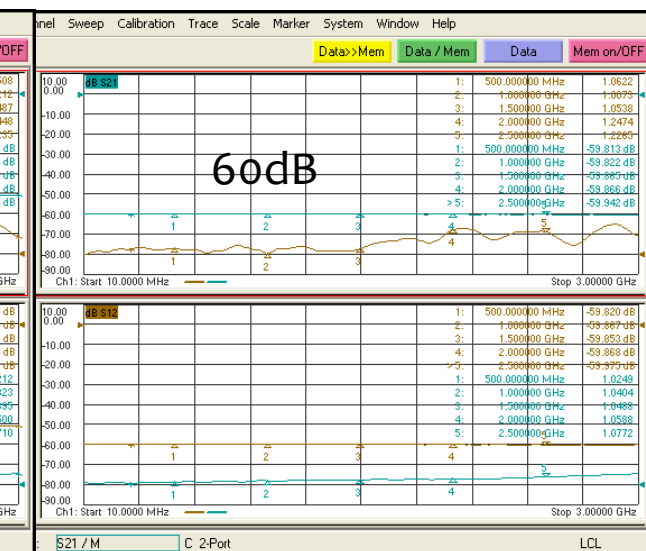
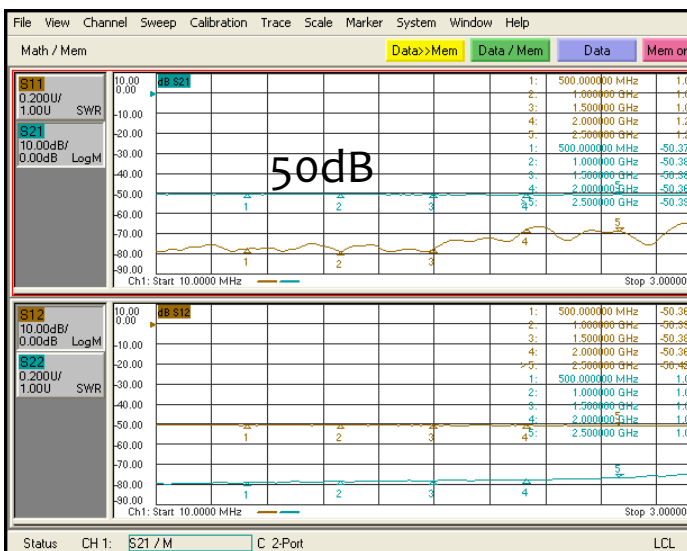
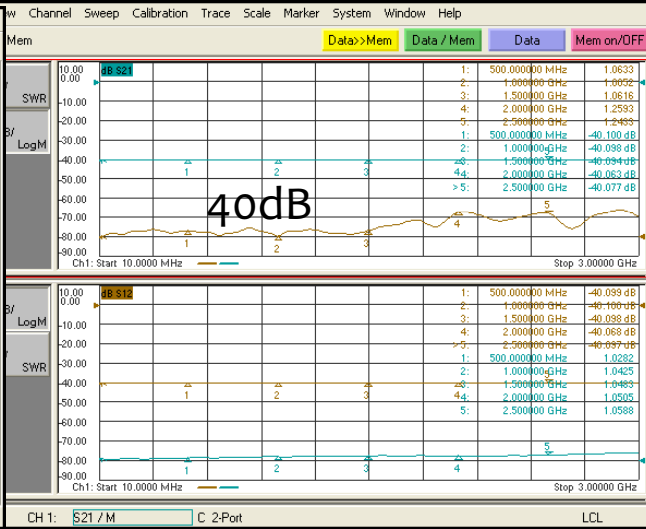
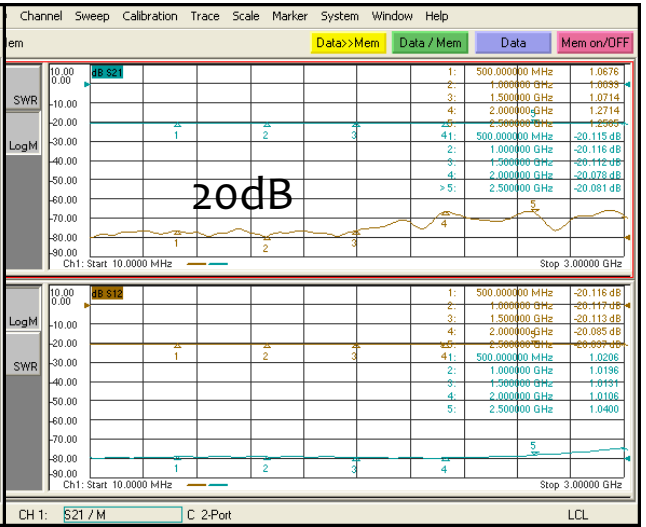
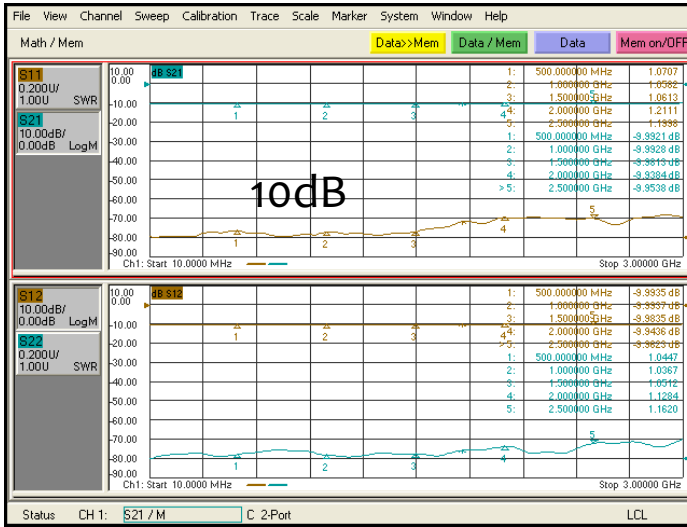



# RF-LAMBDA

The power beyond expectations

## RKT2G2A101

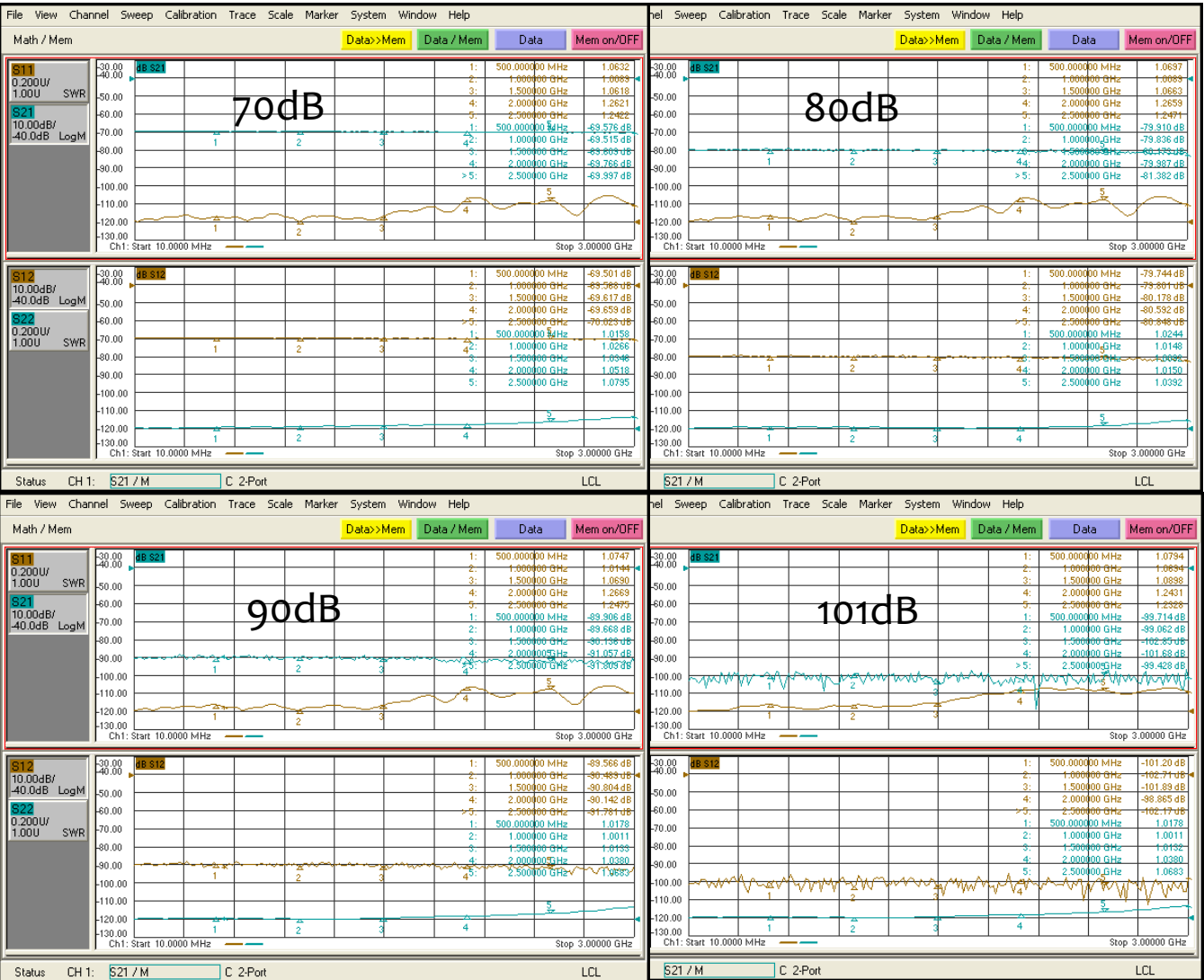

MANUAL CONTROL STEP ATTENUATOR (DC-2GHz 101DB RANGE)