

SF2089C

**327.5 MHz
SAW Filter**

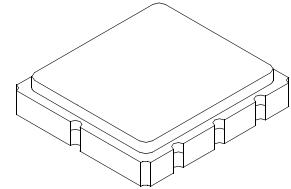

SM5050-8

- **Low Insertion Loss**
- **5.0 X 5.0 mm Surface-mount Case**
- **Single-ended Input and Output**
- **Complies with Directive 2002/95/EC (RoHS)**



Absolute Maximum Ratings

Rating	Value	Units
Maximum Incident Power in Passband	+13	dBm
Maximum DC Voltage on any Non-ground Terminal	30	VDC
Storage Temperature Range in Tape and Reel	-40 to +85	°C
Suitable for Lead-free Soldering - Maximum Soldering Temperature	260 °C for 30 s	

Electrical Characteristics

Characteristic	Sym	Notes	Min	Typ	Max	Units
Center Frequency	f_c	1		327.5		MHz
Insertion Loss		1			12	dB
1.5 dB Bandwidth	$BW_{1.5}$	1	35			MHz
Amplitude Ripple, $f_c \pm 17.5$ MHz, within adjacent 5 MHz windows		1			1	dB _{p-p}
Group Delay Deviation, $f_c \pm 17.5$ MHz, within adjacent 5 MHz windows		1			50	nS _{p-p}
Group Delay Deviation, $f_c \pm 17.5$ MHz, full bandwidth		1		50	100	nS _{p-p}
VSWR at f_c		1			2.5:1	
40 dB Rejection Bandwidth		1, 2			65	MHz
Operating Temperature Range			-40		85	°C
Case Style			SM5050-8 5 x 5 mm Nominal Footprint			
Lid Symbolization (Y=year, WW=week, S=shift)			RFM 591 YWWS			

Electrical Connections

Connection		Terminals
Port 1	Input	1
Port 2	Output	5
	Ground	All others
Dot indicates Pin 1		



CAUTION: Electrostatic Sensitive Device. Observe precautions for handling.

NOTES:

1. Unless noted otherwise, all specifications apply over the operating temperature range with filter soldered to the specified demonstration board with impedance matching to 50 Ω and measured with 50 Ω network analyzer.
2. Rejection is measured as attenuation below the minimum IL point in the passband. Rejection in final user application is dependent on PCB layout and external impedance matching design. See Application Note No. 42 for details.
3. The design, manufacturing process, and specifications of this filter are subject to change.
4. Tape and Reel Standard ANSI / EIA 481.
5. Either Port 1 or Port 2 may be used for either input or output in the design. However, impedances and impedance matching may vary between Port 1 and Port 2, so that the filter must always be installed in one direction per the circuit design.
6. US and international patents may apply.
7. Murata, stylized Murata logo, and Murata N.A., Inc. are registered trademarks of Murata Manufacturing Co., Ltd.

18 Nov 2005 15:21:41

CH1 S11 1 UFS
 1: 0.0000 Ω 0.0000 Ω 0.0000 H
 0.000 000 MHz

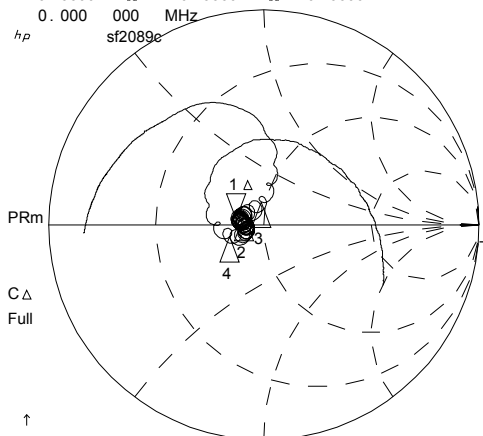

CH1 Markers
 Δ REF=1
 2: 3.0195 Ω
 1.6621 Ω
 282.553 kHz
 3: 9.3320 Ω
 8.3770 Ω
 -19.5794 MHz
 4: -2.2051 Ω
 -6.1328 Ω
 20.1445 MHz

CH3 S22 1 UFS
 1: 0.0000 Ω 0.0000 Ω 0.0000 H
 0.000 000 MHz

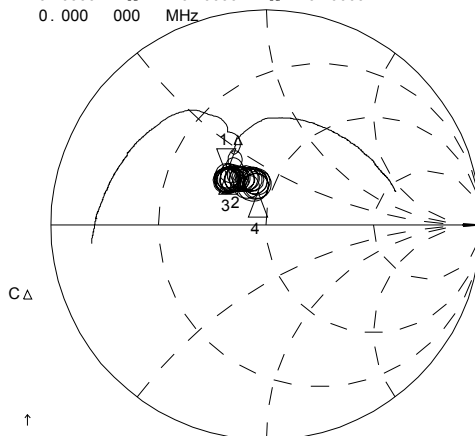

CH3 Markers
 Δ REF=1
 2: 2.5342 Ω
 4.0986 Ω
 282.553 kHz
 3: 70.313 mΩ
 1.7891 Ω
 -19.5794 MHz
 4: 13.325 Ω
 -2.1670 Ω
 20.1445 MHz

↑
 CENTR 327.500 MHz SPAN 100.000 MHz

↑
 CENTR 327.500 MHz SPAN 100.000 MHz

CH2 S21 LOG 10 dB/ REF -12 dB 1: 0.0000 dB 0.000 000 MHz

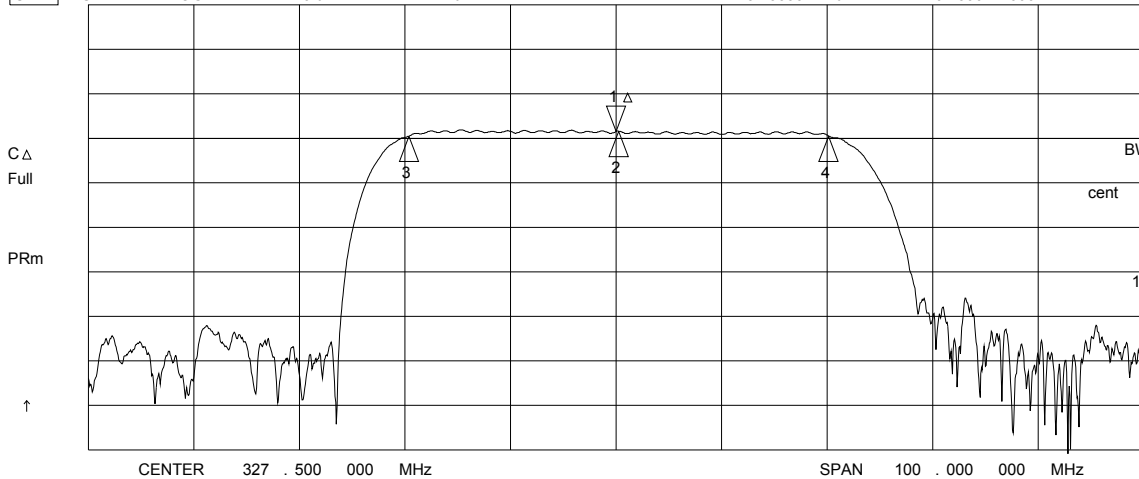

CH2 Markers
 Δ REF=1
 BW: 39.723986 MHz
 cent: 327.782553 MHz
 Q: 8.2515
 1_loss: -10.490 dB

CENTER 327.500 000 MHz

SPAN 100.000 000 MHz

18 Nov 2005 15:16:08

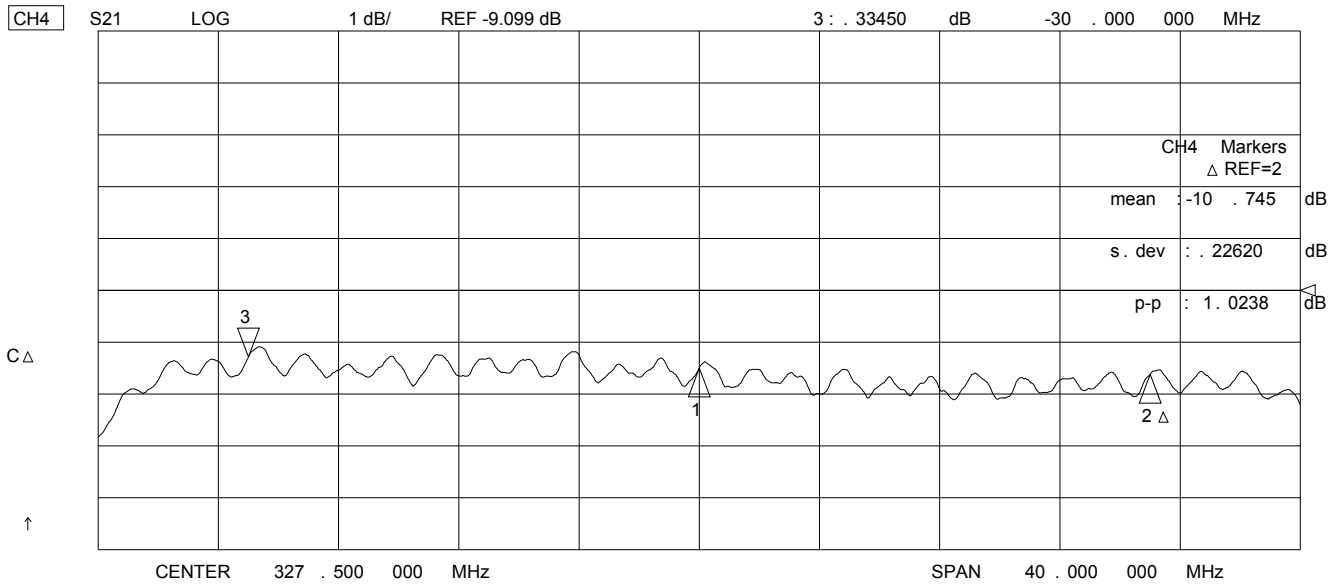
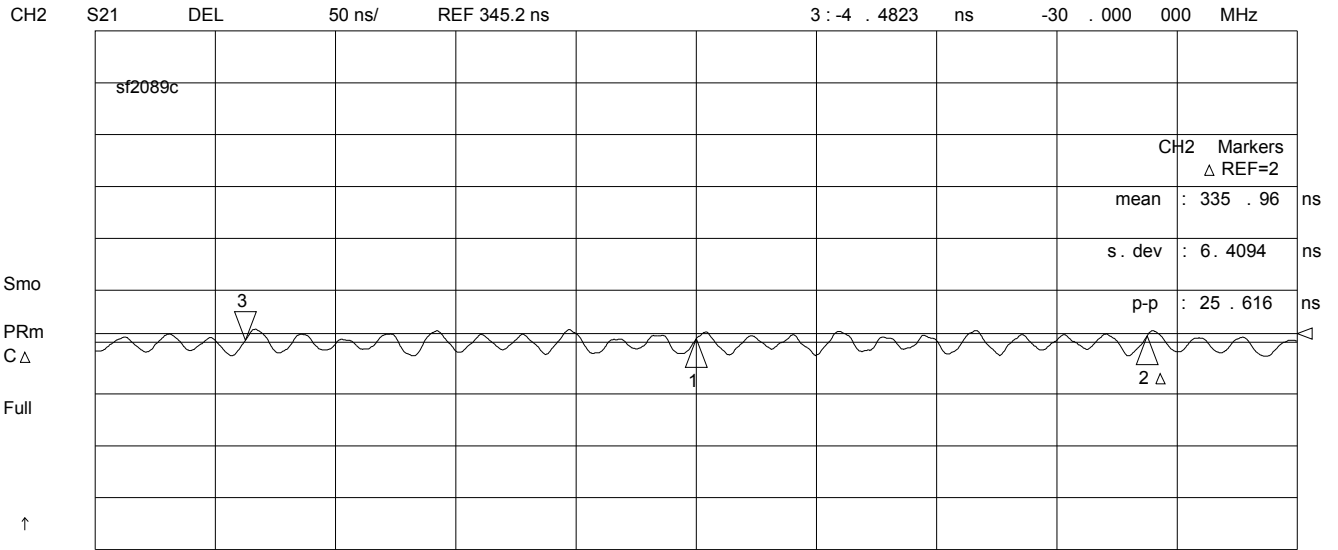

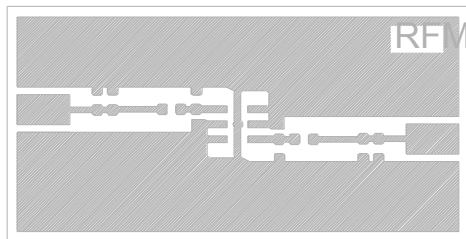
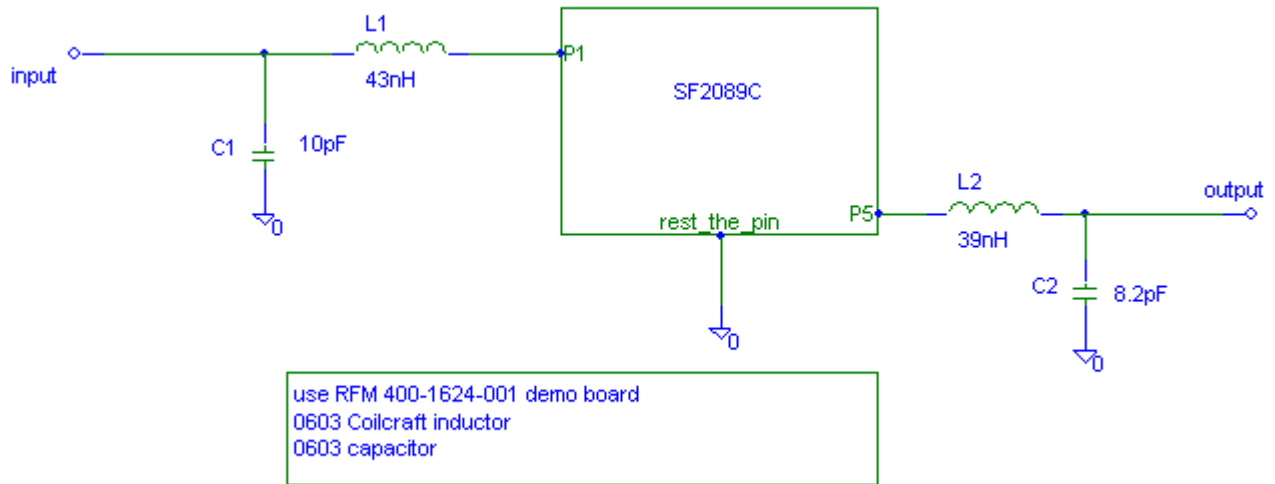

1.590 REF.

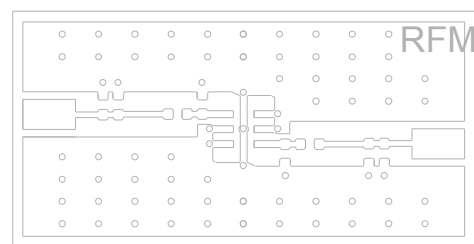
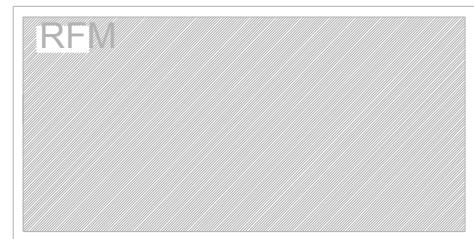

DRILL ALL HOLES #76 DRILL (0.020)
ALL HOLES ARE PLATED THRU.

SM5050-8 Surface-Mount 8-Terminal Ceramic Case 5.0 X 5.0 mm Nominal Footprint

Case Dimensions

Dimension	mm			Inches		
	Min	Nom	Max	Min	Nom	Max
A	4.80	5.00	5.20	0.189	0.197	0.205
B	4.80	5.00	5.20	0.189	0.197	0.205
C	1.30	1.50	1.70	0.050	0.060	0.067
D	1.98	2.08	2.18	0.078	0.082	0.086
E	1.07	1.17	1.27	0.042	0.046	0.050
F	0.50	0.64	0.70	0.020	0.025	0.028
G	2.39	2.54	2.69	0.094	0.100	0.106
H		1.27			0.050	
I		0.76			0.030	
J		1.55			0.061	
K		2.79			0.110	
L		0.76			0.030	
M		2.36			0.093	
N		1.55			0.061	
O		2.79			0.110	
P		2.79			0.110	
Q		2.79			0.110	

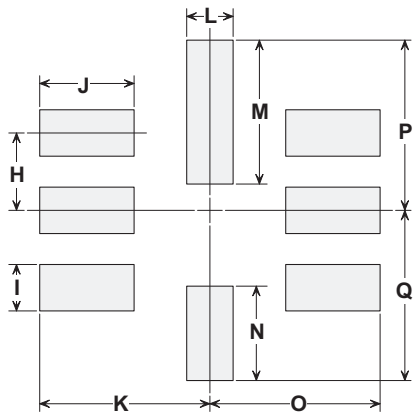
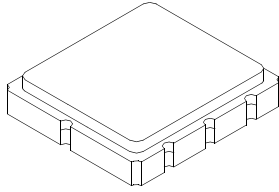

PCB Footprint

Case Materials

Materials	
Solder Pad Plating	0.3 to 1.0 μm Gold over 1.27 to 8.89 μm Nickel
Lid Plating	2.0 to 3.0 μm Nickel
Body	Al_2O_3 Ceramic
	Pb Free

TOP VIEW

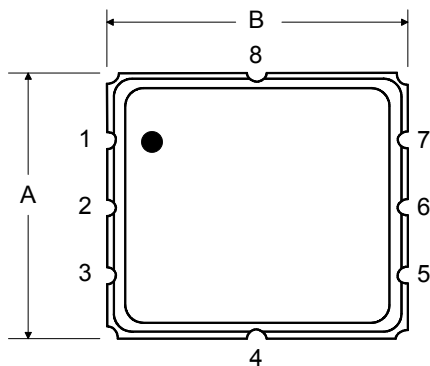

BOTTOM VIEW

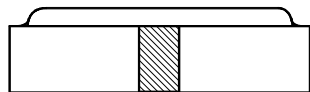
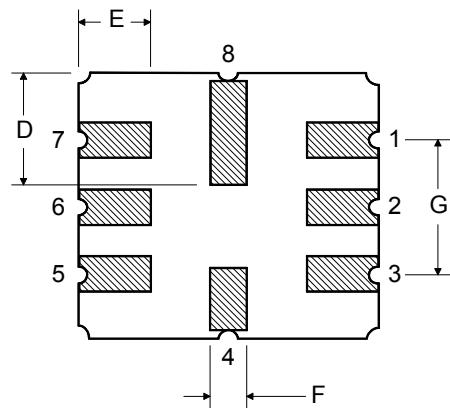

Tape and Reel Specifications

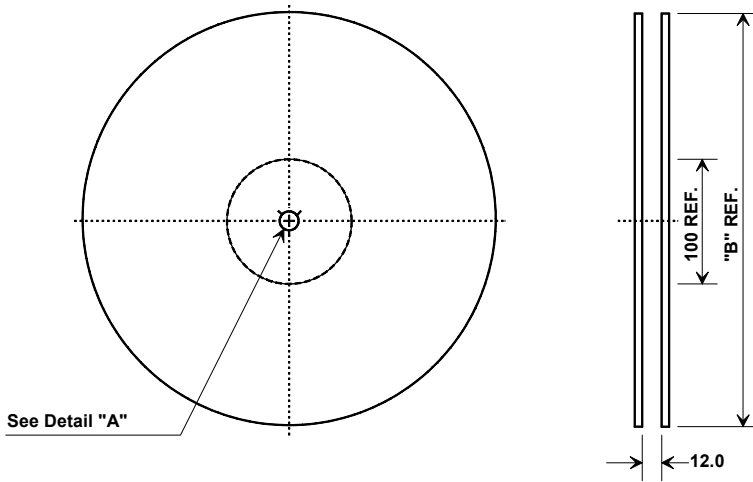

"B" Nominal Size		Quantity Per Reel
Inches	millimeters	
7	178	500
13	330	3000

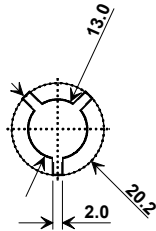

COMPONENT ORIENTATION and DIMENSIONS

Carrier Tape Dimensions	
Ao	5.3 mm
Bo	5.3 mm
Ko	2.0 mm
Pitch	8.0 mm
W	12.0 mm

