

O-MFA-1108 – I/Q PHASE DETECTOR

TECHNICAL FEATURE

FEATURES

- Selectable IF Bandwidth Filters
- BIT Functions
- IF Gain Control
- Analog I/Q Outputs
- Internal Power Conditioning/
- Switching Power Supply
- Variable Gain

PERFORMANCE

Frequency Range	55-65 MHz
Input Signal Level.....	-70 to 0 dBm
LO Frequency Range	60 +/-0.1MHz
Gain	15 dB min..
Noise Figure	10 dB max.
Phase Balance	+/-1.5° max.
Amplitude Balance	+/-0.2 dB max
Bandwidths (selectable)	0.6/0.95 MHz
Size	8.3" x 3.8" x 0.9"
Operating Temperature Range	-25 to +85 °C

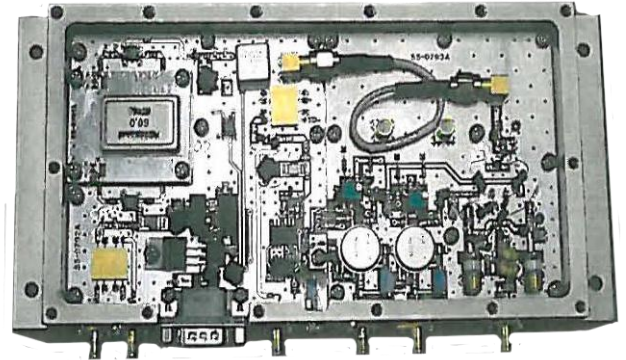

DESCRIPTION

This I/O phase detector provides analog I/O voltage signals for a comparison of 2 IF signals operating at 60 MHz. A selectable IF bandwidth is utilized to improve measurement signal to noise ratio and measurement sensitivity.

Applications include radar and EW system coherent conversion. Input signal phase and amplitude information is presented.

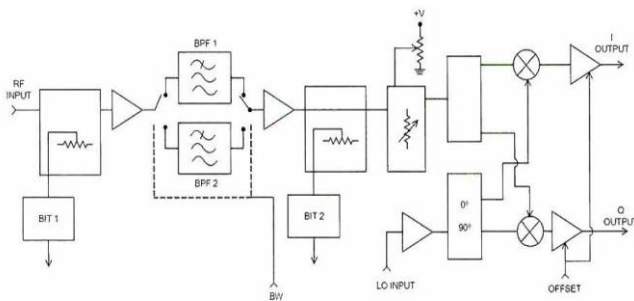

IQ - DETECTOR MODULE
BLOCK DIAGRAM