

Standards
NF C 96-315
MIL-DTL-3933

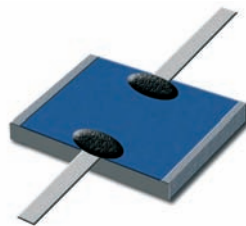

Substrate	AlN
Resistive film	Thick film
Tab	Brass/Ag
Protection film	Epoxy
Tab Attachment	Brazed with epoxy encapsulation

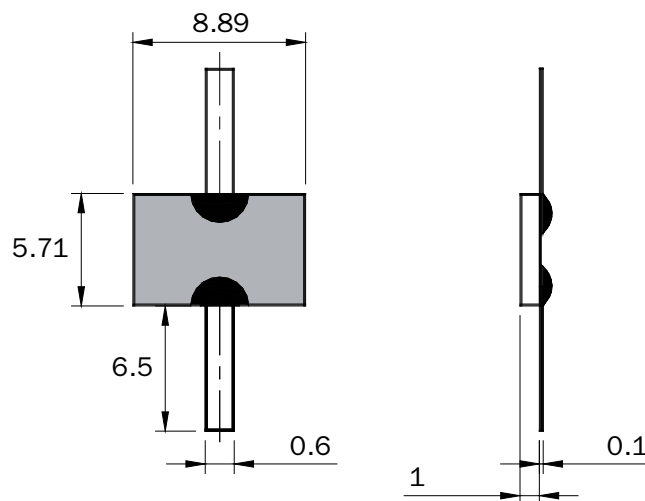
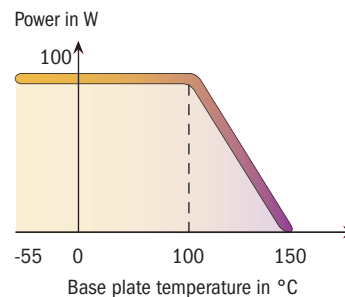

Dimensions in mm

P/N	Attenuation* (dB)	Frequency (GHz)	Power (W)	Impedance ($\Omega \pm 5\%$)	Max VSWR	Accuracy $\pm \Delta\alpha$ (dB)
16-6721	20	3	100	50	1.20	0.5
16-6722	30	3	100	50	1.20**	1.5

mm	inch
0.1	0.004
0.6	0.024
1	0.040
5.71	0.225
6.5	0.256
8.89	0.350

* Others values on request
** VSWR < 1.20 at 2.5 GHz