

PX1004-1

**82.2 MHz
SAW Filter**

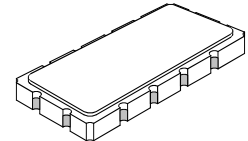

SM13365-12

- **Low Insertion Loss**
- **Excellent Selectivity**
- **Hermetic 13.3 X 6.5 mm Surface-mount Case**
- **Single-ended Input and Output**
- **Complies with Directive 2002/95/EC (RoHS)**

Absolute Maximum Ratings



Rating	Value	Units
Maximum Incident Power in Passband	+10	dBm
Maximum DC Voltage Between any 2 Terminals	30	VDC
Storage Temperature Range	-40 to +85	°C
Suitable for Lead-free Soldering - Maximum Soldering Profile	260°C for 30 s	

Characteristic	Sym	Notes	Min	Typ	Max	Units
Nominal Center Frequency	f_c	1	82.20			MHz
Passband Insertion Loss at f_c 3 dB Passband Amplitude Ripple over $f_c \pm 15$ kHz Group Delay Variation over $f_c \pm 17$ kHz	IL	1, 2		3.0	5.5	dB
	BW_3		± 25	± 42		kHz
	GDV				1.0	dB _{P-P}
Third-Order Intermod. for -20 dBm tones at $f_c \pm 100$ & 200 kHz					6.0	μ S _{P-P}
Rejection $f_c \pm 100$ kHz $f_c - 1500$ kHz to $f_c - 1600$ kHz Ultimate		1, 2, 3	11	16		dB
			65			
				65		
Operating Temperature Range	T_A	1	-20		+70	°C
Impedance Matching to 50 Ω unbalanced	External L-C					
Case Style	SM13365-12 13.3 X 6.5 mm Nominal Footprint					
Lid Symbolization (YY=year, WW=week) See note 4	RFM PX1004-1 YYWW					

Electrical Connections

Connection	Terminals
Port 1 Hot	2
Port 1 Gnd Return	3
Port 2 Hot	8
Port 2 Gnd Return	9
Case Ground	All Others

NOTES:

- Unless noted otherwise, all specifications apply over the operating temperature range with filter soldered to the specified demonstration board with impedance matching to 50 Ω and measured with 50 Ω network analyzer.
- Unless noted otherwise, all frequency specifications are referenced to the nominal center frequency, f_c .
- Rejection is measured as attenuation below the minimum IL point in the passband. Rejection in final user application is dependent on PCB layout and external impedance matching design. See Application Note No. 42 for details.
- "LRIP" or "L" after the part number indicates "low rate initial production" and "ENG" or "E" indicates "engineering prototypes."
- The design, manufacturing process, and specifications of this filter are subject to change.
- Either Port 1 or Port 2 may be used for either input or output in the design. However, impedances and impedance matching may vary between Port 1 and Port 2, so that the filter must always be installed in one direction per the circuit design.
- US and international patents may apply.
- RFM, stylized RFM logo, and RF Monolithics, Inc. are registered trademarks of RF Monolithics, Inc.
- Electrostatic Sensitive Device. Observe precautions for handling.



Amplitude and Group Delay Plots

12 May 2010 08:54:27

CH1 LOG 10 dB/ REF -4.461 dB
S21 1: 0.0000 dB 0.000 000 MHz

CH3 DEL 1 us/ REF 12.14 us
S21 3: 1.0290 us .034 000 MHz

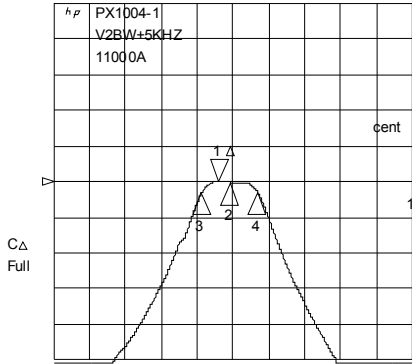

CH1 Markers
Max Δ REF=1
BW : .077195 MHz
cent : 82.195848 MHz
Q: 1064 .8
loss : -4.4410 dB

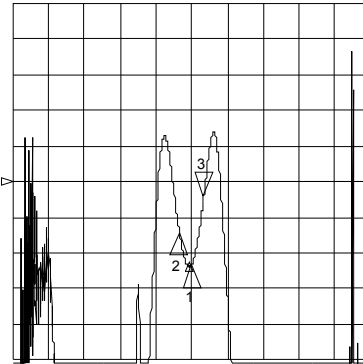

CH3 Markers
Δ REF=2
mean : 10.307 us
s. dev : 533.58 ns
p-p : 1.9680 us

CENTR 82.200 MHz SPAN .500 MHz

CENTR 82.200 MHz SPAN .500 MHz

CH2 S21 LOG 10 dB/ REF -4.655 dB 1: 0.0000 dB 0.000 000 MHz

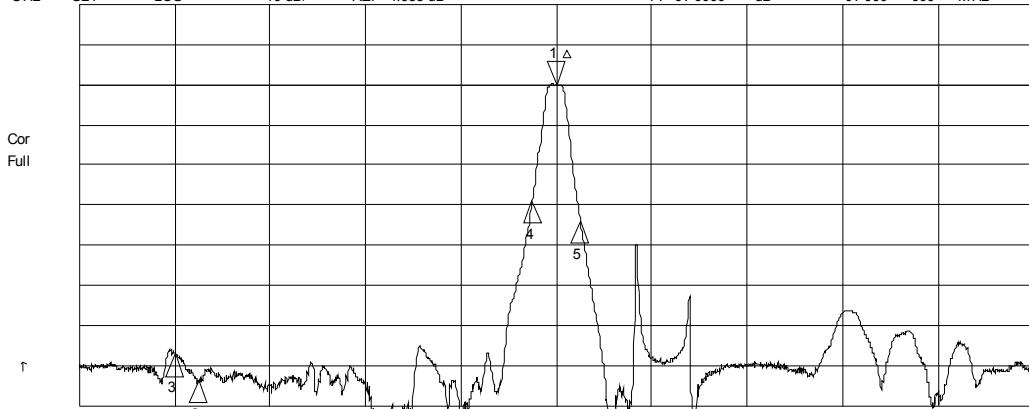

CH2 Markers
Δ REF=1
2: -73.756 dB
-1: 50000 MHz
3: -67.039 dB
-1: 60000 MHz
4: -28.942 dB
-100: 0.000 kHz
5: -33.889 dB
100: 0.000 kHz

CENTER 82.200 000 MHz SPAN 4.000 000 MHz

Input/Output Impedance and Passband Amplitude Plots

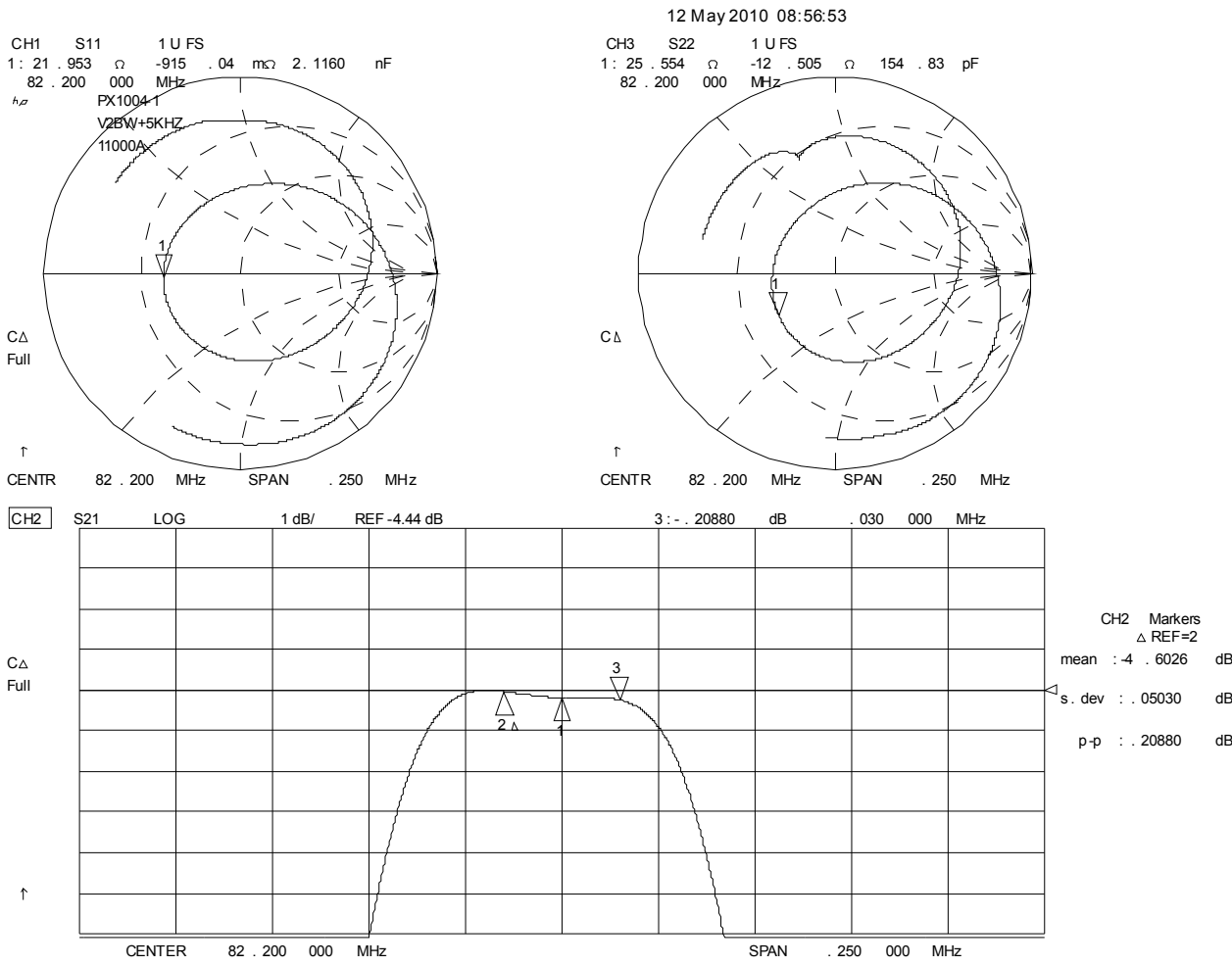

Filter Test Circuit

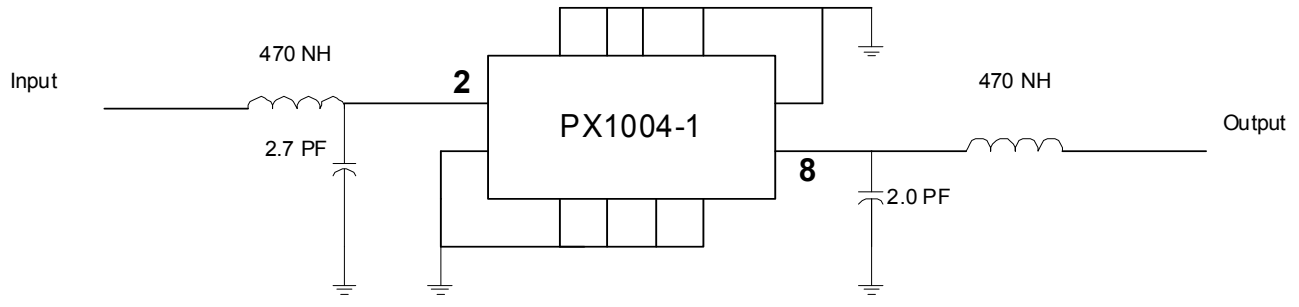

SM13365-12 Ceramic 12-Terminal Surface-Mount Case

13.3 x 6.5 mm Nominal Footprint

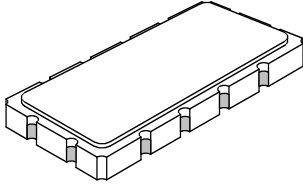

Dimension	Case Dimensions					
	mm			Inches		
	Min	Nom	Max	Min	Nom	Max
A	13.08	13.31	13.60	0.515	0.524	0.535
B	6.27	6.50	6.80	0.247	0.256	0.268
C		1.91	2.00		0.075	0.079
D		1.50			0.059	
E		0.79			0.031	
H		1.0			0.039	
P		2.54			0.100	

Materials	
Solder Pad Plating	0.3 to 1.0 μm Gold over 1.27 to 8.89 μm Nickel
Lid Plating	2.0 to 3.0 μm Nickel
Body	Al_2O_3 Ceramic
	Pb Free

Electrical Connections		
Connection		Terminals
Port 1	Input	2
	Return	3
Port 2	Output	8
	Return	9
	Ground	All others
Single-ended Operation		Return is ground

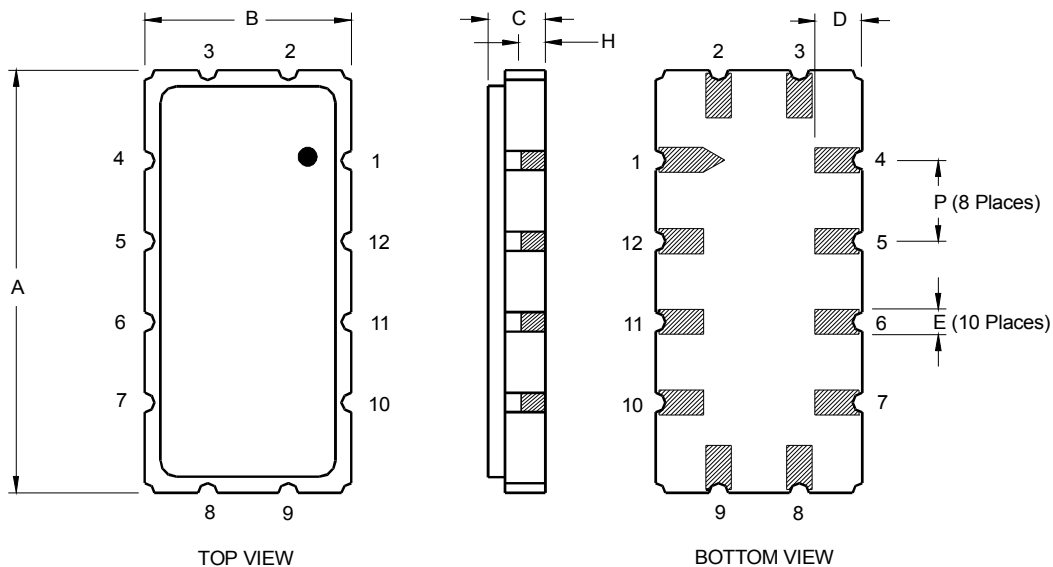

Tape and Reel Specifications

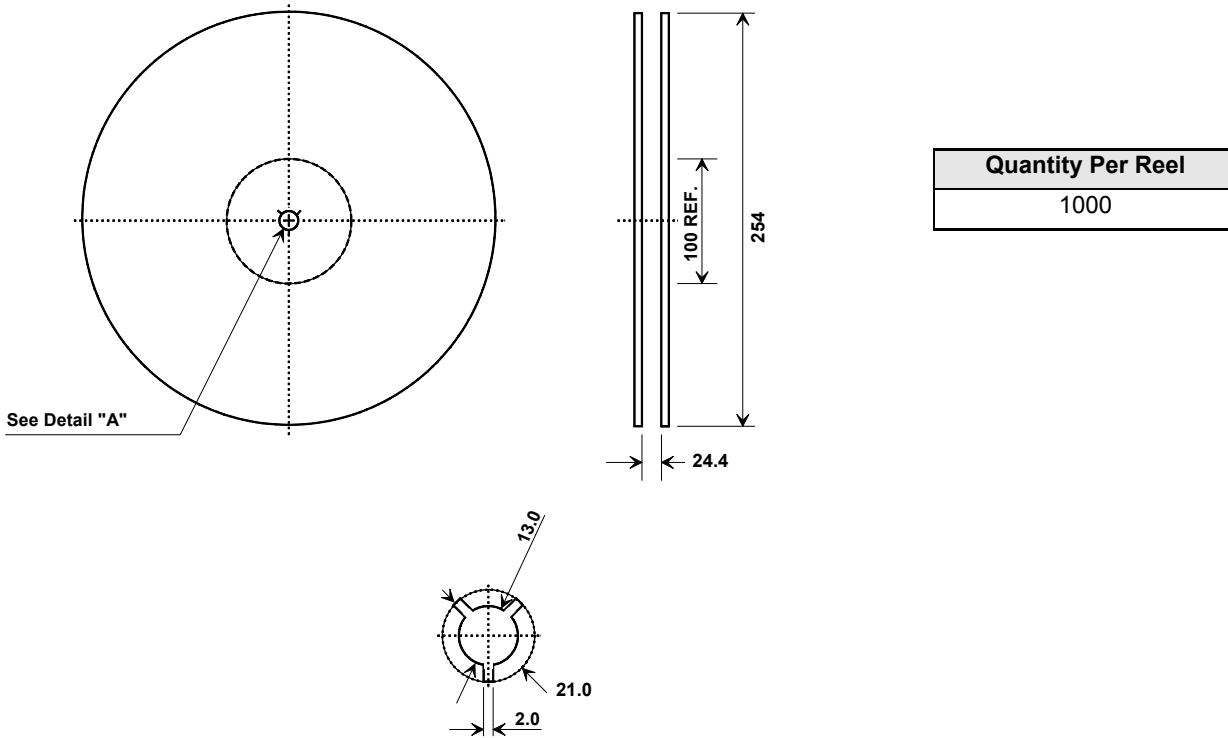

Quantity Per Reel
1000

COMPONENT ORIENTATION and DIMENSIONS

Carrier Tape Dimensions	
Ao	7.0 mm
Bo	13.8 mm
Ko	2.0 mm
Pitch	12.0 mm
W	24.0 mm

