

- **Designed for SDARS IF Receiver**
- **Low Insertion Loss**
- **5.0 X 7.0 mm Surface-Mount Case**
- **Differential Input and Output**
- **Complies with Directive 2002/95/EC (RoHS)**

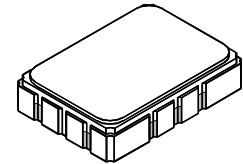

SF1143B

315.00 MHz
SAW Filter



SMP-03

Absolute Maximum Ratings

Rating	Value	Units
Maximum Incident Power in Passband	+10	dBm
Max. DC voltage between any 2 terminals	30	VDC
Storage Temperature Range	-40 to +85	°C
Max Soldering Profile	265°C for 10 s	

Characteristic	Sym	Notes	Min	Typ	Max	Units
Nominal Center Frequency	f_c	1	315.000			MHz
Passband	Insertion Loss at f_c	1		15.1	17.0	dB
	1dB Passband		BW_1	± 6.35	± 7.05	
	Fast Amplitude Ripple over $f_c \pm 6.35$ MHz	1, 2			1.0	dB _{P-P}
	Group Delay Variation over $f_c \pm 6.35$ MHz	GDV		23	200	ns _{P-P}
Rejection	100 to $f_c - 10.3$ and $f_c + 10.3$ to $f_c + 100$ MHz	1, 2, 3	40	TBD		dB
Operating Temperature Range	T_A	1	-40		+85	°C
Differential Input and Output Impedance	250 ohms					
Case Style	SMP-03 7 x 5 mm Nominal Footprint					
Lid Symbolization (YY=year, WW=week, S=shift) See note 4	RFM SF1143B YYWWS					

Electrical Connections

Connection	Terminals
Port 1 Hot	10
Port 1 Ground Return	1
Port 2 Hot	5
Port 2 Ground Return	6
Case Ground	All Others

NOTES:

1. Unless noted otherwise, all specifications apply over the operating temperature range with filter soldered to the specified demonstration board with impedance matching to 50 Ω and measured with 50 Ω network analyzer.
2. Unless noted otherwise, all frequency specifications are referenced to the nominal center frequency, f_c .
3. Rejection is measured as attenuation below the minimum IL point in the passband. Rejection in final user application is dependent on PCB layout and external impedance matching design. See Application Note No. 42 for details.
4. "LRIP" or "L" after the part number indicates "low rate initial production" and "ENG" or "E" indicates "engineering prototypes."
5. The design, manufacturing process, and specifications of this filter are subject to change.
6. Tape and Reel Standard ANSI / EIA 481.
7. Either Port 1 or Port 2 may be used for either input or output in the design. However, impedances and impedance matching may vary between Port 1 and Port 2, so that the filter must always be installed in one direction per the circuit design.
8. US and international patents may apply.
9. Murata, stylized Murata logo, and Murata N.A., Inc. are registered trademarks of Murata Manufacturing Co., Ltd.
10. Electrostatic Sensitive Device. Observe precautions for handling.



NOTES:

- 1 ~~SOLDER "TAPE" 2 PLACES ONTO COMPONENT SIDE OF PCB AS SHOWN.~~
- 2 USE A WRIST STRAP WHEN SOLDERING TRANS 1, AND TRANS 2 TO PCB. (CUT LEADS .07 IN.)
- 3 MOUNT AND SOLDER ALL COMPONENTS ON PCB.
- 4 CUT CENTER CONDUCTORS FROM J1 AND J2 TO .10 IN.
- 5 MOUNT J1 AND J2 AS SHOWN (SOLDER BACKSIDE ALSO).
- 6 LABEL DEMO BOARD ACCORDINGLY.
- 7 MOUNT "FILTER" ON TOPSIDE OF PCB AS SHOWN.
8. ~~CUT ETCH UNDER COMPONENT.~~
9. CUT SHIELD IN TWO PIECES..."SHIELD A" AND "SHIELD B". SOLDER TO PCB AS SHOWN.

REV	ECN	DESCRIPTION	DATE
A	9194	INITIAL RELEASE	22nov00
B	10654	REVISED	30apr02
C	11075	REVISED	20nov02

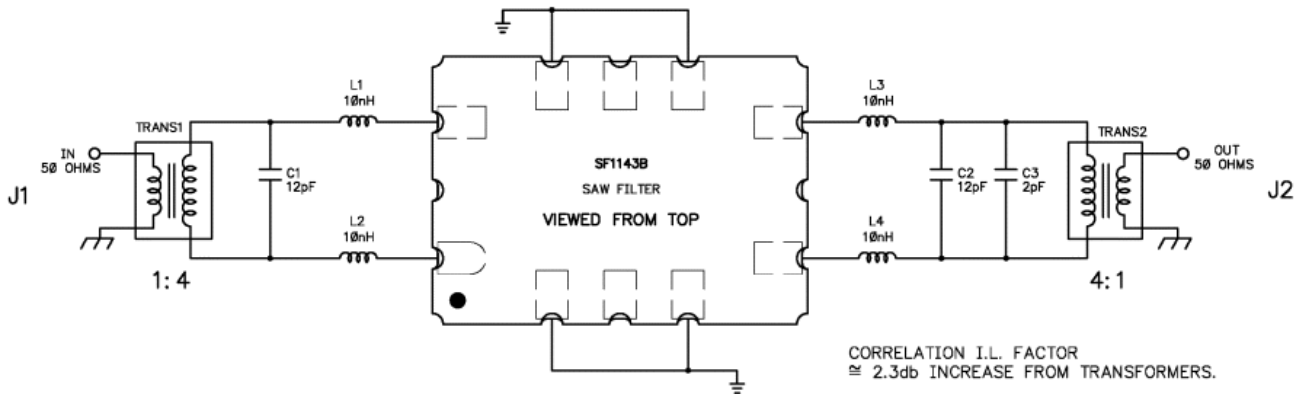

TITLE				
ASSY DIAGRAM, SF1143B-DEMO, S, TD				
SIZE	FSCM NO.	DWG. NO.	REV	SHEET
B	2U874	SF1143B-100	C	1/2

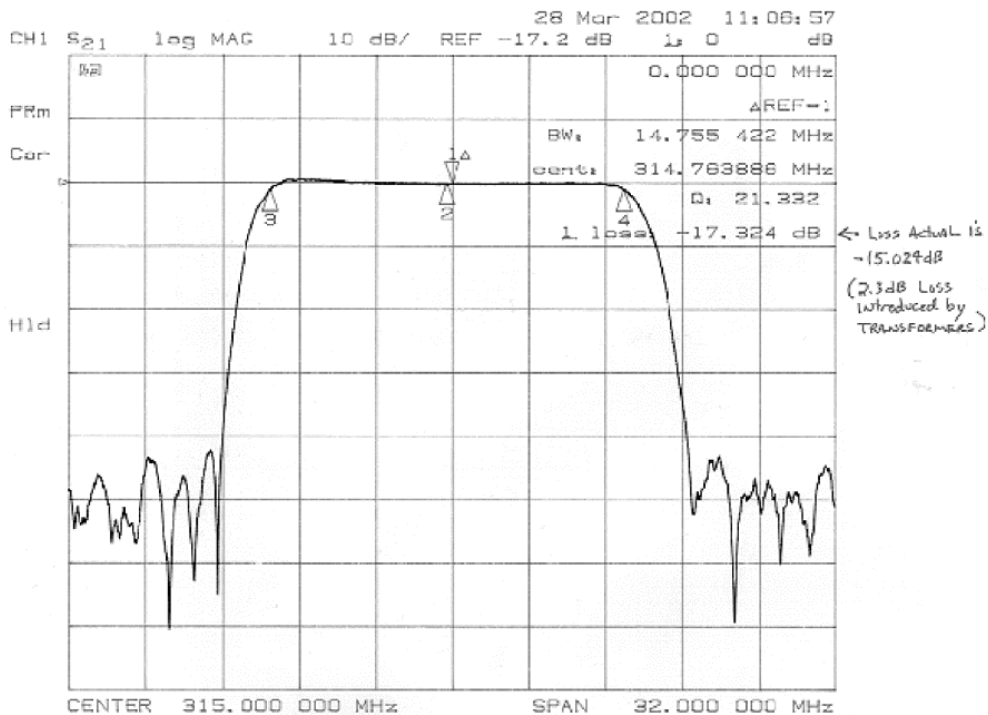
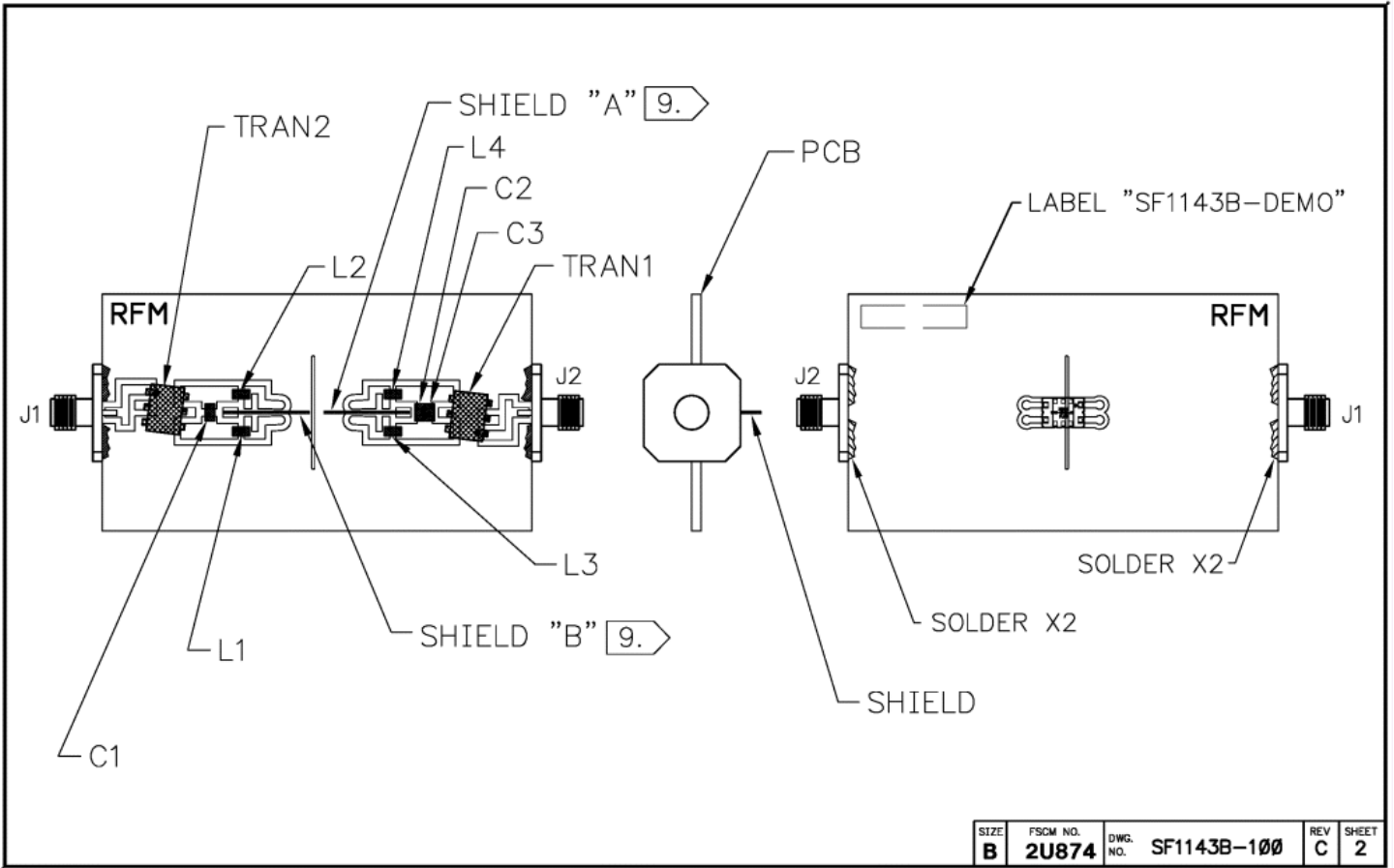

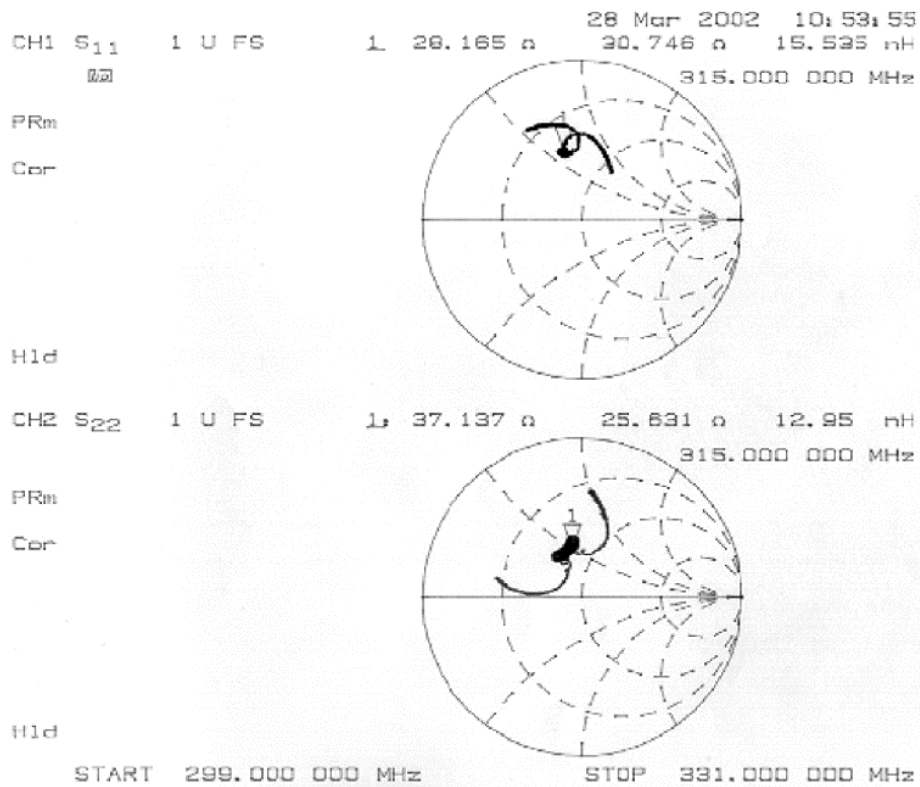
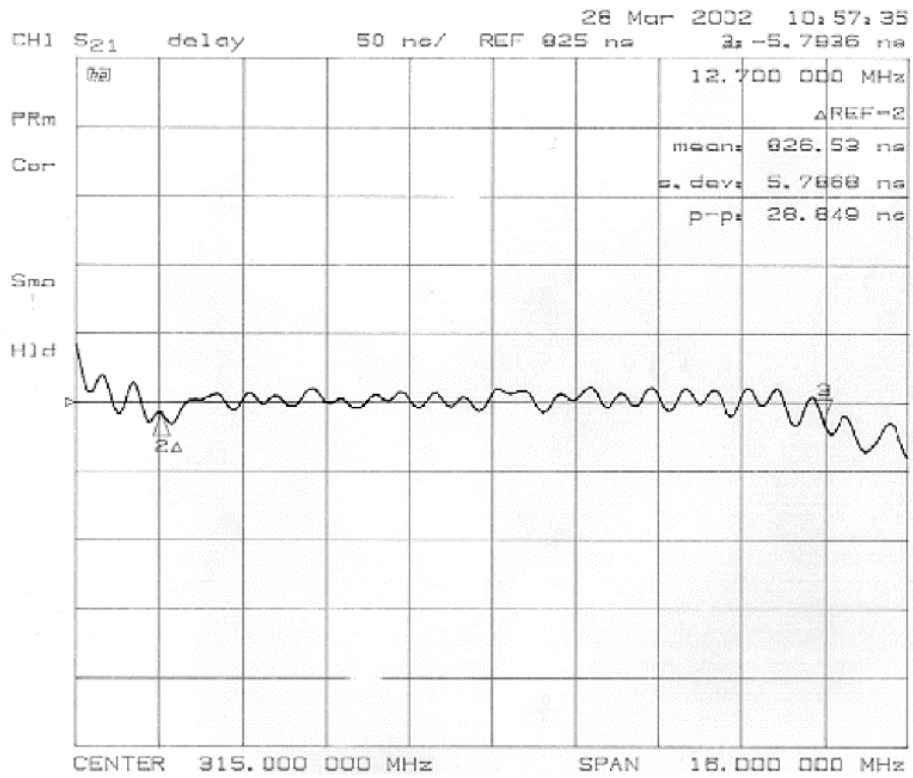

Tape and Reel Specifications

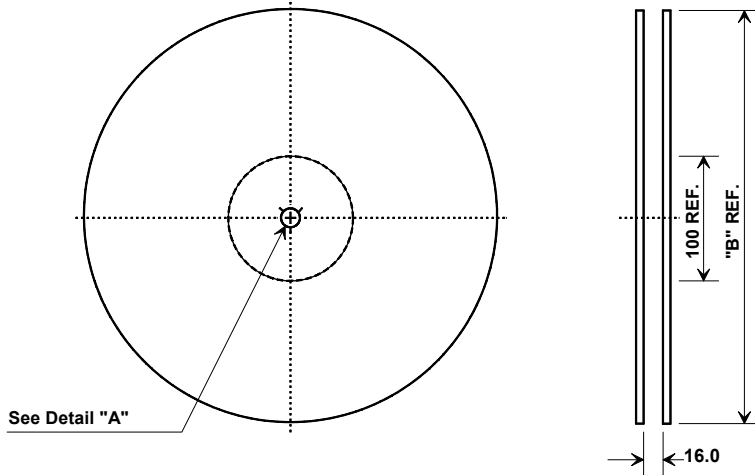

"B "		Quantity Per Reel
Nominal Size		
Inches	millimeters	
7	178	500
13	330	2000

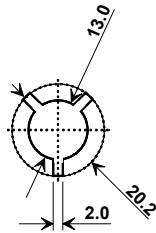

COMPONENT ORIENTATION and DIMENSIONS

Carrier Tape Dimensions		Tolerance
Ao	5.5 mm	± 0.1mm
Bo	7.5 mm	± 0.1mm
Ko	2.0 mm	± 0.1mm
Pitch	8.0 mm	± 0.1mm
W	16.0 mm	± 0.2mm

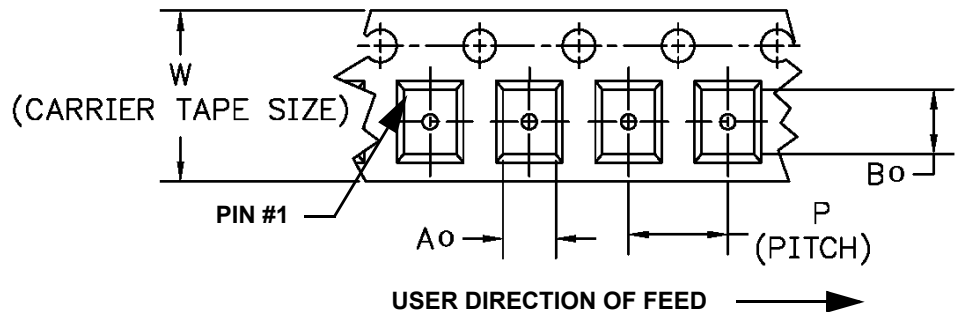

SMP-03 Case

10-Terminal Ceramic Surface-Mount Case

7 x 5 mm Nominal Footprint

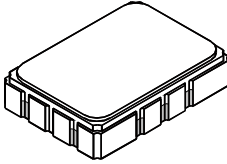

Recommended PCB Footprint

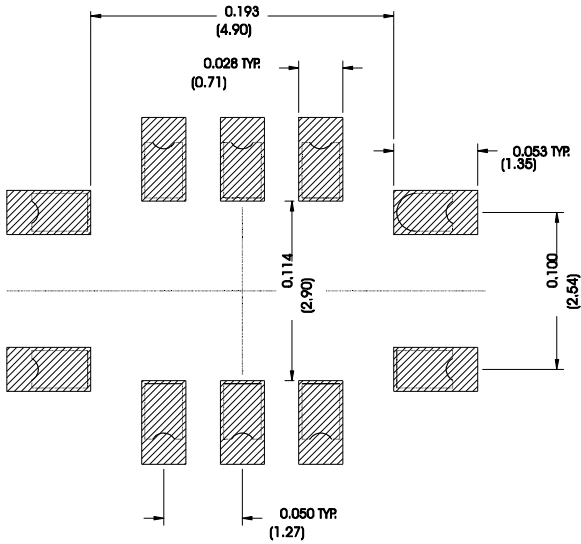

Case Dimensions						
Dimension	mm			Inches		
	Min	Nom	Max	Min	Nom	Max
A	6.80	7.00	7.20	0.268	0.276	0.283
B	4.80	5.00	5.20	0.189	0.197	0.205
C		1.65	2.00		0.065	0.079
D	.47	0.60	.73	0.019	0.024	0.029
E	2.41	2.54	2.67	0.095	0.100	0.105
H	0.87	1.0	1.13	0.034	0.039	0.044
J	4.87	5.00	5.13	0.192	0.197	0.202
K	2.87	3.00	3.13	0.113	0.118	0.123
P	1.14	1.27	1.40	0.045	0.050	0.055

Materials	
Solder Pad Termination	Au plating 30 - 60 ulnches (76.2-152 uM) over 80-200 ulnches (203-508 uM) Ni.
Lid	Fe-Ni-Co Alloy Electroless Nickel Plate (8-11% Phosphorus) 100-200 ulnches Thick
Body	Al ₂ O ₃ Ceramic
Pb Free	

Electrical Connections		
Connection		Terminals
Port 1	Input or Return	10
	Return or Input	1
Port 2	Output or Return	5
	Return or Output	6
Ground		All others
Single Ended Operation		Return is ground
Differential Operation		Return is hot

