

# Programmable Attenuators



## Models 4226 & 4228 Pin Switched Programmable Attenuators

0.8 to 2.5/3.0 GHz

Low Insertion Loss, Fast Switching

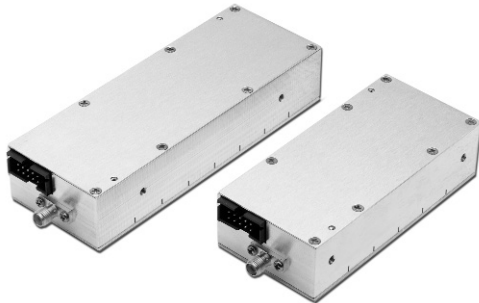

### Features

Ideal for use in Wireless/Cellular, RF Simulation/Emulation, & Communication Test Applications.

- /// Available in 6 and 8 Cell Configurations -
  - 103 dB/1 dB steps
  - 63 dB/1 dB steps
  - 63.75/0.25 dB steps
- /// High accuracy & fast switching speed
- /// Built-in TTL Driver Circuitry
- /// Special Configurations Available Upon Request.
  - Custom Cell/Step Size & Frequency Bands

### Specifications

**NOMINAL IMPEDANCE:** 50 Ω  
**FREQUENCY RANGE:** 4226-63: 0.8 to 3.0 GHz  
 4228-63.75: 0.8 to 2.5 GHz  
 4228-103: 0.8 to 3.0 GHz

MAXIMUM SWR:	
Frequency Range (GHz)	SWR
0.8 - 3.0 (2.5)	1.50

CELL CONFIGURATIONS:			
Model Number	NO. Cells	Attenuation Range/Steps (dB)	Cell Increments (dB)
4228-103	8	103/1	1, 2, 4, 8, 16, 24, 48
4228-63.75	8	63.75/0.25	0.25, 0.5, 1, 2, 4, 8, 16, 32
4226-63	6	63/1	1, 2, 4, 8, 16, 32

INCREMENTAL ATTENUATION ACCURACY:										
CELL	0.25	0.50	1	2	4	8	16	24	32	48
dB	±0.1	±0.15	±0.2	±0.2	±0.2	±0.2	±0.3	±0.4	±0.6	±0.8

MAXIMUM INSERTION LOSS (dB):			
Frequency (GHz)	4226-63	4228-63.75	4228-103
0.8 - 3.0 (2.5)	3.75	4.50	5.50

**MONOTONICITY:** 4226-63 & 4228-103: 0.8 to 3.0 GHz  
 4228-63.75: 0.8 to 2.5 GHz (minimum 1 dB change)

**3rd ORDER INTERMODULATION (IM3):** -55 dBm typical, measured with two +10 dBm tones @ 869 MHz (f1) and 891 MHz (f2), the IM3 frequency being 847 MHz (2f1-f2).

$$IP3 \text{ (input)} = +41 \text{ dBm}$$

The input IP3 is derived from the following relationship:

$$IP3 = \frac{3(P_{in-\alpha}) - IM3 + \alpha}{2}$$

where α = the insertion loss (dB) at the IM3 frequency;  
 Pin=single tone input power (dBm).

**POWER RATING:** +24 dBm operating  
 +30 dBm (1 dB compression point)

**SWITCHING TIME:** 2 μsec. maximum

**OPERATING VOLTAGE:** +5 V ± 5% @ 160 mA for 6 cell/  
 200 mA for 8 cell typical

**TEMPERATURE RANGE (Operating):** 0°C to +70°C

**TEMPERATURE COEFFICIENT:** < 0.002 dB/dB/°C

**CONNECTORS:** SMA female connectors - mate nondestructively with MIL-C-39012 connectors.

**CONTROL CONNECTOR:** AMP-Latch 10 pin ribbon cable connector mates with AMP P/N 746285-1 (supplied with each unit)

**WEIGHT:** 4226-X 160 g (5.7 oz)  
 4228-X 210 g (7.4 oz)

**CONTROL CONFIGURATION:** Units are supplied with a built-in TTL interface. Each unit is supplied with a mating 10 pin connector (Amp 746285-1). Refer to Physical Dimensions for mating connector pin/wiring details. Two wires are specified for supply voltage and ground. The remaining wires will accept TTL control signals to activate or de-activate a particular attenuation cell. A TTL high will energize a cell to the high attenuation state, whereas a TTL low will maintain a cell in its zero attenuation state.

### DRIVER SPECIFICATIONS:

		minimum	maximum
V <sub>IH</sub>	Input High Level	2.0 V	5.3 V
V <sub>IL</sub>	Input Low Level	-0.3 V	0.8 V
I <sub>PU</sub>	Input Pull-up Current	500 μA Typical	

Note: Inputs have 10K pull-up resistors.

## PHYSICAL DIMENSIONS:

Models 4226 & 4228:

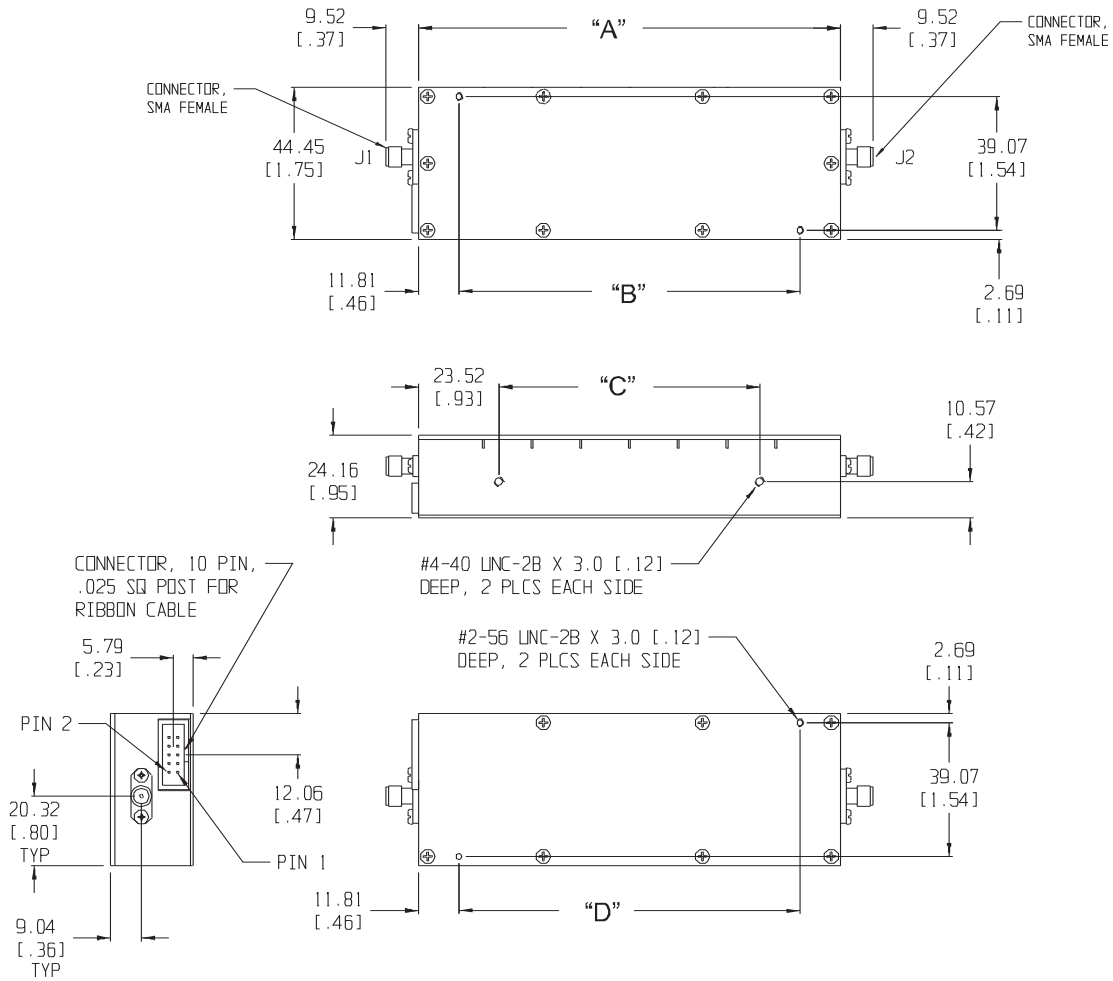

Model No.	A	B	C	D
4226-X	94.79 (3.73)	71.15 (2.80)	76.20 (3.00)	71.15 (2.80)
4228-X	123.24 (4.85)	99.59 (4.85)	76.20 (3.00)	99.59 (4.85)

**NOTE:**

- All dimensions are given in mm (inches) and are maximum, unless otherwise specified.
- Unit available with RoHS compliant materials, specify when ordering.

**Control Connector J3 Pin Locations:**

TTL Conn PIN No. (J3)	4226-63 dB (Cell)	4228-63.75 dB (Cell)	4228-103 dB (Cell)
1	1	0.25	1
2	2	0.50	2
3	4	1	4
4	8	2	8
5	16	4	16
6	32	8	24
7	NC	16	48
8	NC	32	NC*
9	+5V	+5V	+5V
10	COM	COM	COM

NC = Not Connected

\* For Factory use only.