

2

1

REVISION HISTORY			
REV	AUTH	DATE	DESCRIPTION
A	BF	5/30/2008	INITIAL RELEASE
B	BF	4/20/2009	CHANGE DWG #/ ADD 4.87 DIM/ ADD FLANGE NOTE

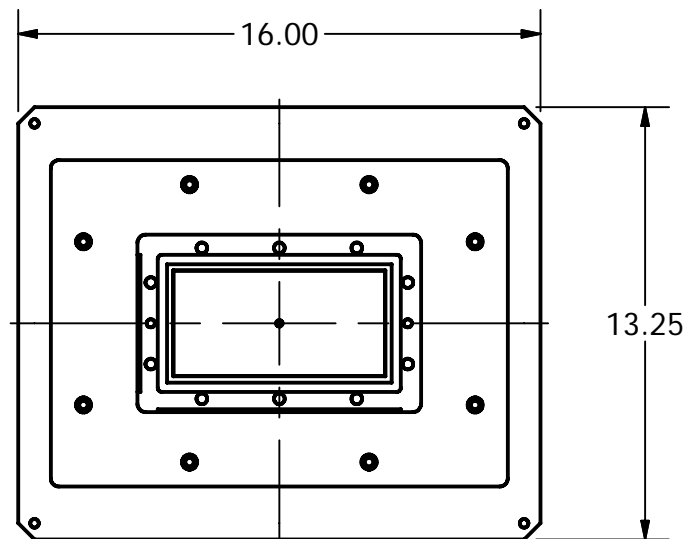
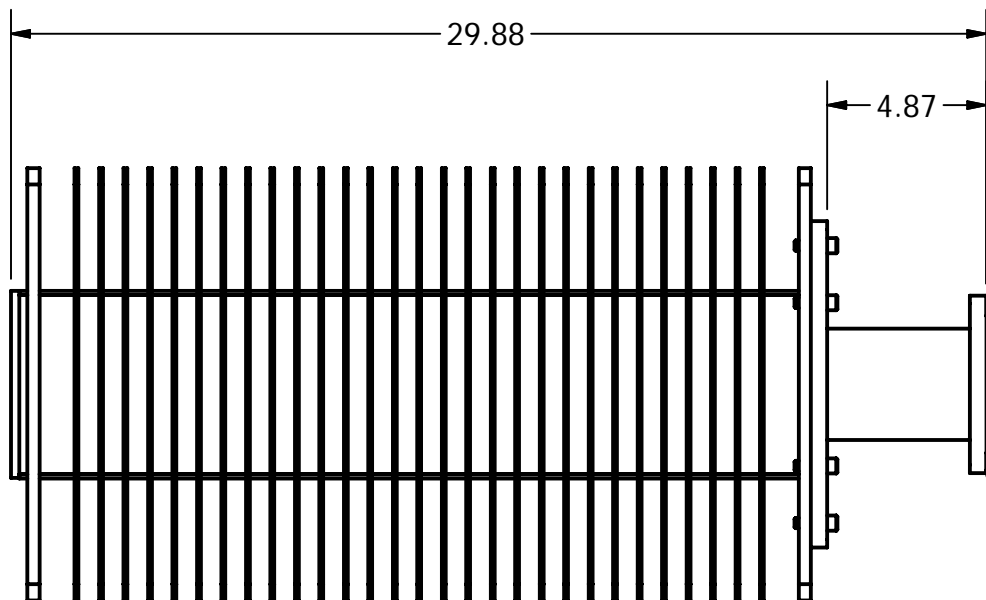

PERFORMANCE SPECIFICATIONS:

MODEL# 650-760-X
WG SIZE: WR650
FREQ RANGE: 1.12-1.70 Ghz
AVG POWER (WATTS): 8000
WEIGHT: APPROX: 150 LBS

FLANGE PER ORDER
 CPRG SHOWN

THIRD ANGLE PROJECTION:		APPROVALS	DATE	ADVANCED TECHNICAL MATERIALS, INC. TEL: (631) 289-0363 FAX: (631) 289-0358 www.atmmicrowave.com		<small>THE INFORMATION IN THIS DRAWING IS PROPRIETARY AND SHALL NOT BE USED OR DISCLOSED WITHOUT THE PRIOR WRITTEN CONSENT OF ATM, INC. DO NOT SCALE DWG.</small>																					
UNLESS OTHERWISE NOTED, DIMENSIONS ARE IN INCHES, TOLERANCES ARE: FRACTIONS: ±1/64 ANGLES: ±1/2°				DRAWN	BF	5-30-08																					
				CHKD.																							
				APRVD.																							
				MATERIAL	AL ALY TYPE 6061-T6																						
				TREATMENT	CHEM FILM																						
				FINISH	HIGH TEMP BLACK																						
<table border="1"> <thead> <tr> <th>BASIC DIMENSION</th> <th>DECIMALS 2 PLACE</th> <th>DECIMALS 3 PLACE</th> </tr> </thead> <tbody> <tr> <td>UNDER 6"</td> <td>±.02</td> <td>±.005</td> </tr> <tr> <td>6" - 12"</td> <td>±.03</td> <td>±.010</td> </tr> <tr> <td>OVER 12"</td> <td>±.06</td> <td>±.015</td> </tr> </tbody> </table>		BASIC DIMENSION	DECIMALS 2 PLACE	DECIMALS 3 PLACE	UNDER 6"	±.02	±.005	6" - 12"	±.03	±.010	OVER 12"	±.06	±.015	<table border="1"> <thead> <tr> <th>SIZE</th> <th>CAGE CODE</th> <th>ATM DWG #</th> <th>REVISION</th> </tr> </thead> <tbody> <tr> <td>A</td> <td>0R8N4</td> <td>9483</td> <td>B</td> </tr> </tbody> </table>	SIZE	CAGE CODE	ATM DWG #	REVISION	A	0R8N4	9483	B	<table border="1"> <thead> <tr> <th>MODEL #</th> <th>SHEET</th> </tr> </thead> <tbody> <tr> <td>650-760-X</td> <td>1 OF 1</td> </tr> </tbody> </table>	MODEL #	SHEET	650-760-X	1 OF 1
BASIC DIMENSION	DECIMALS 2 PLACE	DECIMALS 3 PLACE																									
UNDER 6"	±.02	±.005																									
6" - 12"	±.03	±.010																									
OVER 12"	±.06	±.015																									
SIZE	CAGE CODE	ATM DWG #	REVISION																								
A	0R8N4	9483	B																								
MODEL #	SHEET																										
650-760-X	1 OF 1																										

2

1