

TAT8858

CATV Infrastructure Push-Pull Amplifier



Applications

- CATV Line Amplifiers
- CATV System Amplifiers
- Distribution Nodes
- Green Applications



SOIC-16 Wide Package

Product Features

- 75 Ω , 50 – 1000 MHz Bandwidth
- GaAs pHEMT & MESFET Technology
- User configurable gain: 27 – 34 dB
- Integrated linearization
- Choice of output device to optimize cost/performance
- Flexible bias voltage and current for optimum efficiency
- SOIC-16 Wide Package

Functional Block Diagram

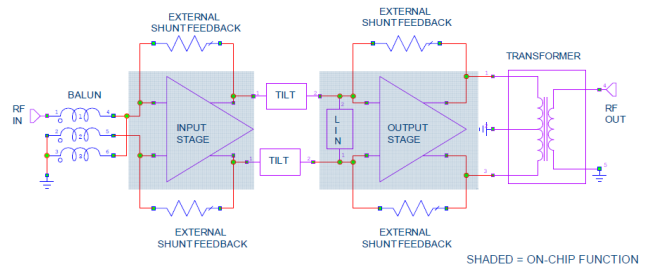

General Description

The TAT8858 is a cost effective 75 Ω RFIC Amplifier designed for use in high gain 24 V CATV applications up to 1000 MHz. It works with readily available SMT baluns and transformers to provide a highly flexible low cost replacement for traditional hybrids.

Gain of the TAT8858 may be easily adjusted by varying external components, allowing for a family of push-pull hybrid solutions to be developed from a single RFIC.

The TAT8858 provides integrated linearization to improve the 3rd order distortion performance.

The TAT8858 may be protected against transient surges with the TQP200002 and an output high pass filter network. Consult TriQuint for discussion.

The TAT8858 supports traditional 24 V and 12 V supply voltages. Bias current may be adjusted to suit particular requirements with standard or active biasing approaches. Consult TriQuint for further discussion.

Pin Configuration

Pin #	Symbol	Pin #	Symbol
1	OUT 1A	10	IN 2B
2	LIN ADJ A	11	OUT 2B
3	IN 1A	12	GATE B
4	BIAS 1A	13	GATE A
5	BIAS 1B	14	OUT 2A
6	IN 1B	15	IN 2A
7	LIN ADJ B	16	BIAS 2A
8	OUT 1B	17	GND
9	BIAS 2B		

Ordering Information

Part No.	Description
TAT8858	RFIC
TAT8858-EB	evaluation board

Standard T/R size = 1000 pieces on a 7" reel.

Specifications

Absolute Maximum Ratings

Parameter	Rating
Storage Temperature	-65 to 150 °C
Operating Temperature	-20 to 85 °C

Operation of this device outside the parameter ranges given above may cause permanent damage.

Recommended Operating Conditions

Parameter	Min	Typ	Max	Units
V _{cc}		24		V
I _{cc}		270		mA

Electrical specifications are measured at specified test conditions. Specifications are not guaranteed over all recommended operating conditions.

Electrical Specifications

Test conditions unless otherwise noted: 25°C case temp, +24V V_{supply}

Parameter	Conditions	Min	Typical	Max	Units
Operational Frequency Range		50		1000	MHz
Test Frequency					MHz
Gain @ Low Frequency	Mid range of gain		32		dB
Input Return Loss			18		dB
Output Return Loss			16		dB
CTB	See Note 1		-69		dBc
CSO	See Note 1		-68		dBc
CIN	See Note 1		70		dB
XMOD	See Note 1		-61		dBc
Noise Figure			3.0		dB
V _{bias}			24		V
I _{dd}	See Note 2		270		mA
Thermal Resistance (jnc. to case) θ_{jc}			4.0		°C/W

Notes:

- 79ch. NTSC + QAM (-6dB offset) to 1003.25MHz flat input, 43dBmV/ch V_{out} at ch. 2.
- Active biasing is easily implemented with traditional dual-pnp approaches. Biasing at 12 V is also possible. Refer to pages 5 and 6 for biasing circuit configurations.

TAT8858

CATV Infrastructure Push-Pull Amplifier



Application Circuit 50-1000 MHz

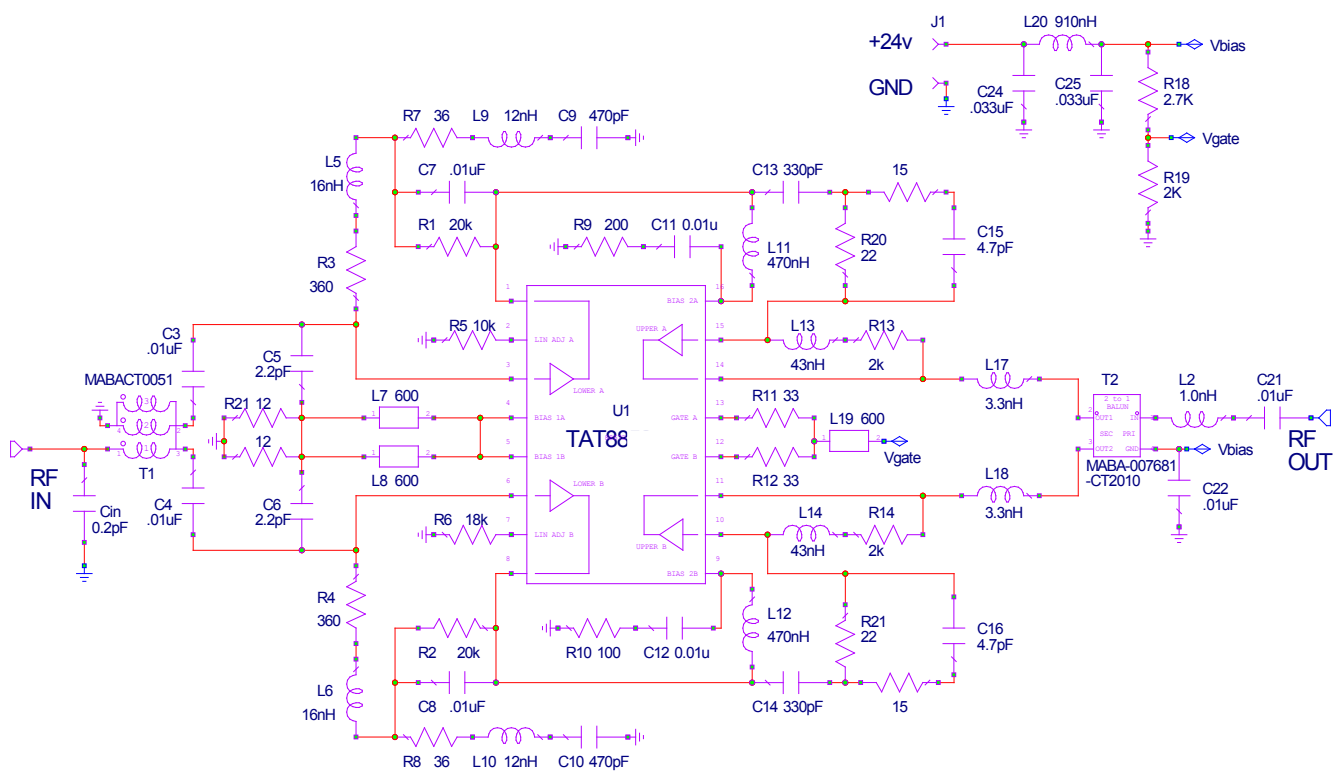

TAT8858

CATV Infrastructure Push-Pull Amplifier



Typical Performance 50-1000 MHz

Notes:

1. 25°C case temp, 24V supply,.
2. 79ch. NTSC + QAM (-6dB offset) to 1003.25MHz flat input, 43dBmV/ch Vout at ch.2

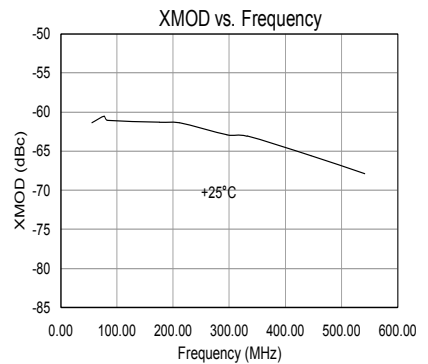
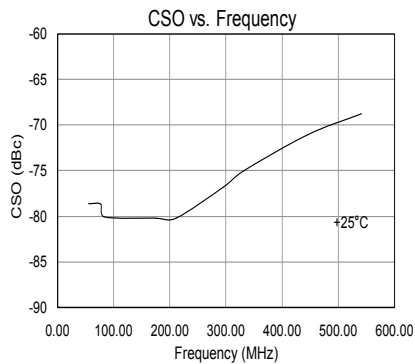
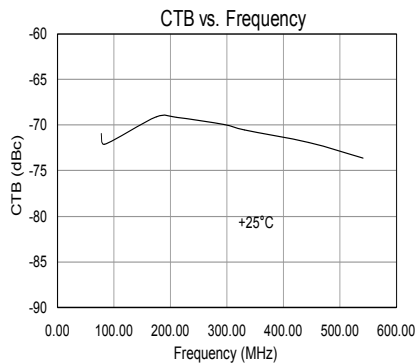
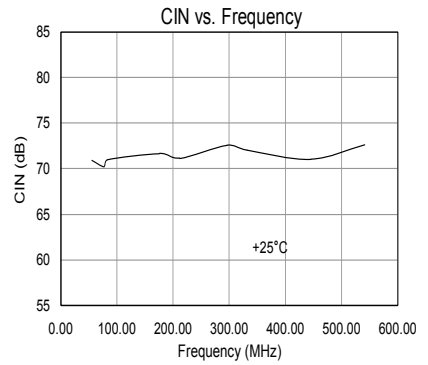
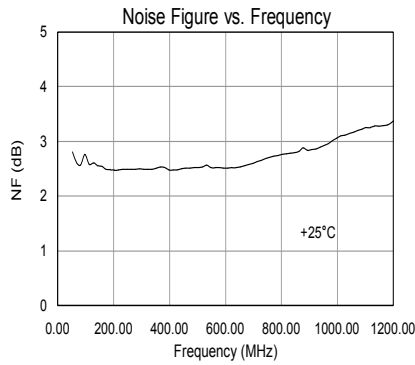
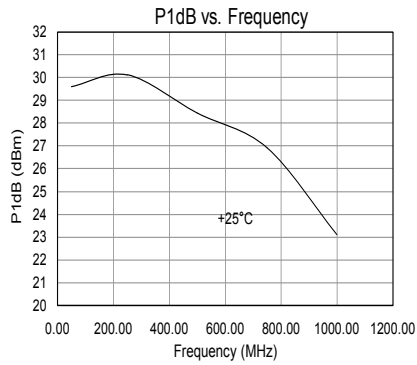
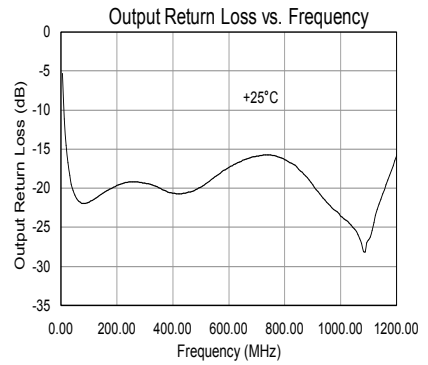
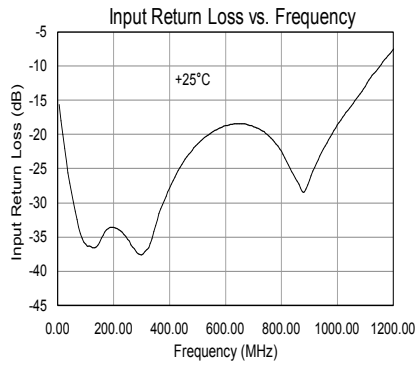
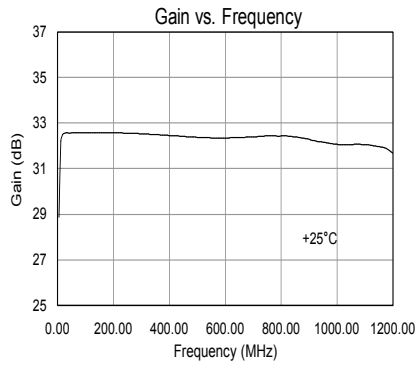

TAT8858

CATV Infrastructure Push-Pull Amplifier



Detailed Device Description

The TAT8858 is similar to other parts offered on the market; it contains two separate amplifiers. A major difference is the TAT8858 allows much flexibility to set gain and bias to cover multiple applications without an additional stage. This makes it ideal for green designs. It uses a cost effective high voltage MESFET technology (designed for CATV) and a pHEMT process (developed for high-volume applications). On-chip linearization is also utilized.

Bias Current Adjustment

Bias current is determined by 2 settings:

1. Size of DC feedback resistors - decreasing R1 & R2 will increase IDD
2. Tail resistors - decreasing R21 will increase IDD, but lead to wider variations

Active biasing schemes are possible but not necessary for most applications.

Best performance is with $I_{DD} = 270\text{mA}$

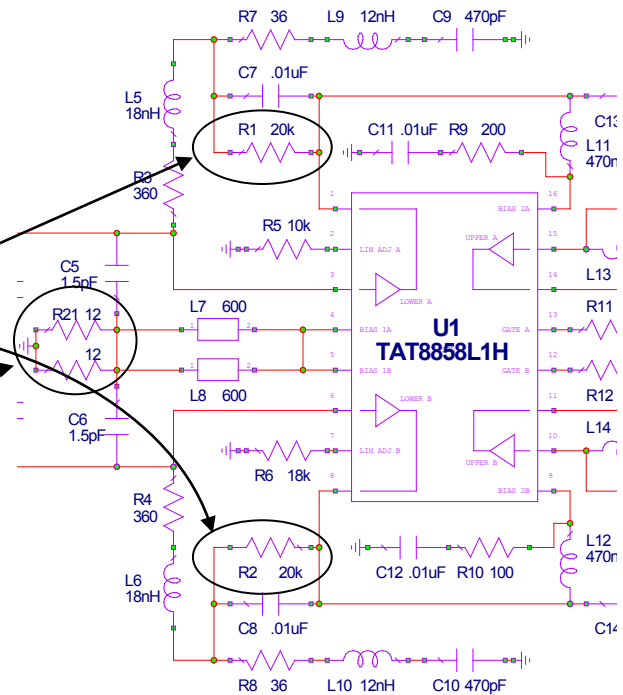

Voltage Biasing: 24V and 12V

The TAT8858 has two amplifiers which can be configured to split a 24 V supply (and share the same current) or both amplifiers can be biased from a 12V supply and draw current independently.

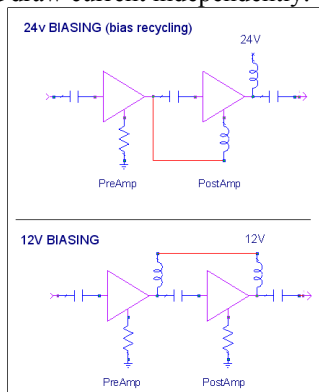

In the 24V case the voltage split ratio is left to the customer and is set by V_{gate} . In 24v applications, no capacitance should be put on V_{gate} ; this prevents a turn-on over-voltage condition from damaging the output FET.

TAT8858

CATV Infrastructure Push-Pull Amplifier

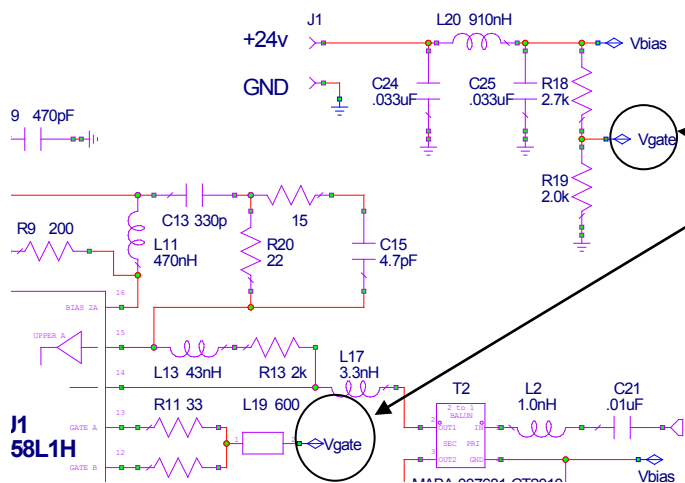

Voltage divider should be done with same or lower resistor values to prevent gate leakage currents in the output FET from affecting V_{gate} .

Additional information can be requested from TriQuint Applications Engineering, sjapplications.engineering@tqs.com.

TAT8858

CATV Infrastructure Push-Pull Amplifier



Mechanical Information

Package Information and Dimensions

This package is lead-free/RoHS-compliant. The plating material on the leads is 100% Matte Tin. It is compatible with both lead-free (maximum 260 °C reflow temperature) and lead (maximum 245 °C reflow temperature) soldering processes.

The TAT8858 will be marked with a “TAT8858” designator with a lot code marked below the part designator. The “Y” represents the last digit of the year the part was manufactured, the “XXXX” is an auto-generated number and “Z” refers to a wafer number in a lot batch.

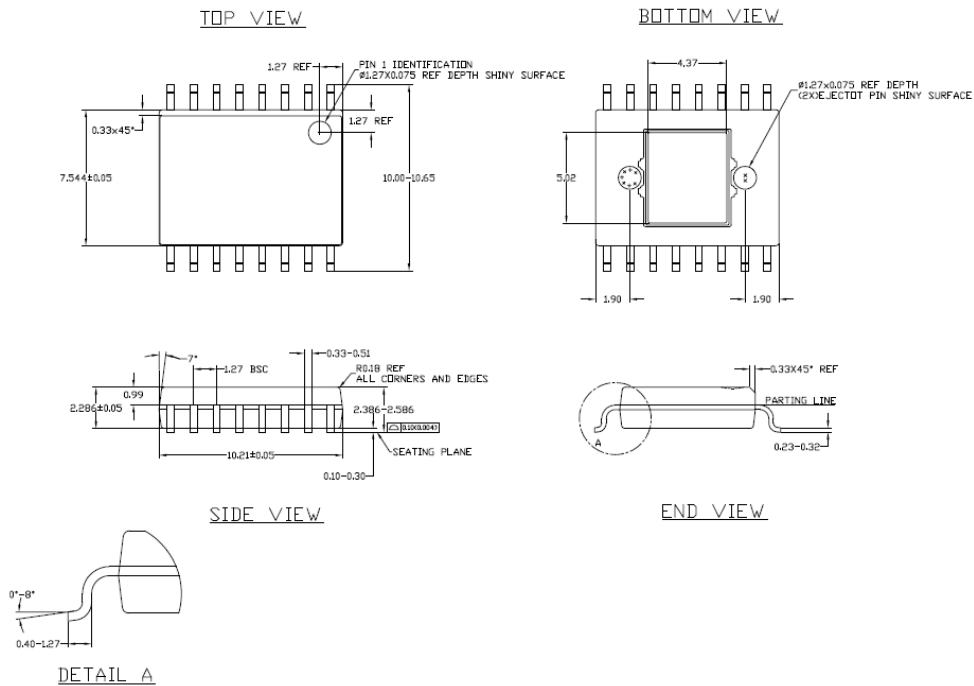

Mounting Configuration

All dimensions are in millimeters (inches). Angles are in degrees.

Notes:

1. A heatsink underneath the area of the PCB for the mounted device is strictly required for proper thermal operation. Damage to the device can occur without the use of one.
2. Ground / thermal vias are critical for the proper performance of this device. Vias should use a .xxmm (#xx / .0xxx”) diameter drill and have a final plated thru diameter of .xx mm (.0xx”).
3. Add as much copper as possible to inner and outer layers near the part to ensure optimal thermal performance.

Product Compliance Information

ESD Information



Caution! ESD-Sensitive Device

ESD Rating: Class III
Value: Passes ≥ 500 V min.
Test: Charged Device Model (CDM)
Standard: JEDEC Standard JESD22-C101

Solderability

Compatible with the latest version of J-STD-020, Lead free solder, 260°

This part is compliant with EU 2002/95/EC RoHS directive (Restrictions on the Use of Certain Hazardous Substances in Electrical and Electronic Equipment).

MSL Rating

Level 3 at +260 °C convection reflow
The part is rated Moisture Sensitivity Level <xy> at 260°C per JEDEC standard IPC/JEDEC J-STD-020.

Contact Information

For the latest specifications, additional product information, worldwide sales and distribution locations, and information about TriQuint:

Web: www.triquint.com
Email: info-sales@tqs.com

Tel: +1.707.526.4498
Fax: +1.707.526.1485

For technical questions and application information:

Email: sjcapplcations.engineering@tqs.com

Important Notice

The information contained herein is believed to be reliable. TriQuint makes no warranties regarding the information contained herein. TriQuint assumes no responsibility or liability whatsoever for any of the information contained herein. TriQuint assumes no responsibility or liability whatsoever for the use of the information contained herein. The information contained herein is provided "AS IS, WHERE IS" and with all faults, and the entire risk associated with such information is entirely with the user. All information contained herein is subject to change without notice. Customers should obtain and verify the latest relevant information before placing orders for TriQuint products. The information contained herein or any use of such information does not grant, explicitly or implicitly, to any party any patent rights, licenses, or any other intellectual property rights, whether with regard to such information itself or anything described by such information.

TriQuint products are not warranted or authorized for use as critical components in medical, life-saving, or life-sustaining applications, or other applications where a failure would reasonably be expected to cause severe personal injury or death.