

RFAM3790

45-1218MHZ GAAS
EDGE QAM INTEGRATED AMPLIFIER



The RFAM3790 is an Integrated Edge QAM Amplifier Module. The part employs GaAs pHEMT die, GaAs MESFET die, a 20dB range variable attenuator and a power enable feature, has high output capability, and is operated from 45MHz to 1218MHz. It provides excellent linearity and superior return loss performance with low noise and optimal reliability.

Package: 9 pin,
11.0 mm x 11.0 mm x 1.375mm

Features

- Excellent Linearity
- Extremely High Output Capability
- Voltage Controlled Attenuator
- Power Enable Feature
- Extremely Low Distortion
- Optimal Reliability
- Low Noise
- Unconditionally Stable Under all Terminations
- 27.5 dB Typical Gain at 1218MHz
- 410mA Typical at 12VDC

Applications

- 45MHz to 1218MHz Downstream Edge QAM RF Modulators
- Headend Equipment

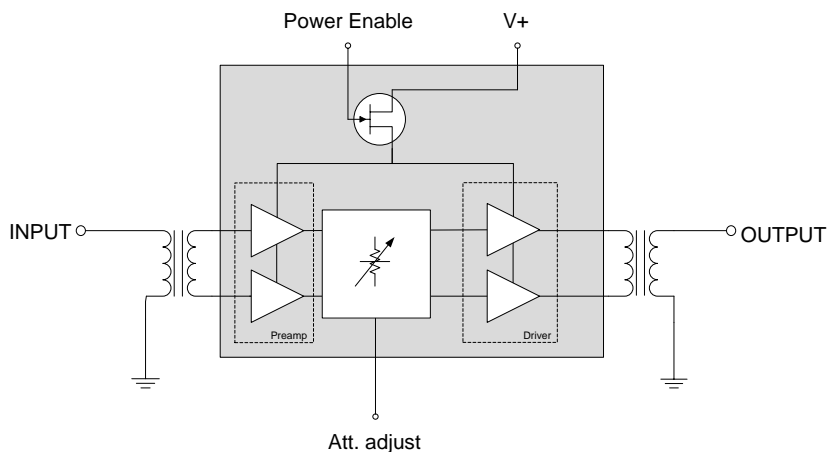

Functional Block Diagram

Ordering Information

RFAM3790SB	Sample bag with 5 pieces
RFAM3790SQ	Sample bag with 25 pieces
RFAM3790SR	7" Reel with 100 pieces
RFAM3790TR7	7" Reel with 250 pieces
RFAM3790TR13	13" Reel with 750 pieces
RFAM3790PCBA-410	Fully Assembled Evaluation Board
RFAM3790PCK-410	Fully Assembled Evaluation Board with Sample Bag

Absolute Maximum Ratings

Parameter	Rating	Unit
DC Supply Over-Voltage (5 minutes)	14	V
Storage Temperature	-40 to +100	°C
Operating Mounting Base Temperature	-30 to +100	°C
Moisture Sensitivity Level IPC/JEDEC J-STD-20	MSL 3 @260	°C



Caution! ESD sensitive device.



RoHS status based on EU Directive 2011/65/EU

Exceeding any one or a combination of the Absolute Maximum Rating conditions may cause permanent damage to the device. Extended application of Absolute Maximum Rating conditions to the device may reduce device reliability. Specified typical performance or functional operation of the device under Absolute Maximum Rating conditions is not implied.

Nominal Operating Parameters

Parameter	Specification			Unit	Condition
	Min	Typ	Max		
General Performance					V+= 12V; TMB=30°C; ZS=ZL=75Ω; Att=0dB
Power Gain		27.0		dB	f=45MHz
	27.5	28.5	29.5	dB	f=1218MHz
Slope ^[1]	0.5	1.5	2.5	dB	f=45MHz to 1218MHz
Flatness of Frequency Response		0.5	1.0	dB	f=45MHz to 1218MHz (Peak to Valley)
Input Return Loss	18			dB	f=45MHz to 1003MHz
	16			dB	f=1003MHz to 1218MHz
Output Return Loss	15			dB	f=45MHz to 1003MHz
	15			dB	f=1003MHz to 1218MHz
Noise Figure		4.0	5.0	dB	f=50MHz to 1218MHz
Total Current Consumption (DC)		410	450	mA	
Attenuator					V+= 12V; TMB=30°C; ZS=ZL=75Ω;
Attenuator Range	0 to 20			dB	Attenuator Voltage 0V to 12V
Power Enable/Disable					
		Amp enabled			Logic high (3.3V) applied to power enable pin ^[2]
		Amp disabled			Logic low (0V) applied to power enable pin ^[3]

Parameter	Specification			Unit	Condition
	Min	Typ	Max		
Distortion					V+= 12V; TMB=30°C; ZS=ZL=75Ω; Att=0dB
Adjacent Channel Power Ratio (ACPR); N=4 contiguous 256QAM channels			-58	dBc	Channel Power = 58dBmV; Adjacent channel up to 750 kHz from channel block edge
			-60	dBc	Channel Power = 58dBmV; Adjacent channel (750 kHz from channel block edge to 6MHz from channel block edge)
			-63	dBc	Channel Power = 58dBmV; Next-adjacent channel (6 MHz from channel block edge to 12 MHz from channel block edge)
			-65	dBc	Channel Power = 58dBmV; Third-adjacent channel (12 MHz from channel block edge to 18 MHz from channel block edge)
2 nd Order Harmonic (HD2); N=1 256QAM channel			-63	dBc	Channel Power = 66dBmV; In each of 2N contiguous 6 MHz channels coinciding with 2nd harmonic components (up to 1000MHz);
3 rd Order Harmonic (HD3); N=1 256QAM channel			-63	dBc	Channel Power = 66dBmV; In each of 3N contiguous 6 MHz channels coinciding with 3rd harmonic components (up to 1000MHz);
CTB		-67		dBc	V _o =46dBmV _{flat} , 79 analog channels plus 75 digital channels (-6dB offset) ^{[4], [6]}
XMOD		-60		dBc	
CSO		-70		dBc	
CIN		64		dB	
CTB		-67		dBc	V _o =45dBmV _{flat} , 79 analog channels plus 111 digital channels (-6dB offset) ^{[5], [6]}
XMOD		-61		dBc	
CSO		-70		dBc	
CIN		65		dB	

- The slope is defined as the difference between the gain at the start frequency and the gain at the stop frequency.
- Logic high is defined as power enable voltage >2V
- Logic low is defined as power enable voltage <0.4V
- 79 analog channels, NTSC frequency raster: 55.25MHz to 547.25MHz, +46dBmV flat output level, plus 75 digital channels, -6dB offset relative to the equivalent analog carrier.
- 79 analog channels, NTSC frequency raster: 55.25MHz to 547.25MHz, +45dBmV flat output level, plus 111 digital channels, -6dB offset relative to the equivalent analog carrier.
- Composite Second Order (CSO) - The CSO parameter (both sum and difference products) is defined by the NCTA. Composite Triple Beat (CTB) - The CTB parameter is defined by the NCTA. Cross Modulation (XMOD) - Cross modulation (XMOD) is measured at baseband (selective voltmeter method), referenced to 100% modulation of the carrier being tested. Carrier to Intermodulation Noise (CIN) - The CIN parameter is defined by ANSI/SCTE 17 (Test procedure for carrier to noise).

Evaluation Board Assembly Drawing

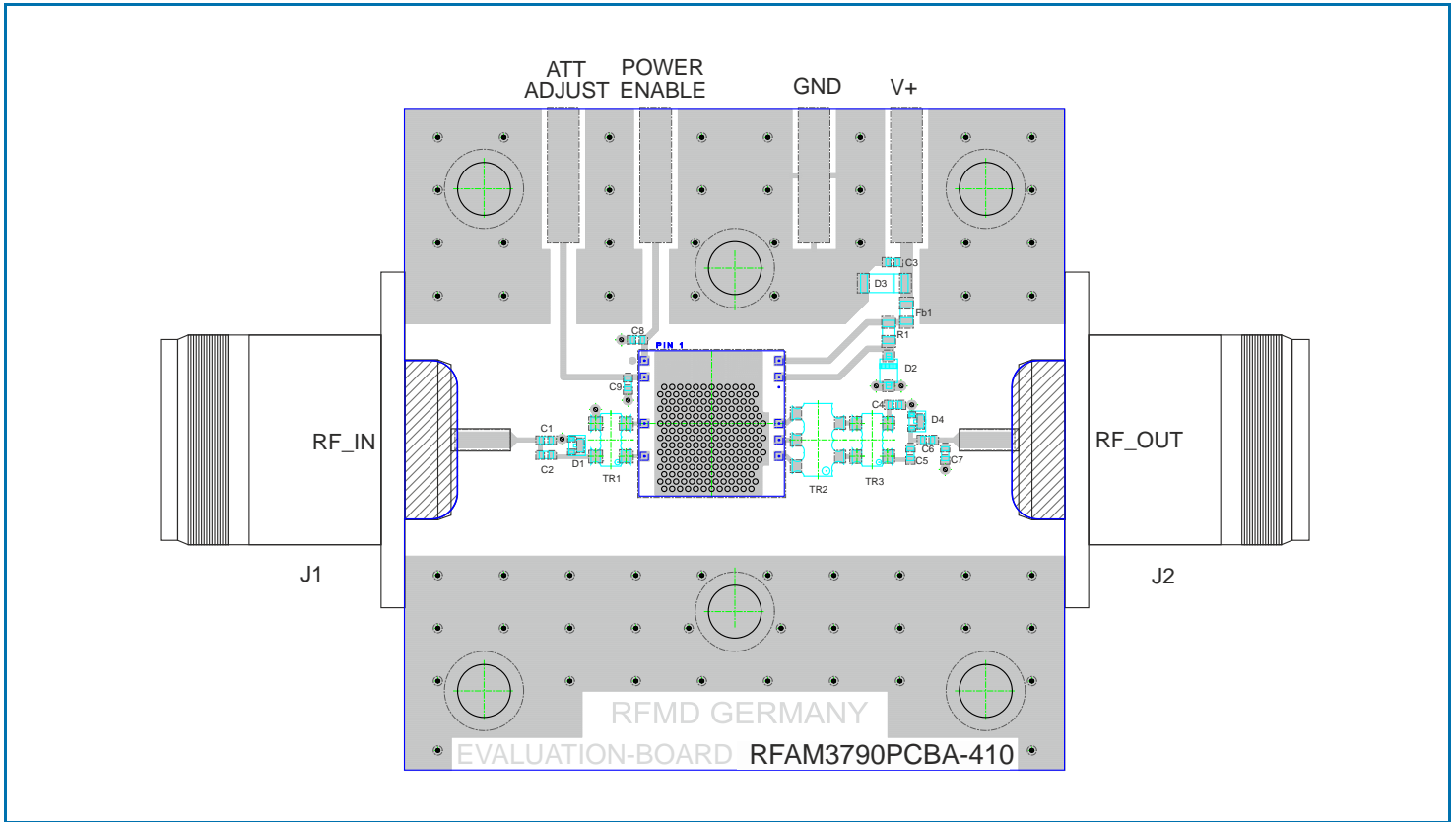

Note:

The ground plane of the RFAM3790 module should be soldered onto a board equipped with as many thermal vias as possible. Underneath this thermal via array a heat sink with thermal grease needs to be placed which is able to dissipate the complete module DC power. In any case the module backside temperature should not exceed 100°C.

Evaluation Board Schematic

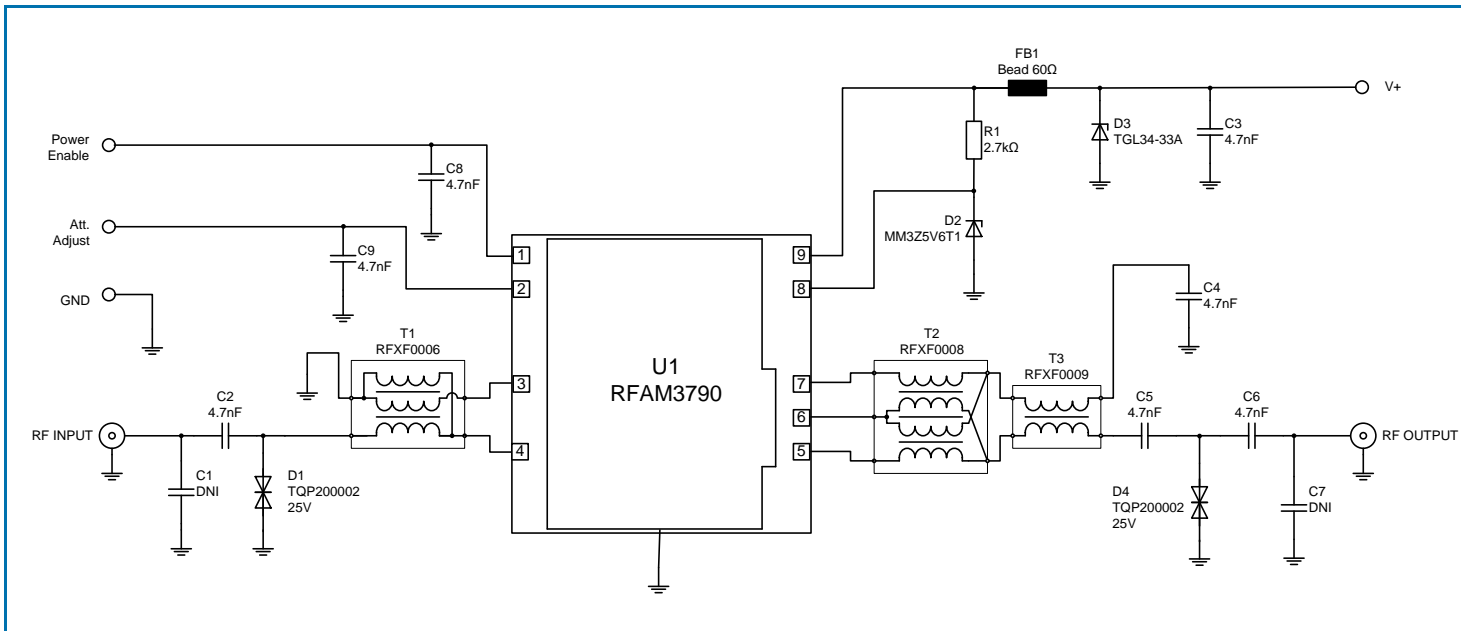

Evaluation Board Bill of Materials (BOM)

Designator	Value	Description	Manufacturer	Part Number
C1	DNI	optional to improve matching in application		
C2, C3, C4, C5, C6, C8, C9	4.7nF	Capacitor, X7R, 50V, 10%		
C7	DNI	optional to improve matching in application		
R1	2.7kΩ	Resistor, TK200, 5%		
FB1	60Ω @ 100MHz	Impedance Bead, DCR 0.1Ohm, 800mA	Taiyo Yuden	BK 1608HS600-T
D1, D4	25V	ESD Protection	Triquint	TQP200002
D2	5.6V	Zener Diode, 200mW	On Semiconductor	MM3Z5V6T1G
D3	33V	Transient Suppressor Diode, 5%	Diotec	TGL34-33A
T1	1:1	Transformer	RFMD	RFXF0006
T2	2.8:1	Transformer	RFMD	RFXF0008
T3	1:1	Transformer	RFMD	RFXF0009
U1		Amplifier	RFMD	RFAM3790

Pin Out

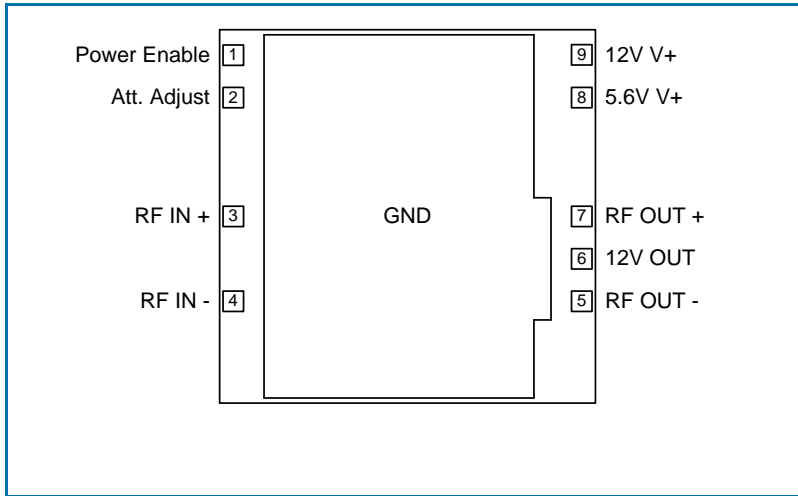

Pin Names and Descriptions

Pin	Name	Description
1	Power Enable	Logic Level (3.3V) Power Enable Control
2	Att. Adjust	Voltage Adjustable Attenuator
3	RF IN (+)	RF AMP Positive Input
4	RF IN (-)	RF AMP Negative Input
5	RF OUT (-)	RF AMP Negative Output
6	12V Out	12V Output
7	RF OUT (+)	RF AMP Positive Output
8	5.6V V+	Supply Voltage 5.6V
9	12V V+	Supply Voltage 12V

Package Outline Drawing (Dimensions in millimeters)

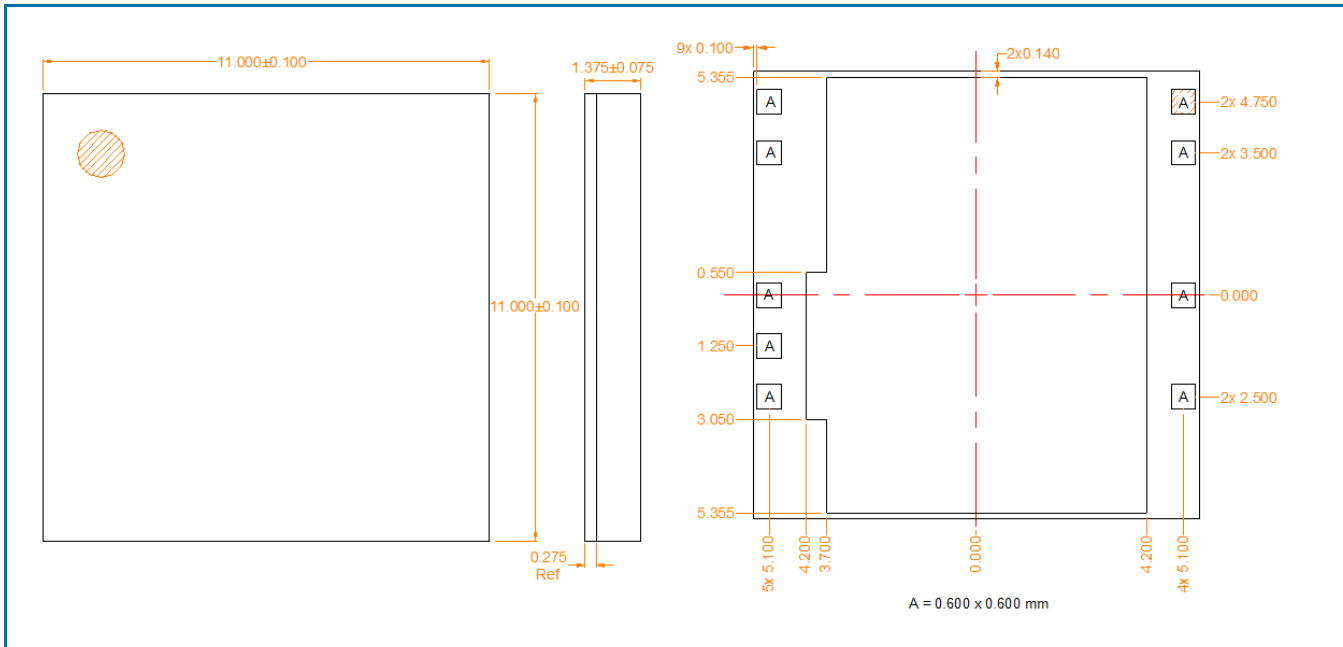

PCB Metal Land Pattern (Dimensions in millimeters)

