



Let Performance Drive

CMD119P3

5-9 GHz Low Noise Amplifier



Features

- ▶ Ultra low noise figure
- ▶ Low current consumption
- ▶ High gain broadband performance
- ▶ Single supply voltage: +3.6 V @ 30 mA
- ▶ Pb-free RoHs compliant 3x3 QFN package

Description

The CMD119P3 is a broadband MMIC low noise amplifier housed in a leadless 3x3 mm plastic surface mount package. The CMD119P3 is ideally suited for microwave radios and C and X-band applications where small size and low power consumption are needed. The broadband device delivers greater than 22 dB of gain with a corresponding output 1 dB compression point of +11 dBm and a noise figure of 1.2 dB. The CMD119P3 is a 50 ohm matched design eliminating the need for external DC blocks and RF port matching. The CMD119P3 amplifier is the perfect alternative to costly hybrid amplifiers.

Applications

- ▶ Point-to-point radios
- ▶ Point-to-multi-point radios
- ▶ Military and Space
- ▶ Test instrumentation

Functional Block Diagram

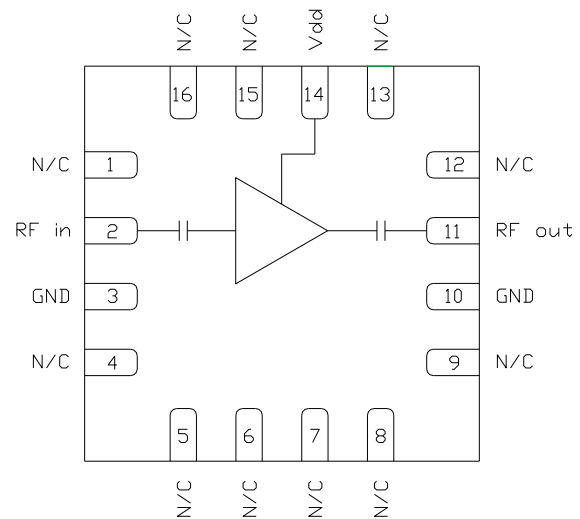

Electrical Performance - $V_{dd} = 3.6 \text{ V}$, $T_A = 25 \text{ }^\circ\text{C}$, $F=8\text{GHz}$

Parameter	Min	Typ	Max	Units
Frequency Range	5 - 9			GHz
Gain		22		dB
Noise Figure		1.2		dB
Input Return Loss		11		dB
Output Return Loss		14		dB
Output P1dB		11		dBm
Supply Current		30		mA

ver 1.2 0612

Specifications

Absolute Maximum Ratings

Parameter	Rating
Drain Voltage, Vdd	5.0 V
RF Input Power	+20 dBm
Channel Temperature, Tch	150 °C
Power Dissipation, P _{diss}	367 mW
Thermal Resistance	177 °C/W
Operating Temperature	-40 to 85 °C
Storage Temperature	-55 to 150 °C

Operation of this device outside the maximum ratings may cause permanent damage.

Recommended Operating Conditions

Parameter	Min	Typ	Max	Units
Vdd	2.0	3.6	4.5	V
I _{dd}		30		mA

Electrical performance is measured at specific test conditions. Electrical specifications are not guaranteed over all recommended operating conditions.

Electrical Specifications - V_{dd} = 3.6 V, T_A = 25 °C

Parameter	Min	Typ	Max	Min	Typ	Max	Units
Frequency Range	5 - 9			7.2 - 8.4			GHz
Gain	20	22.5	25	20	22.5	25	dB
Noise Figure		1.25	1.8		1.2	1.5	dB
Input Return Loss		11			11		dB
Output Return Loss		15			15		dB
Output P1dB		11			11		dBm
Output IP3		21			21		dBm
Supply Current	21	30	39	21	30	39	mA
Gain Temperature Coefficient		0.01			0.01		dB/°C
Noise Figure Temperature Coefficient		0.007			0.007		dB/°C

ver 1.2 0612

Typical Performance

Broadband Performance, $V_{dd} = 3.6\text{ V}$, $I_{dd} = 30\text{ mA}$, $T_A = 25\text{ }^\circ\text{C}$

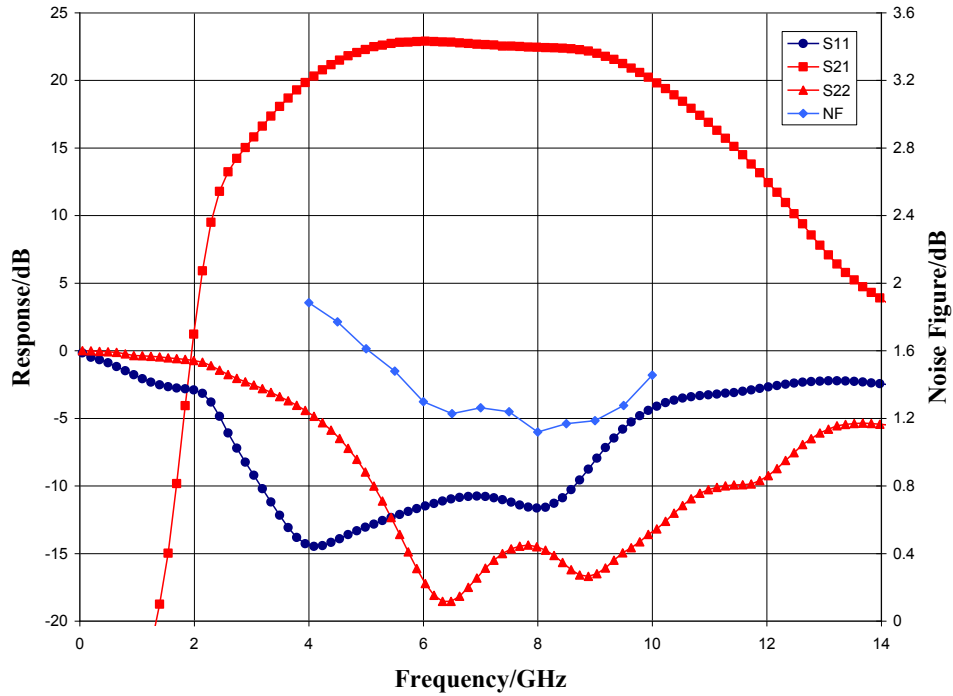

Narrow-band Performance, $V_{dd} = 3.6\text{ V}$, $I_{dd} = 30\text{ mA}$, $T_A = 25\text{ }^\circ\text{C}$

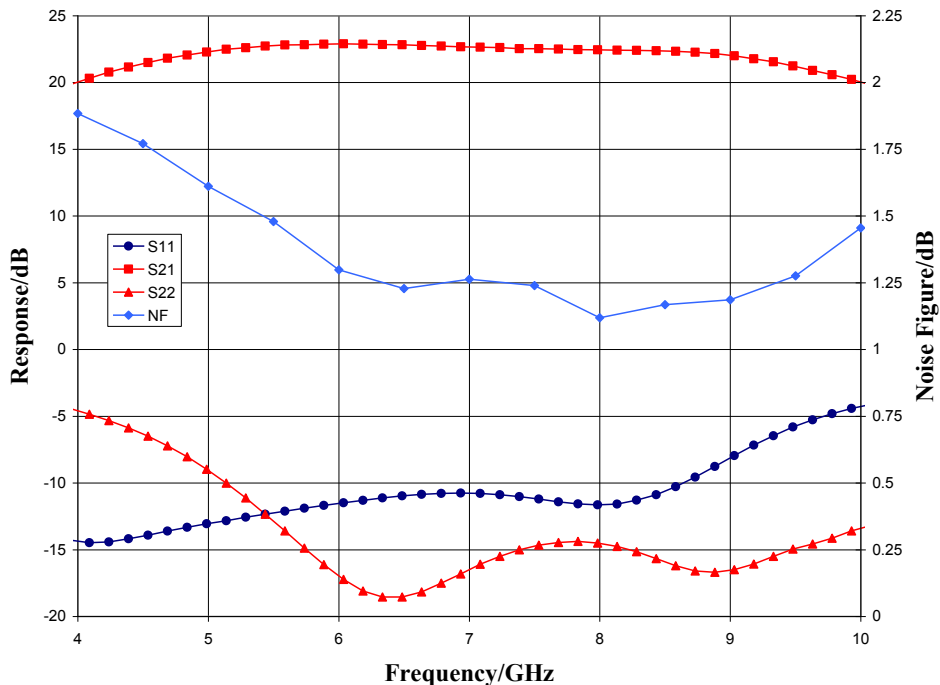

ver 1.2 0612

Typical Performance

Gain vs. Temperature, $V_{dd} = 3.6\text{ V}$

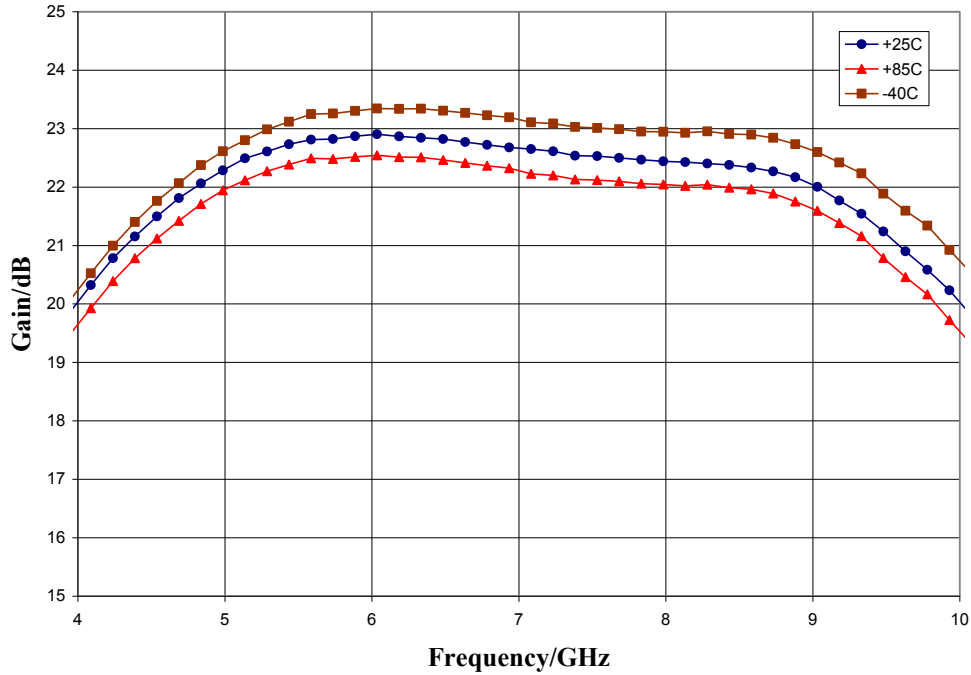

Noise Figure vs. Temperature, $V_{dd} = 3.6\text{ V}$

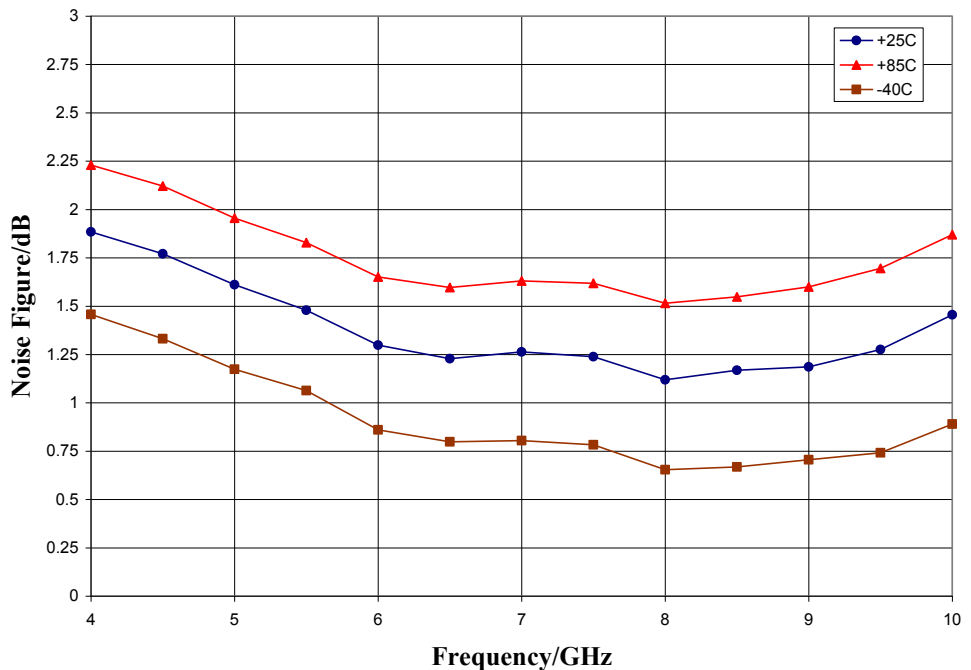

ver 1.2 0612

Typical Performance

Output Power, $V_{dd} = 3.6\text{ V}$, $I_{dd} = 30\text{ mA}$, $T_A = 25\text{ }^\circ\text{C}$

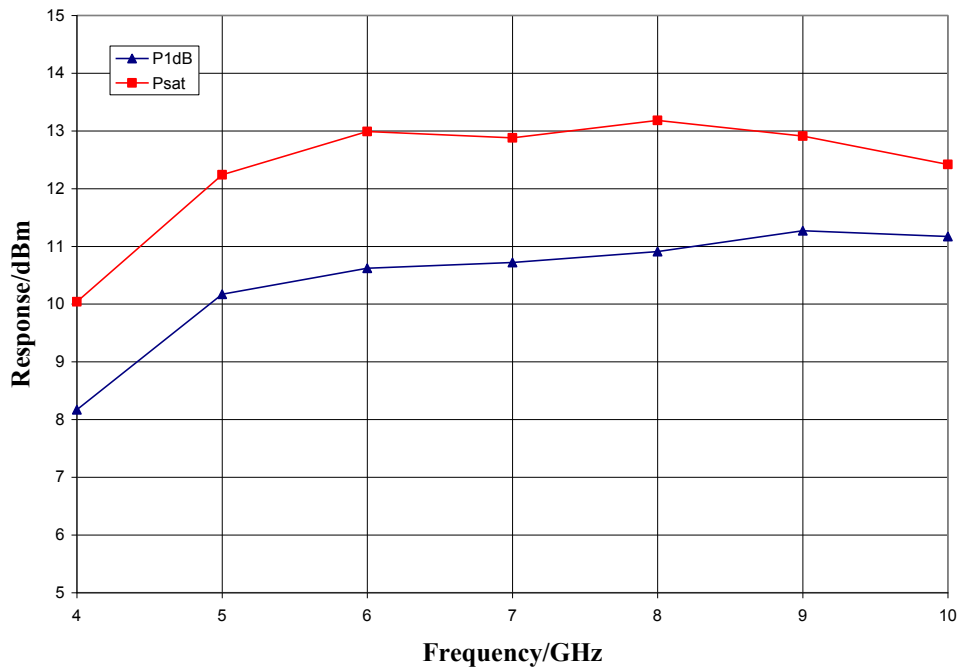

Output IP3, $V_{dd} = 3.6\text{ V}$, $I_{dd} = 30\text{ mA}$, $T_A = 25\text{ }^\circ\text{C}$

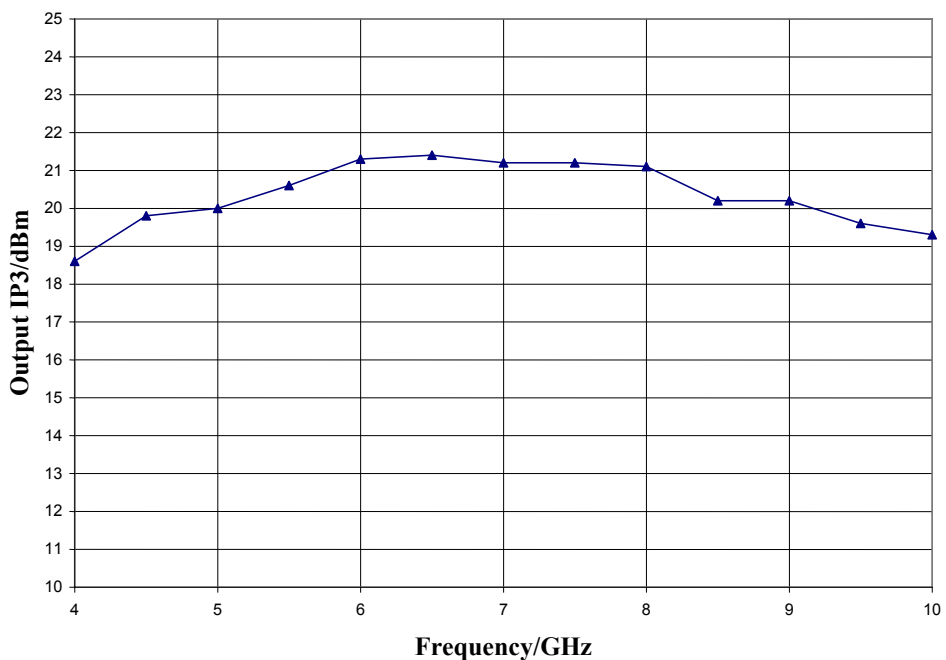

ver 1.2 0612

Mechanical Information

Package Information and Dimensions

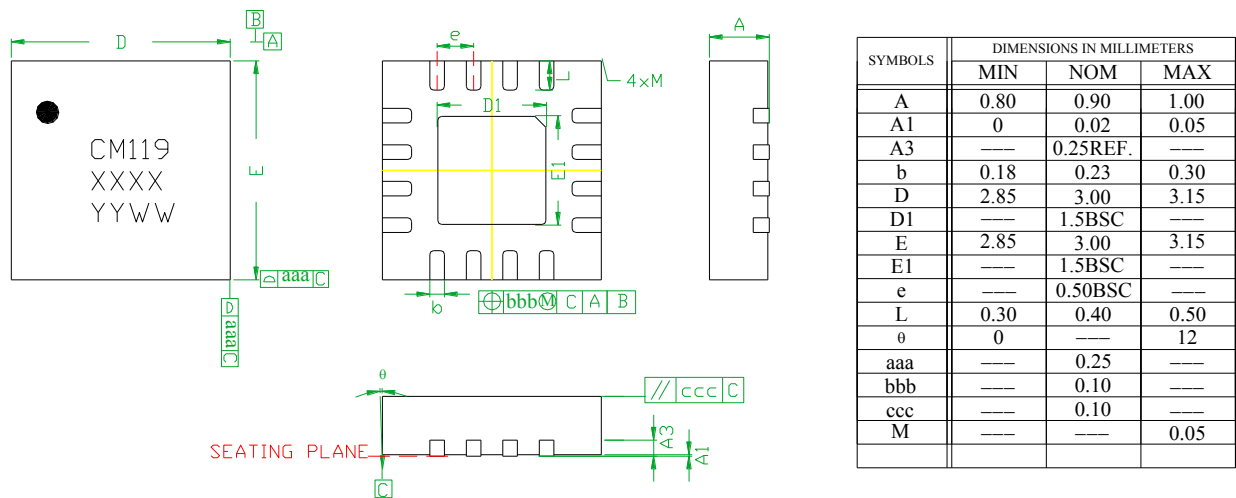

NOTES:

1. DIMENSIONS ARE IN MILLIMETERS
2. RoHS COMPLIANT MOLD COMPOUND
3. LEADFRAME MATERIAL: COPPER ALLOY
4. LEAD FINISH: 100% MATTE Sn
5. INDICATED DIMENSION/TOLERANCE APPLIES TO LEADS AND EXPOSED PAD

Recommended PCB Land Pattern

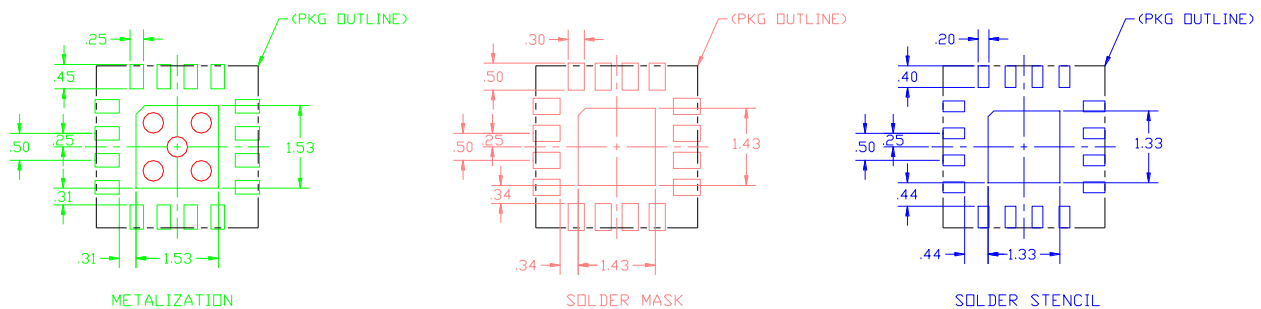



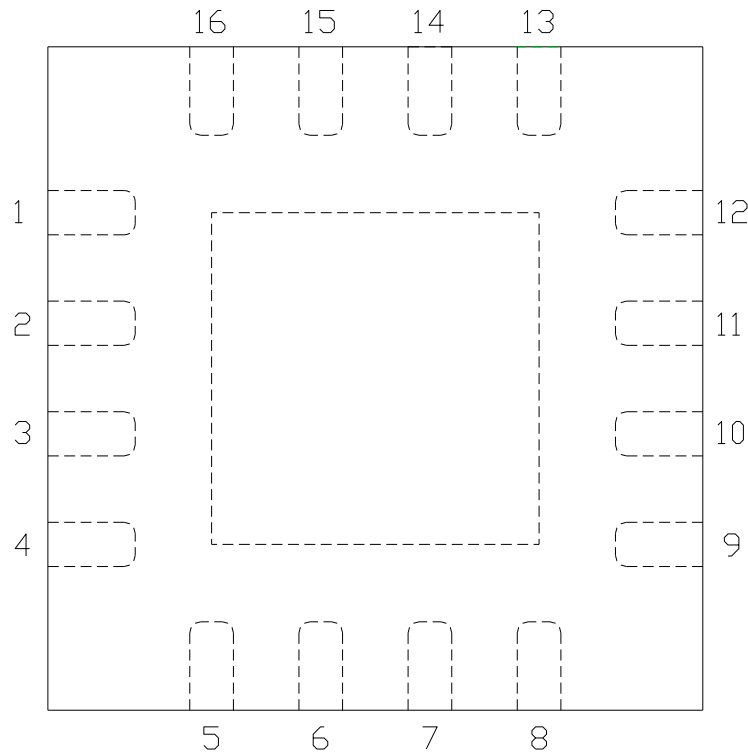

Pin Description

Pin Diagram

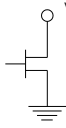

Functional Description

Pin	Function	Description	Schematic
2	RF in	DC blocked and 50 ohm matched	
11	RF out	DC blocked and 50 ohm matched	
14	Vdd	Power supply voltage Decoupling and bypass caps required	
3,10 and die paddle	Ground	Connect to RF / DC ground	

ver 1.2 0612

Applications Information

Application Circuit

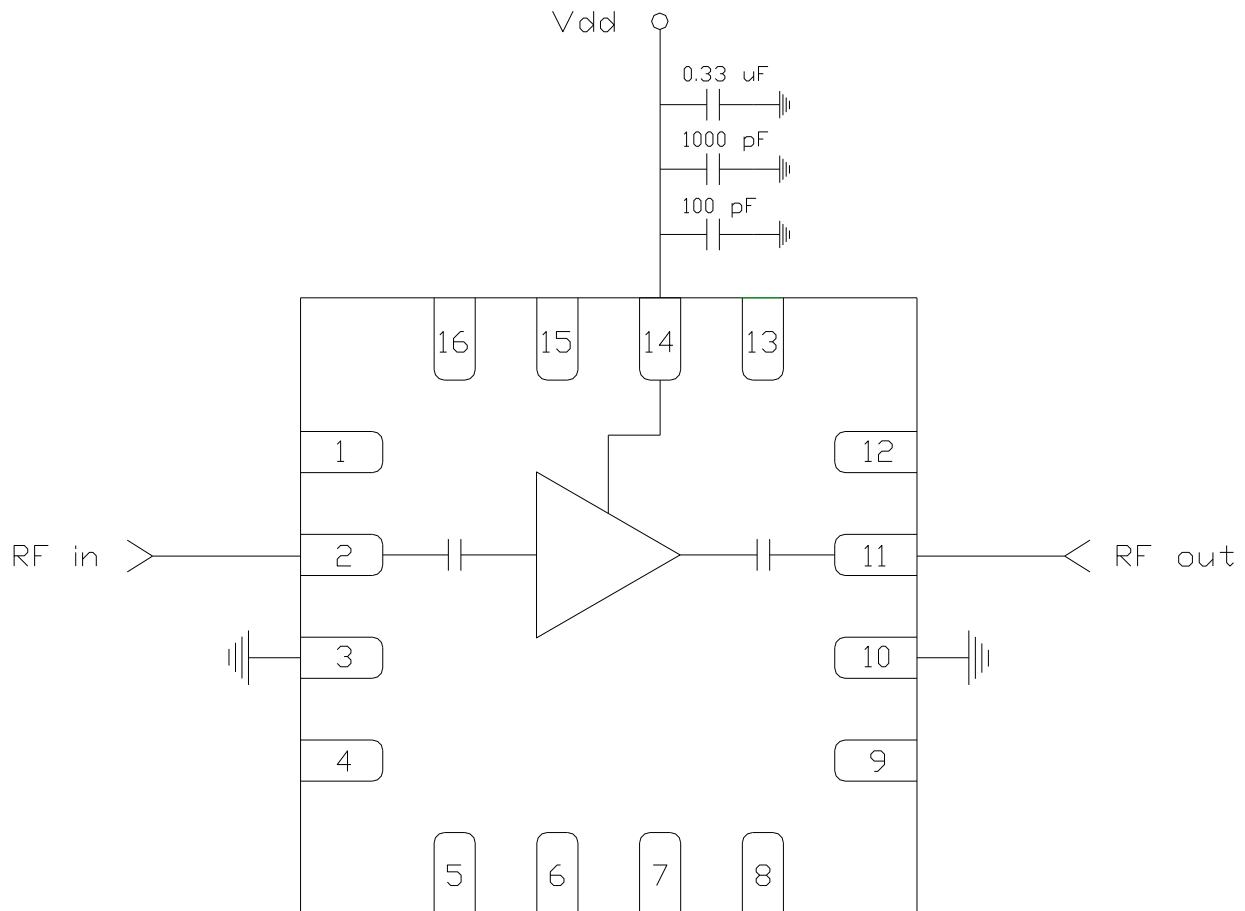

Biasing and Operation

The CMD119P3 is biased with a single 3.6 V positive drain supply.

RF power can be applied at any time.

GaAs MMIC devices are susceptible to damage from Electrostatic Discharge. Proper precautions should be observed during handling, assembly and test.

ver 1.2 0612

Applications Information

Evaluation Board

The circuit board shown has been developed for optimized assembly at CMDS. A sufficient number of via holes should be used to connect the top and bottom ground planes. As surface mount processes vary, careful process development is recommended.

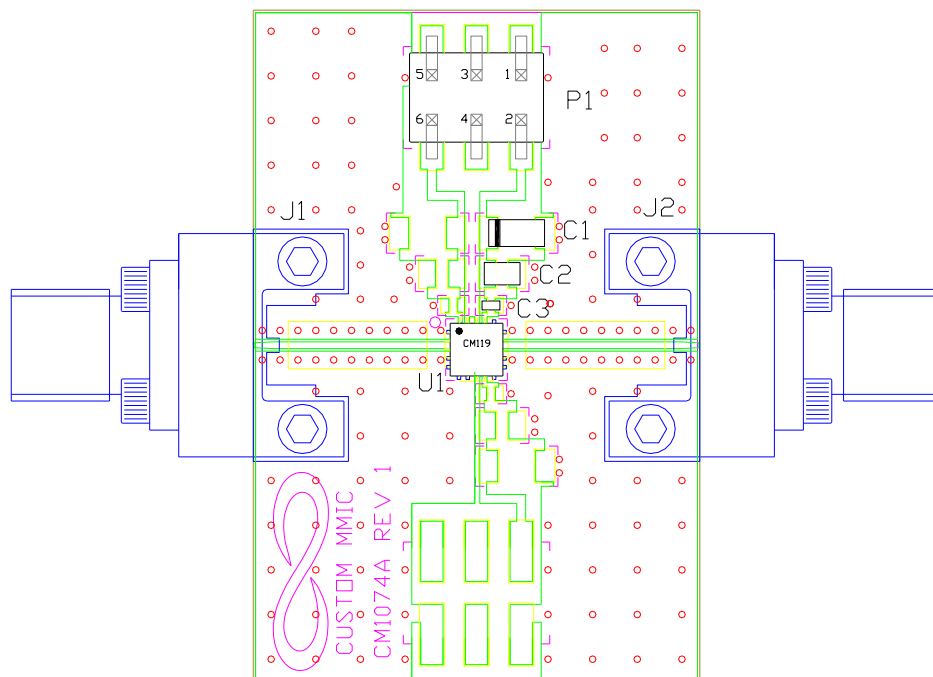
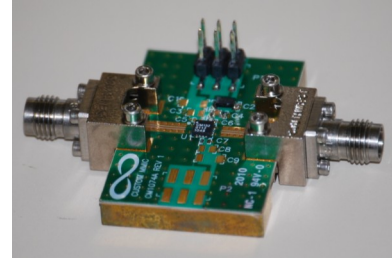

Bill of Material

Designator	Value	Description
J1, J2		2.4 mm End Launch Connector
P1		10 Pin Header
C1	0.33 μ F	Capacitor, Tantalum
C2	1000 pF	Capacitor, 0603
C3	100 pF	Capacitor, 0402
U1		CMD119P3 Low Noise Amplifier
PCB		CM1074A Evaluation PCB

ver 1.2 0612