

HIGH STABILITY MINIATURE OCXO MV333

Features:

- Small package – 1”x1”x0.5” (25x25x12.7 mm)
- Long term stability up to $\pm 2 \times 10^{-8}$ /year
- Available as RoHS
- Standard frequency 10.0 MHz

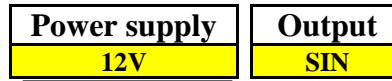

ORDERING GUIDE: MV333 – C 5 F – 12V – SIN – 10.0 MHz - 4

Availability of certain stability vs. operating temperature range		$\pm 1.5 \times 10^{-8}$	$\pm 1 \times 10^{-8}$	$\pm 5 \times 10^{-9}$
		15	10	5
A	0...+55 °C	A	A	A
B	-10...+60 °C	A	A	A
C	- 20...+70 °C	A	A	C
D	- 40...+70 °C	A	A	C
EX	- 40...+85 °C	A	A	C

A – available, NA – not available, C – consult factory

For other temperature ranges see designation at the end of Data Sheet.

Package drawing:

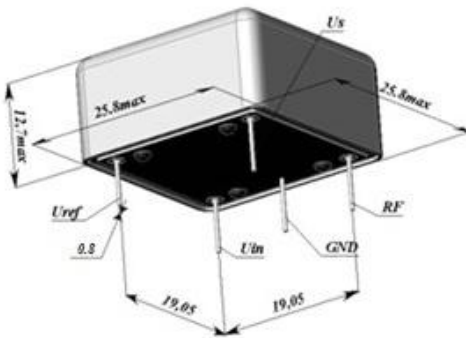

Availability of certain aging values for certain frequencies		Standard frequencies
		10.0 MHz
G	$\pm 1 \times 10^{-7}$ / year	A
F	$\pm 5 \times 10^{-8}$ / year	A
E	$\pm 3 \times 10^{-8}$ / year	A

A – available, NA – not available, C – consult factory

Phase noise, dBc/Hz, for 10MHz, SIN	1	2	3	4
1 Hz	<-95	<-98	<-90	<-95
10 Hz	<-125	<-130	<-125	<-125
100 Hz	<-155	<-158	<-158	<-158
1000 Hz	<-165	<-165	<-168	<-168
10000 Hz	<-170	<-170	<-174	<-174

Vibrations:	
Frequency range	10-500 Hz
Acceleration	5 g

Shock:	
Acceleration	75 g
Duration	3±1 ms

Humidity @ 25 °C	98%
Storage temperature range	-55...+85 °C

Short term stability (Allan deviation) per 1 sec, for 10 MHz	$< 5 \times 10^{-12}$
Frequency stability vs. load changes (±5%)	$< \pm 5 \times 10^{-10}$
Frequency stability vs. power supply changes (±5%)	$< \pm 5 \times 10^{-10}$
Warm-up time within accuracy of $\pm 2 \times 10^{-8}$ @ 25 °C	<5 min
Power supply (Us)	12V±5%
Steady state current consumption @ 25°C	<170 mA
Peak current consumption during warm-up (for “B” temp. range)	<500 mA
Frequency pulling range (for 10 MHz)	$> \pm 4.0 \times 10^{-7}$
Control voltage range (Uin)	0...5 V
Reference voltage (Uref)	+5 V
Output	SIN
Level	>600 mV RMS
Load	50 Ohm±5%
Harmonics	>30 dBc

Additional notes:

- Please consult factory for daily aging values. Normally typical correspondence of daily to aging per year is as following: $\pm 1 \times 10^{-7}$ /year – $\pm 1 \times 10^{-9}$ /day; $\pm 5 \times 10^{-8}$ /year – $\pm 5 \times 10^{-10}$ /day; $\pm 3 \times 10^{-8}$ /year – $\pm 3 \times 10^{-10}$ /day
- Please mention RoHS requirement (if any) while requesting for quote or while placing PO.
- For non standard operating temperature ranges please use the following two letters designations (first letter for the lower limit, second letter for the upper limit), °C:

A	B	C	D	E	F	G	H	J	K	L	M	N	P	Q	R	S	T	U	W	X
-60	-55	-50	-45	-40	-30	-20	-10	0	+10	+30	+40	+45	+50	+55	+60	+65	+70	+75	+80	+85