

REVISIONS				
ZONE	REV	DESCRIPTION	DATE	APPROVED

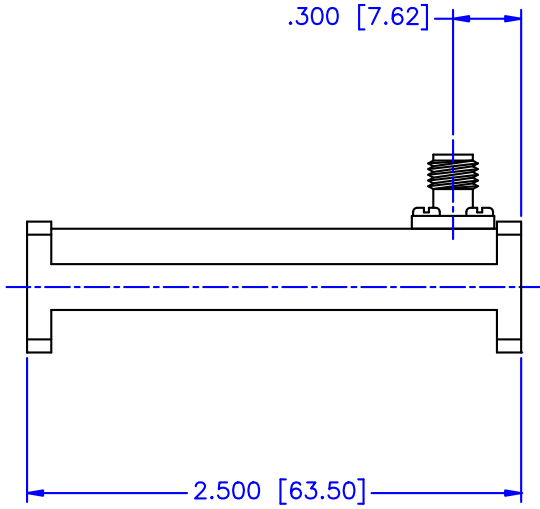
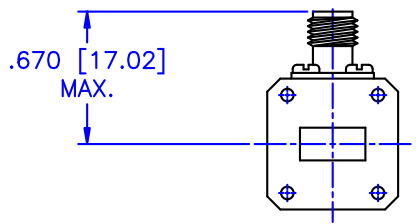

**SPECIFICATIONS:**

- Frequency Range: 27–32 GHz
- Nominal Coupling: 30±0.5dB
- Frequency Sensitivity: ±0.5dB
- Flatness: ±0.75dB
- VSWR Primary: 1.05:1 Max.
- VSWR Coaxial: 1.25:1 Max.
- Directivity: 25dB Min.
- Connector Type: SMA Female
- Flange Type: UG–COVER

- \* Aluminum body
- \* Finishing: Corrosion–resistance 316 stainless steel epoxy coating

MATERIAL:			MICROWAVE COMMUNICATIONS LABORATORIES INC. 7255 30TH AVE. N. SAINT PETERSBURG, FL 33710 TEL: (727) 344–6254 FAX: (727) 381–6116 http://WWW.MCLI.COM		SCALE:	N/A
			UNLESS OTHERWISE SPECIFIED: TOLERANCES IN (INCHES) OR [mm] (MILLIMETERS) FRACTIONS: ± 1/64 DECIMALS: ±.01 ±.005 ANGLE: ±1/2°		DRAWING TITLE:	WAVEGUIDE, COUPLER
DRAWN:	DATE:	PROPRIETARY NOTICE: THE INFORMATION IN THIS DRAWING IS PROPRIETARY AND SHALL NOT BE USED OR DISCLOSED WITHOUT WRITTEN PERMISSION FROM MICROWAVE COMMUNICATIONS LABORATORIES INC. (MCLI)	PART NO.		WGL13–30–S–2	
APPROVED:	DATE:		CAGE CODE:	SIZE:	REV:	DWG NO.
Pai boon Luexhamhan	04–03–2008	THIRD ANGLE PROJECTION 	OD2L5	A	N/A	82821
T. Nguyen	04–03–2008		DO NOT SCALE THE DRAWING			