

Features

- 16 dB Gain at 900 MHz
- 32.7 dBm P1dB at 900 MHz
- 49 dBm Output IP3 at 900 MHz
- MTTF > 100 Years
- Single Supply

Description

The ASX601, a power amplifier MMIC, has a high linearity, high gain, and high efficiency over a wide range of frequency, being suitable for use in both receiver and transmitter of telecommunication systems up to 2.5 GHz. The amplifier is available in a SOT89 package and passes through the stringent DC, RF, and reliability tests.



Package Style: SOT89

Typical Performance

(Supply Voltage = Device Voltage, $T_A = +25\text{ }^\circ\text{C}$, $Z_0 = 50\ \Omega$)

Parameters	Units	Typical		Typical	
		900	2000	900	2000
Frequency	MHz	900	2000	900	2000
Gain	dB	16.0	9.5	16.0	9.5
S11	dB	-18	-14	-18	-14
S22	dB	-14	-12	-14	-12
Output IP3 ¹⁾	dBm	49	47	44	43
Noise Figure	dB	5.6	5.8	5.6	5.8
Output P1dB	dBm	32.7	31.0	32.0	31.0
Current	mA	850	850	710	710
Device Voltage	V	+5	+5	+4.7	+4.7

1) OIP3 measured with two tones at an output power of +15 dBm/tone separated by 1 MHz.

Product Specifications

Parameters	Units	Min	Typ	Max
Testing Frequency	MHz		900	
Gain	dB	15.0	16.0	
S11	dB		-18	
S22	dB		-14	
Output IP3	dBm	47	49	
Noise Figure	dB		5.6	5.9
Output P1dB	dBm	32.0	32.7	
Current	mA	820	850	900
Device Voltage	V		+5	

Absolute Maximum Ratings

Parameters	Rating
Operating Case Temperature	-40 to +85 °C
Storage Temperature	-40 to +150 °C
Device Voltage	+6 V
Operating Junction Temperature	+150 °C
Input RF Power (CW, 50 Ω matched) ¹⁾	+25 dBm
Thermal Resistance	14 °C/W

1) Please find the max. input power data from http://www.asb.co.kr/pdf/Maximum_Input_Power_Analysis.pdf

Application Circuit

- IF (350 MHz)
- IF (440 ~ 460 MHz)
- Others (715 ~ 725 MHz)
- CDMA
- RFID (USA)
- GSM
- Others (1400 ~ 1500 MHz)

Pin Configuration

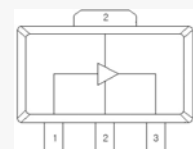

Pin No.	Function
1	RF IN
2	GND
3	RF OUT / Bias

Outline Drawing

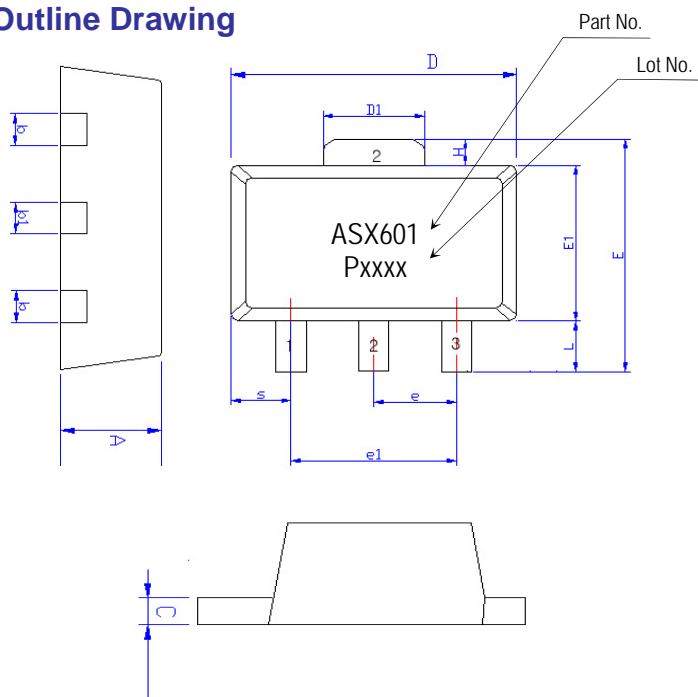

Symbols	Dimensions (In mm)		
	MIN	NOM	MAX
A	1.40	1.50	1.60
L	0.89	1.04	1.20
b	0.36	0.42	0.48
b1	0.41	0.47	0.53
C	0.38	0.40	0.43
D	4.40	4.50	4.60
D1	1.40	1.60	1.75
E	3.64	---	4.25
E1	2.40	2.50	2.60
e1	2.90	3.00	3.10
H	0.35	0.40	0.45
S	0.65	0.75	0.85
e	1.40	1.50	1.60

Pin No.	Function
1	RF IN
2	GND
3	RF OUT / Bias

Mounting Recommendation (In mm)

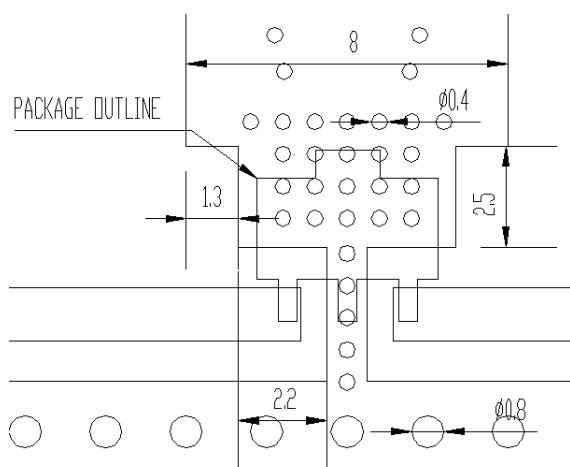

- Note:**
1. The number and size of ground via holes in a circuit board is critical for thermal and RF grounding considerations.
 2. We recommend that the ground via holes be placed on the bottom of the lead pin 2 and exposed pad of the device for better RF and thermal performance, as shown in the drawing at the left side.

ESD Classification & Moisture Sensitivity Level

ESD Classification

HBM	Class 1B Voltage Level: 500 V ~ 1000 V
MM	Class A Voltage Level: < 200 V

CAUTION: ESD-sensitive device!

Moisture Sensitivity Level (MSL)

Level 3 at 260 °C reflow

APPLICATION CIRCUIT

IF

350 MHz

+5 V

Frequency (MHz)	350
Magnitude S21 (dB)	20.5
Magnitude S11 (dB)	-14
Magnitude S22 (dB)	-12
Output P1dB (dBm)	33
Output IP3 ¹⁾ (dBm)	46
Noise Figure (dB)	7.4
Device Voltage (V)	+5
Current (mA)	850

1) OIP3 is measured with two tones at an output power of +15 dBm/tone separated by 1 MHz.

Schematic

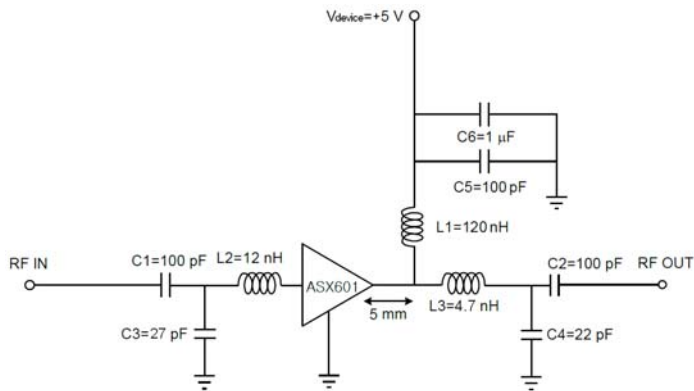

Board Layout (FR4, 40x40 mm², 0.8T)

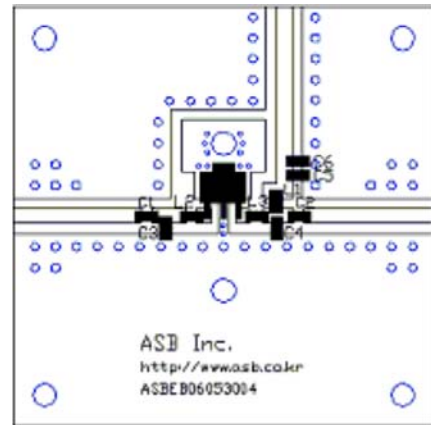

S-parameters & K-factor

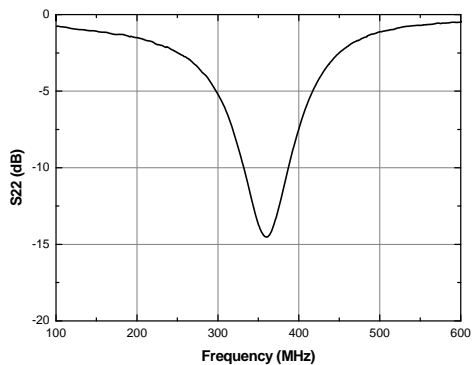
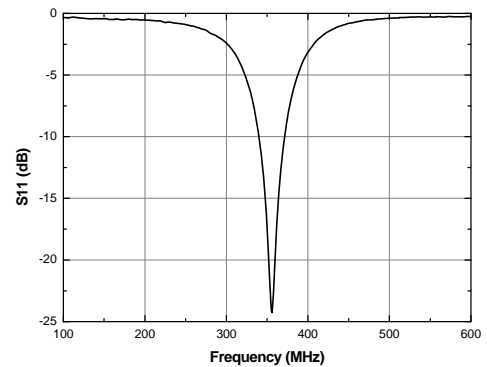
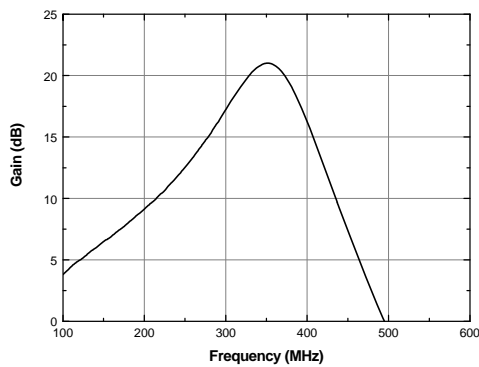

APPLICATION CIRCUIT

IF

440 ~ 460 MHz

+5 V

Frequency (MHz)	440 ~ 460
Magnitude S21 (dB)	19.5
Magnitude S11 (dB)	-13
Magnitude S22 (dB)	-18
Output P1dB (dBm)	34
Output IP3 ¹⁾ (dBm)	47
Noise Figure (dB)	6.8
Device Voltage (V)	+5
Current (mA)	850

1) OIP3 is measured with two tones at an output power of +15 dBm/tone separated by 1 MHz.

Schematic

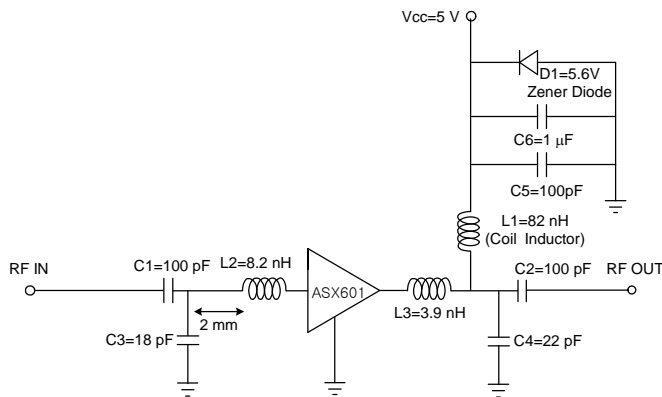

Board Layout (FR4, 40x40 mm², 0.8T)

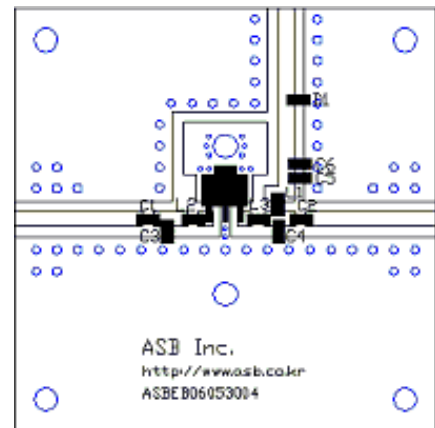

S-parameters & K-factor

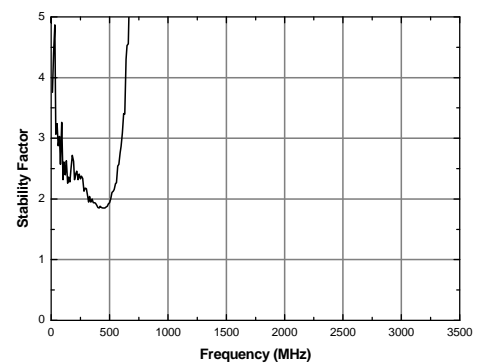
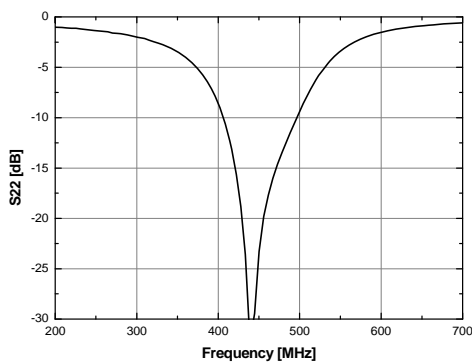
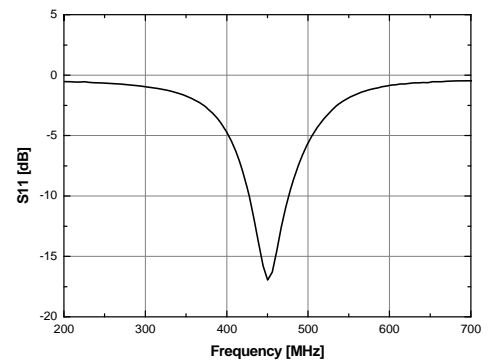
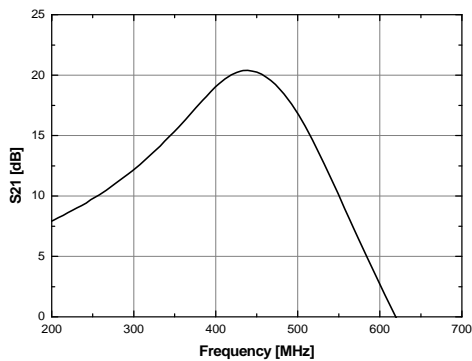

APPLICATION CIRCUIT

Others

715 ~ 725 MHz

+5 V

Frequency (MHz)	715 ~ 725
Magnitude S21 (dB)	18.0
Magnitude S11 (dB)	-18
Magnitude S22 (dB)	-15
Output P1dB (dBm)	34
Output IP3 ¹⁾ (dBm)	46
Noise Figure (dB)	5.8
Device Voltage (V)	+5
Current (mA)	850

1) OIP3 is measured with two tones at an output power of +18 dBm/tone separated by 1 MHz.

Schematic

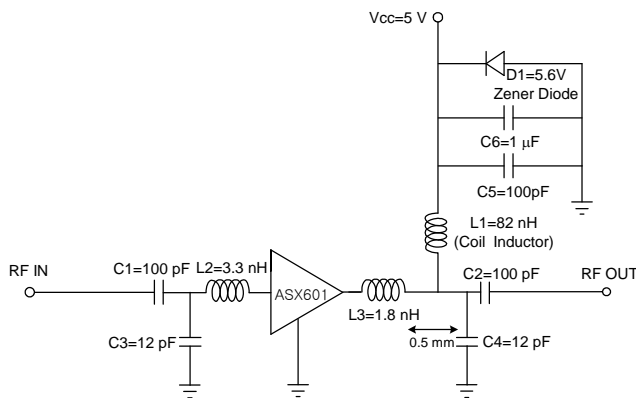

Board Layout (FR4, 40x40 mm², 0.8T)

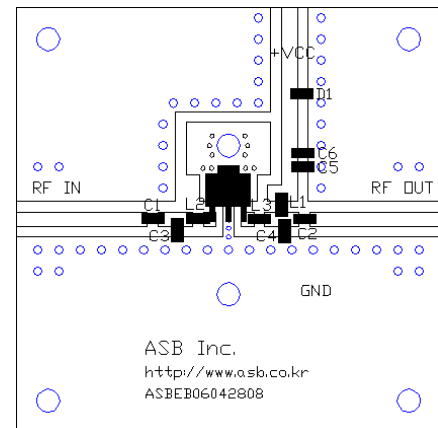

S-parameters & K-factor

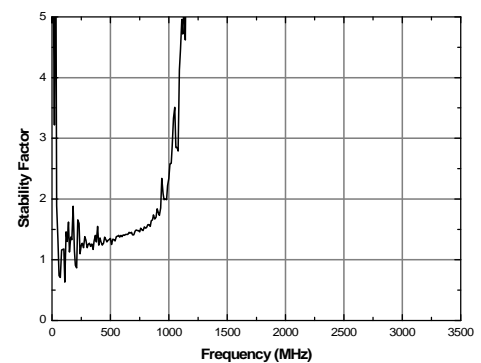
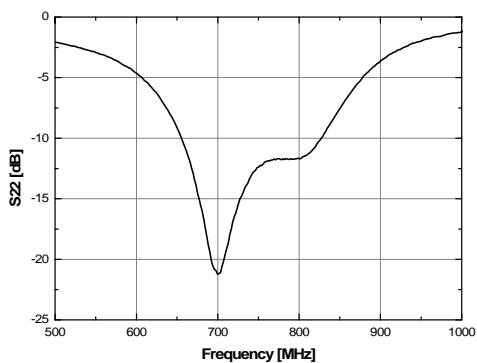
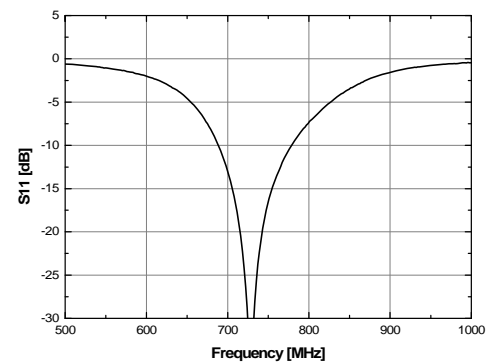
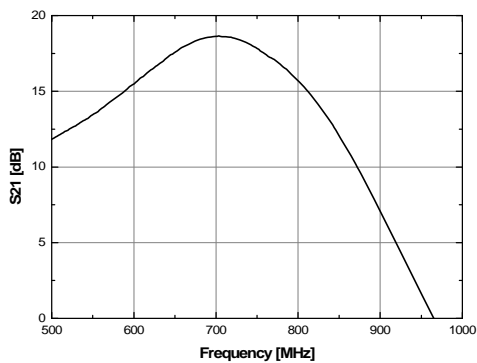

APPLICATION CIRCUIT

CDMA Rx

824 ~ 849 MHz

+5 V

Frequency (MHz)	824 ~ 849
Magnitude S21 (dB)	17.0
Magnitude S11 (dB)	-14
Magnitude S22 (dB)	-18
Output P1dB (dBm)	33
Output IP3 ¹⁾ (dBm)	48
Noise Figure (dB)	5.3
Device Voltage (V)	+5
Current (mA)	850

1) OIP3 is measured with two tones at an output power of +14 dBm/tone separated by 1 MHz.

Schematic

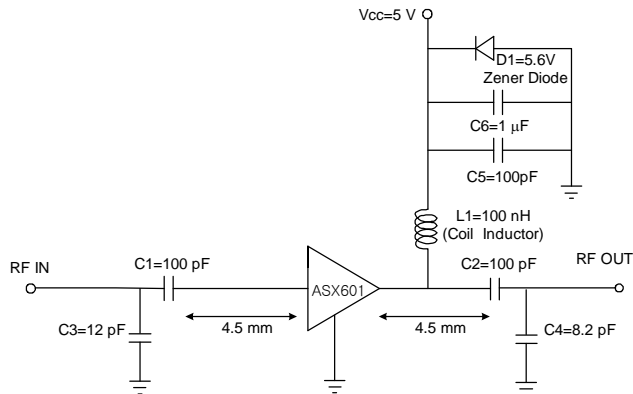

Board Layout (FR4, 40x40 mm², 0.8T)

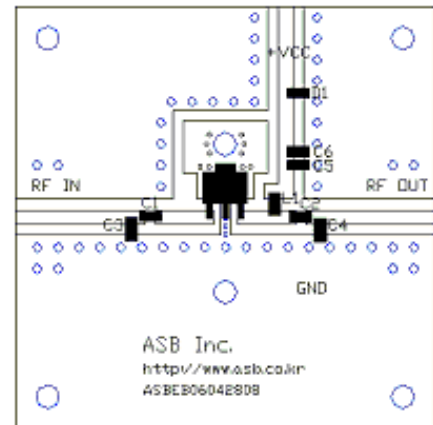

S-parameters & K-factor

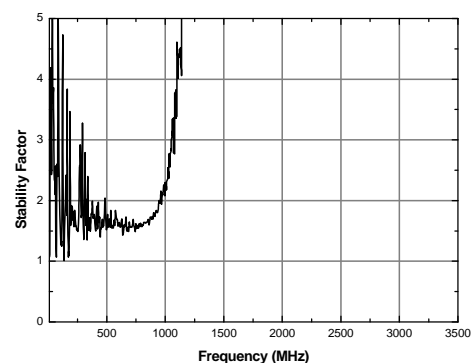
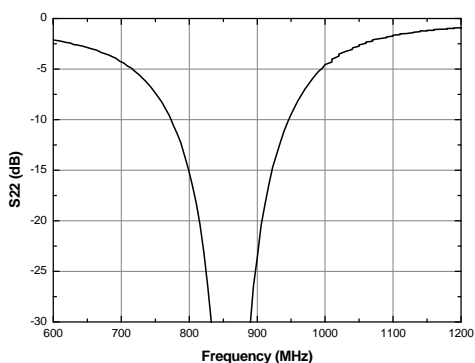
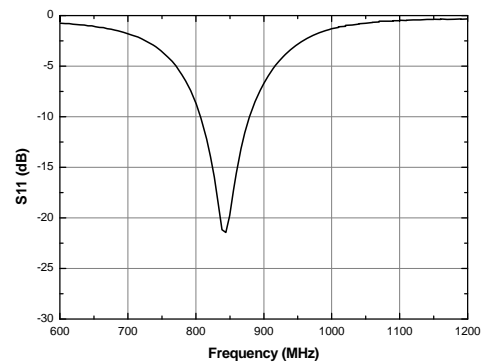
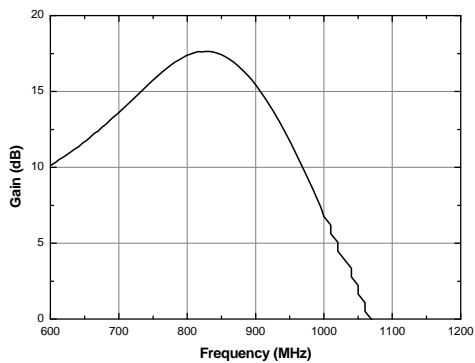

APPLICATION CIRCUIT

CDMA Tx

869 ~ 894 MHz

+5 V

Frequency (MHz)	869 ~ 894
Magnitude S21 (dB)	16.5
Magnitude S11 (dB)	-17
Magnitude S22 (dB)	-18
Output P1dB (dBm)	33
Output IP3 ¹⁾ (dBm)	48
Noise Figure (dB)	5.6
Device Voltage (V)	+5
Current (mA)	850

1) OIP3 is measured with two tones at an output power of +14 dBm/tone separated by 1 MHz.

Schematic

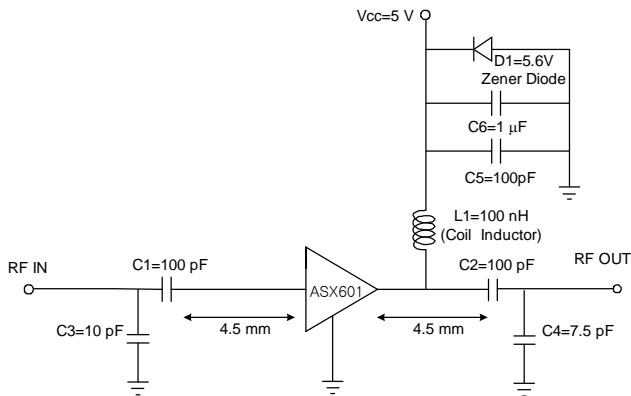

Board Layout (FR4, 40x40 mm², 0.8T)

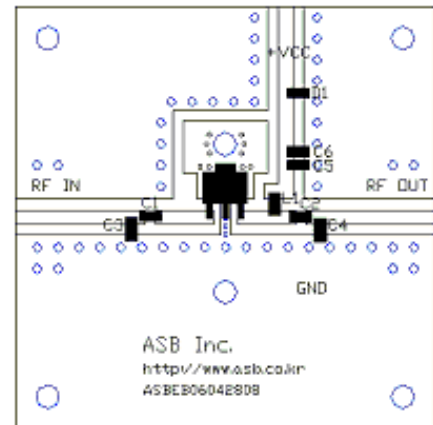

S-parameters & K-factor

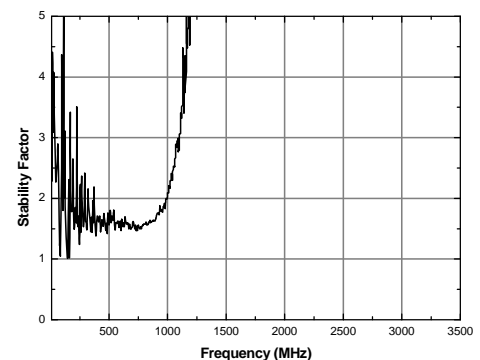
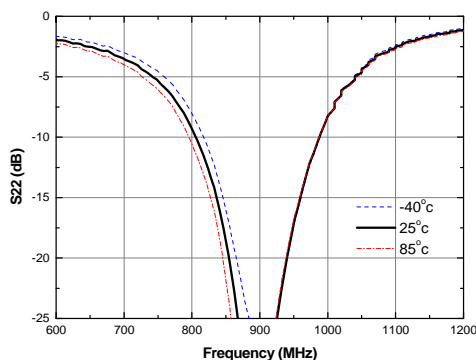
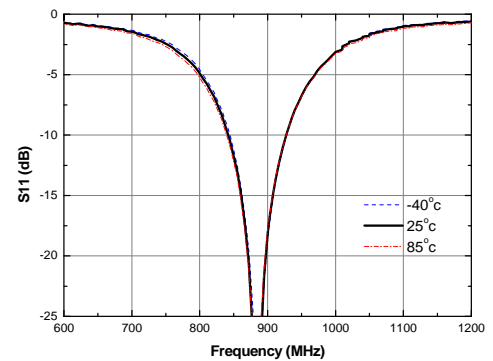
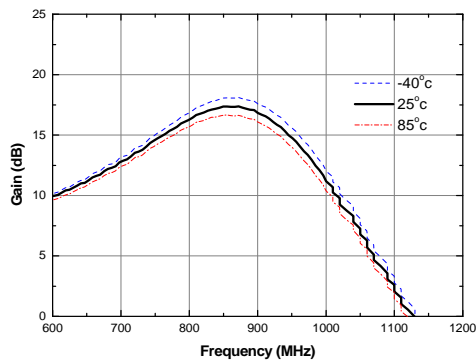

Current vs. Temperature

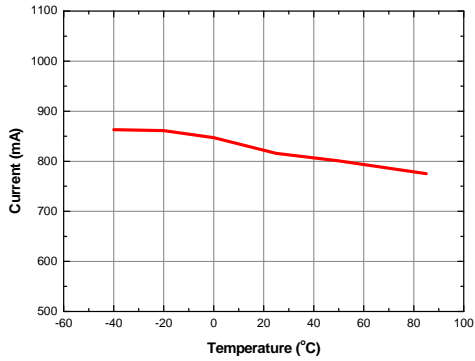

Gain vs. Temperature

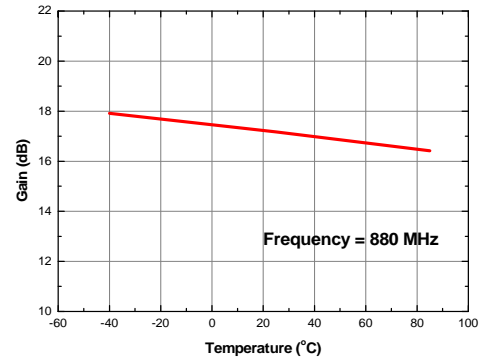

P1dB vs. Temperature

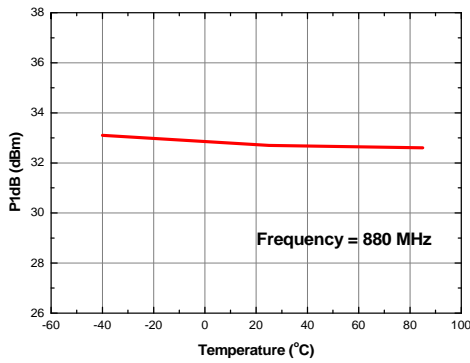

Output IP3 vs. Tone Power (Frequency = 880 MHz)

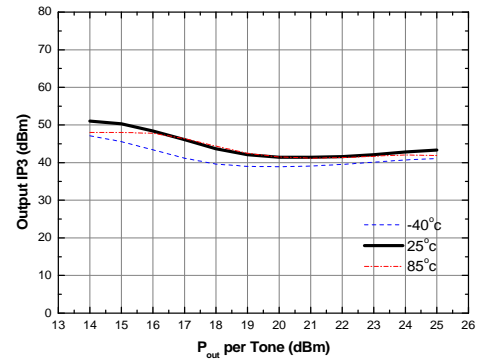

APPLICATION CIRCUIT

RFID (USA)

902 ~ 928 MHz

+5 V

Frequency (MHz)	902 ~ 928
Magnitude S21 (dB)	16.0
Magnitude S11 (dB)	-18
Magnitude S22 (dB)	-15
Output P1dB (dBm)	32.7
Output IP3 ¹⁾ (dBm)	48
Noise Figure (dB)	5.5
Device Voltage (V)	+5
Current (mA)	850

1) OIP3 is measured with two tones at an output power of +15 dBm/tone separated by 1 MHz.

Schematic

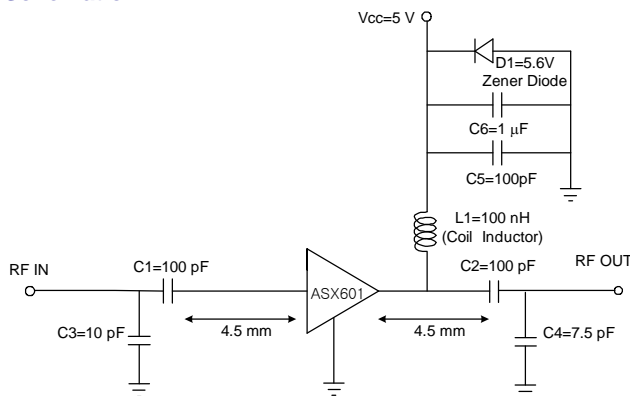

Board Layout (FR4, 40x40 mm², 0.8T)

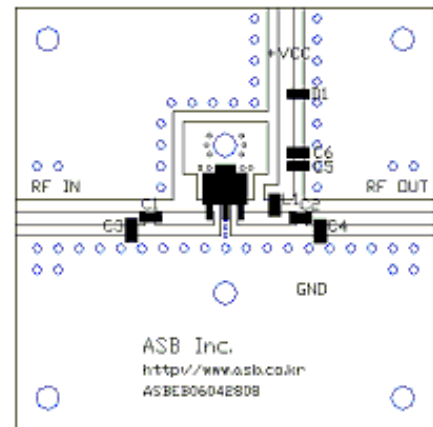

S-parameters & K-factor

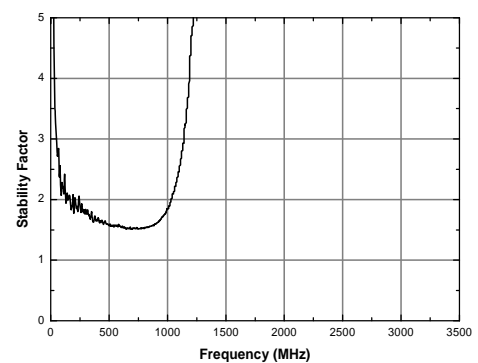
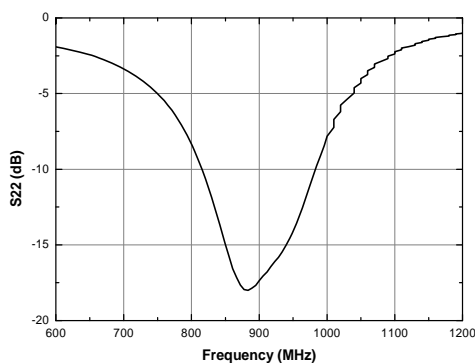
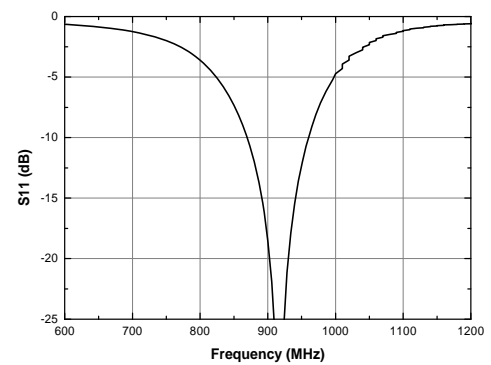
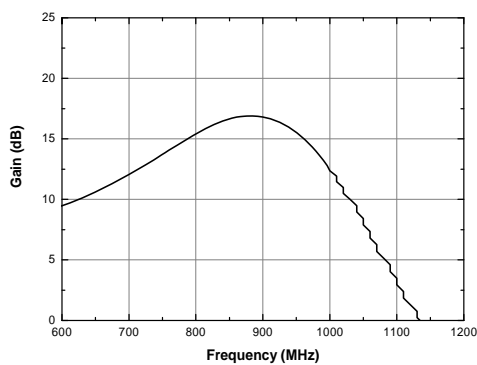

APPLICATION CIRCUIT

GSM Rx

890 ~ 915 MHz

+5 V

Frequency (MHz)	890 ~ 915
Magnitude S21 (dB)	16.0
Magnitude S11 (dB)	-18
Magnitude S22 (dB)	-14
Output P1dB (dBm)	32.7
Output IP3 ¹⁾ (dBm)	49
Noise Figure (dB)	5.6
Device Voltage (V)	+5
Current (mA)	850

1) OIP3 is measured with two tones at an output power of +15 dBm/tone separated by 1 MHz.

Schematic

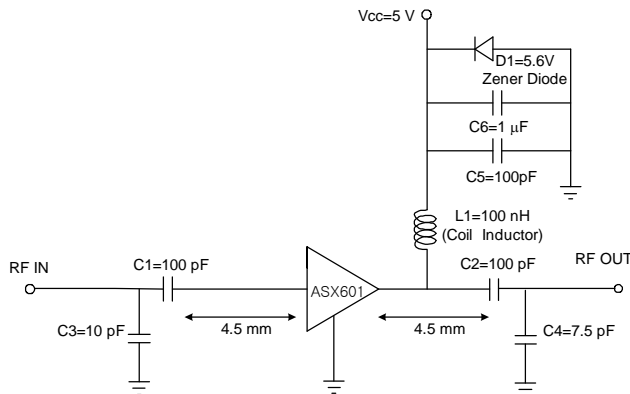

Board Layout (FR4, 40x40 mm², 0.8T)

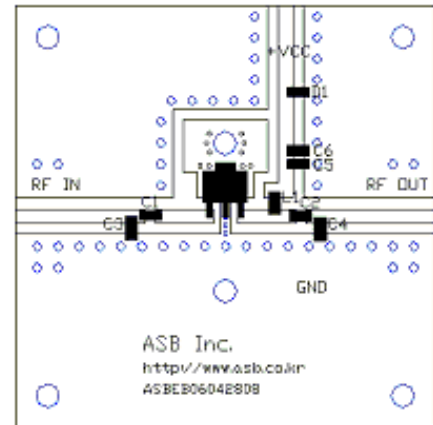

S-parameters & K-factor

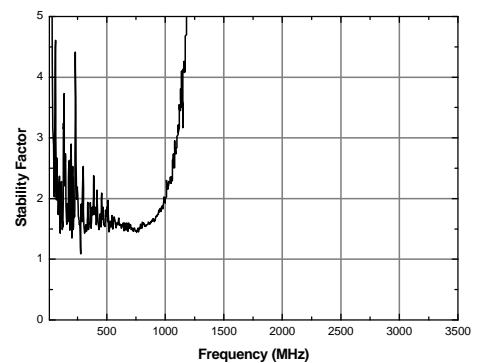
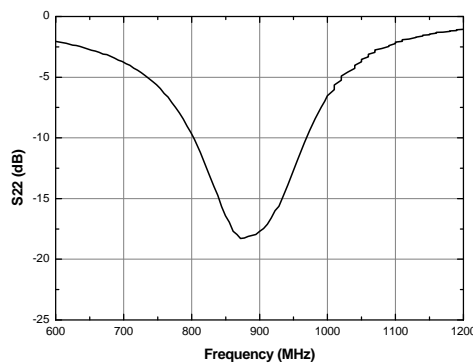
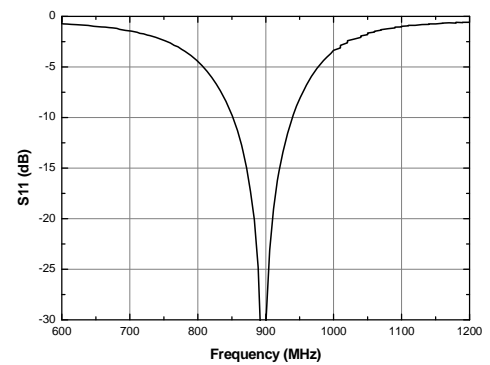
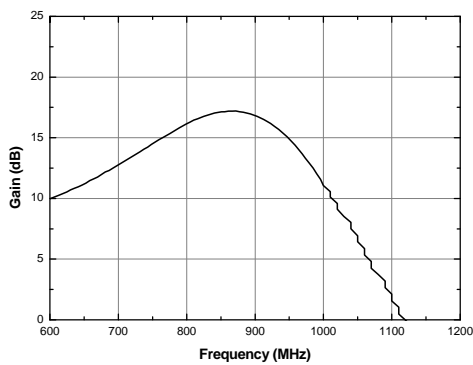

APPLICATION CIRCUIT

GSM Tx

935 ~ 960 MHz

+5 V

Frequency (MHz)	935 ~ 960
Magnitude S21 (dB)	16.0
Magnitude S11 (dB)	-15
Magnitude S22 (dB)	-12
Output P1dB (dBm)	34
Output IP3 ¹⁾ (dBm)	49
Noise Figure (dB)	5.5
Device Voltage (V)	+5
Current (mA)	850

1) OIP3 is measured with two tones at an output power of +15 dBm/tone separated by 1 MHz.

Schematic

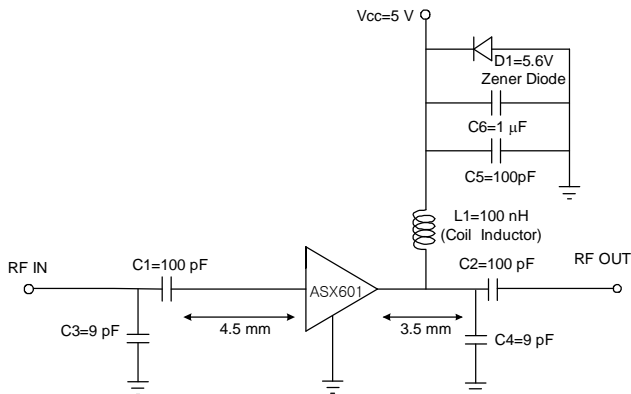

Board Layout (FR4, 40x40 mm², 0.8T)

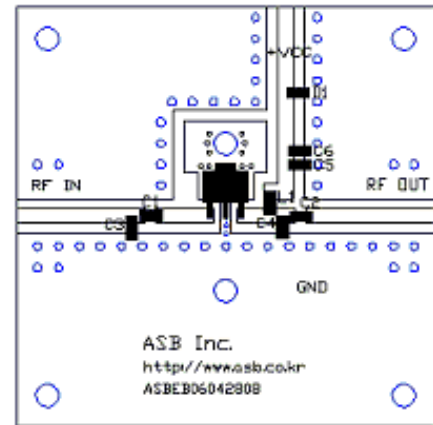

S-parameters & K-factor

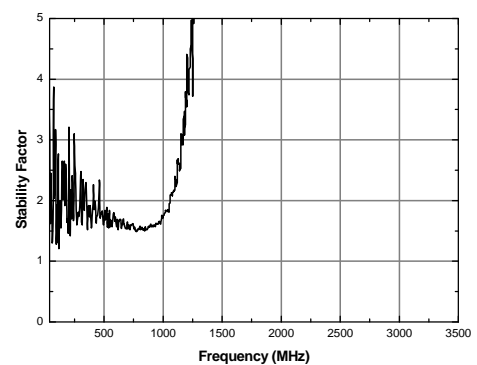
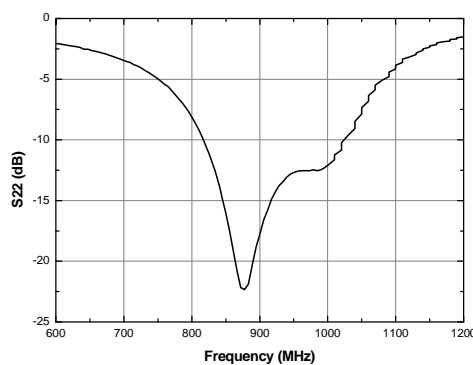
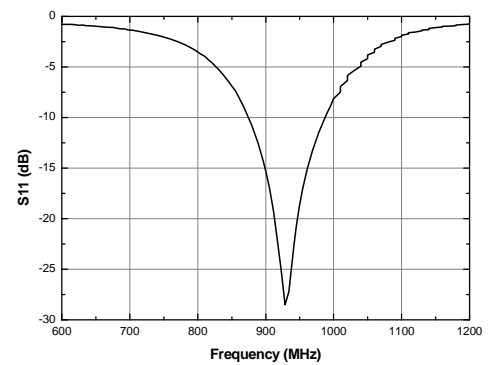
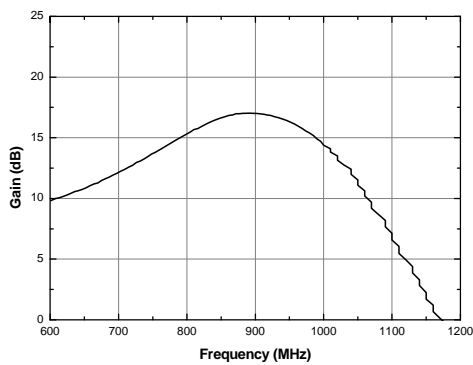

APPLICATION CIRCUIT

Others

1400 ~ 1500 MHz

+5 V

Frequency (MHz)	1400	1500
Magnitude S21 (dB)	13.5	12.5
Magnitude S11 (dB)	-13	-12
Magnitude S22 (dB)	-18	-18
Output P1dB (dBm)	32.0	32.5
Output IP3 ¹⁾ (dBm)	48.5	48.5
Noise Figure (dB)	5.5	5.5
Device Voltage (V)	+5	+5
Current (mA)	850	850

1) OIP3 is measured with two tones at an output power of +14 dBm/tone separated by 1 MHz.

Schematic

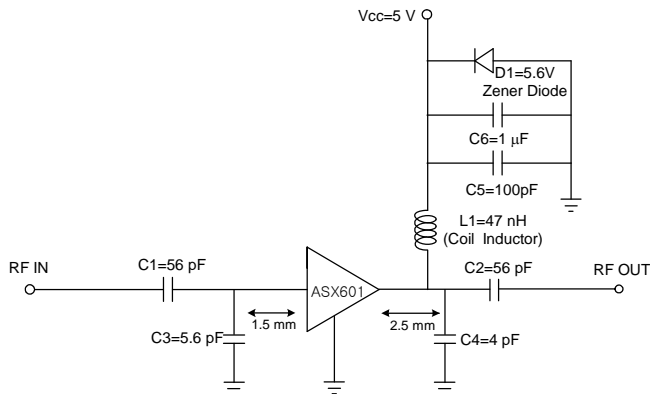

Board Layout (FR4, 40x40 mm², 0.8T)

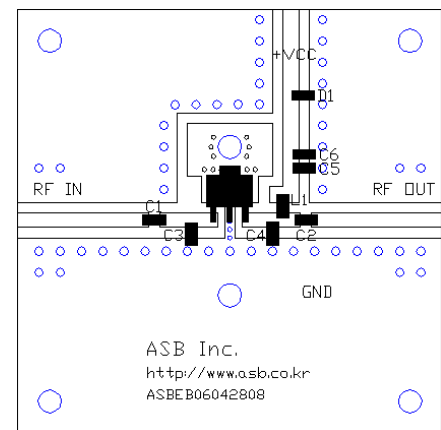

S-parameters & K-factor

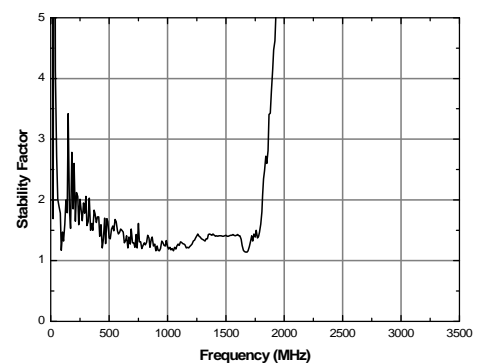
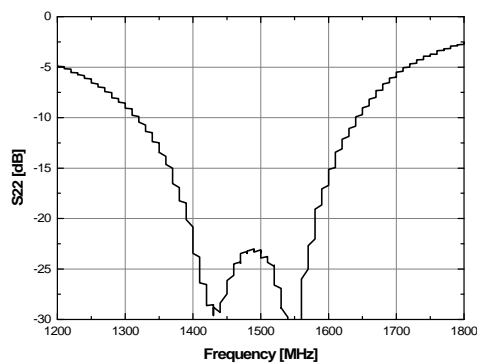
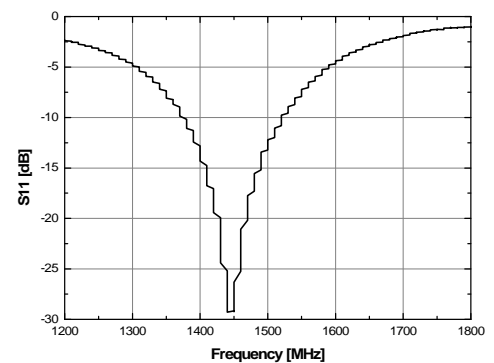
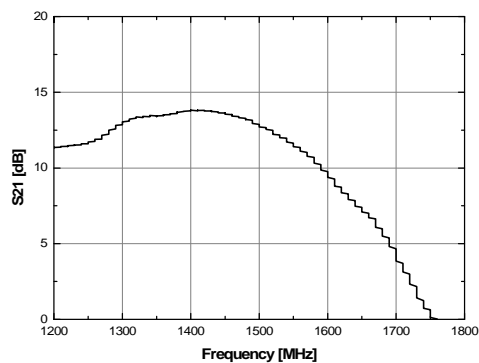

APPLICATION CIRCUIT

PCS Rx

1750 ~ 1780 MHz

+5 V

Frequency (MHz)	1750 ~ 1780
Magnitude S21 (dB)	11.2
Magnitude S11 (dB)	-14
Magnitude S22 (dB)	-15
Output P1dB (dBm)	30
Output IP3 ¹⁾ (dBm)	47
Noise Figure (dB)	5.5
Device Voltage (V)	+5
Current (mA)	850

1) OIP3 is measured with two tones at an output power of +13 dBm/tone separated by 1 MHz.

Schematic

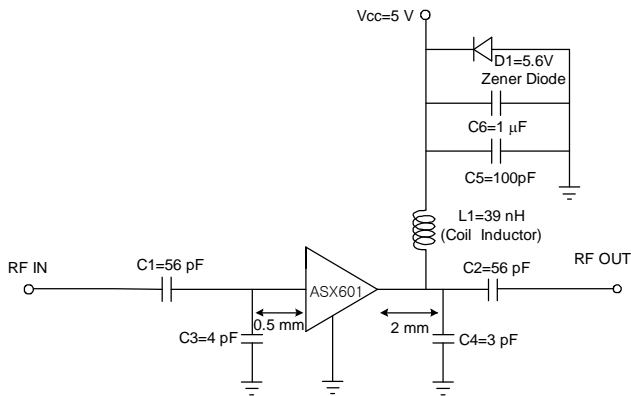

Board Layout (FR4, 40x40 mm², 0.8T)

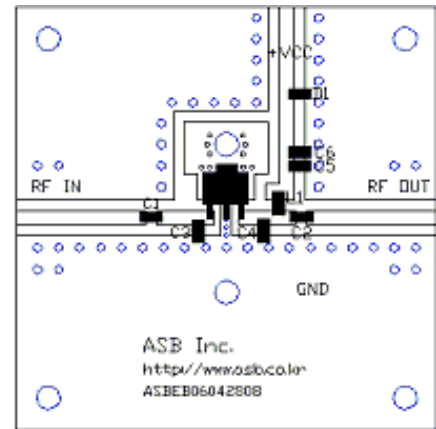

S-parameters & K-factor

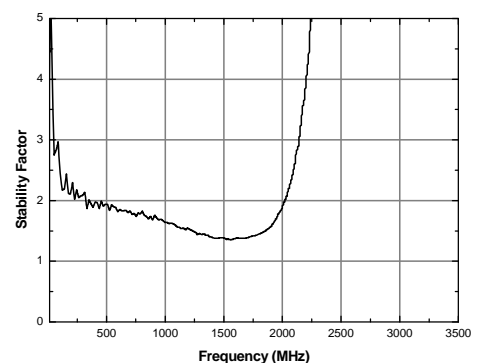
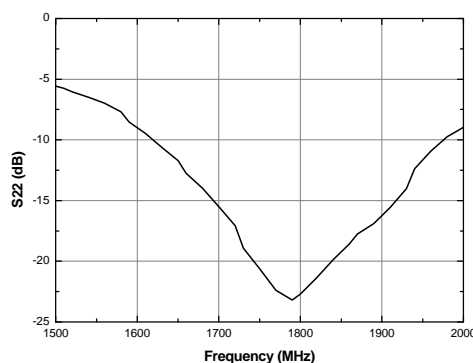
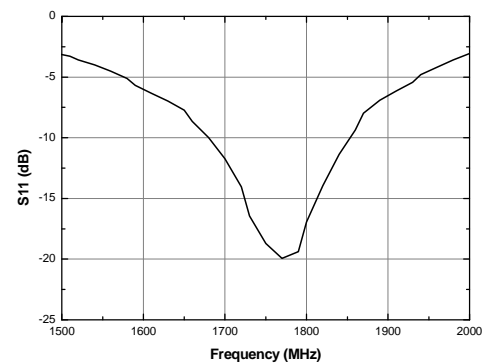
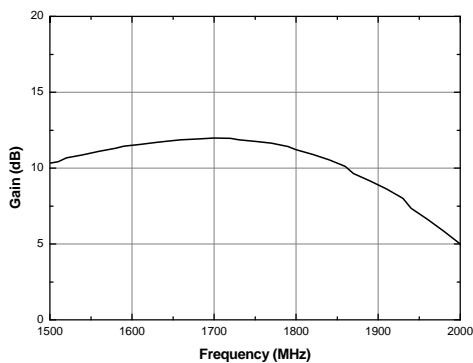

APPLICATION CIRCUIT

PCS Tx

1840 ~ 1870 MHz

+5 V

Frequency (MHz)	1840 ~ 1870
Magnitude S21 (dB)	10.3
Magnitude S11 (dB)	-16
Magnitude S22 (dB)	-17
Output P1dB (dBm)	29.5
Output IP3 ¹⁾ (dBm)	47
Noise Figure (dB)	5.7
Device Voltage (V)	+5
Current (mA)	850

1) OIP3 is measured with two tones at an output power of +13 dBm/tone separated by 1 MHz.

Schematic

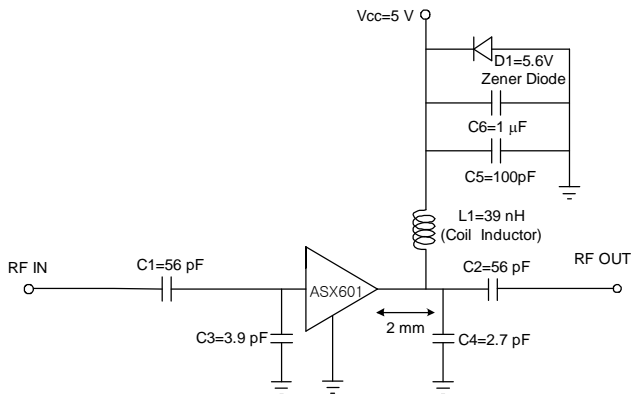

Board Layout (FR4, 40x40 mm², 0.8T)

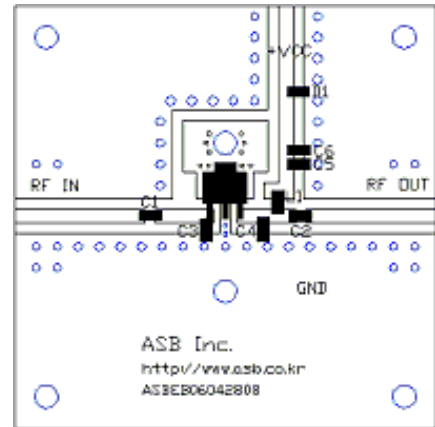

S-parameters & K-factor

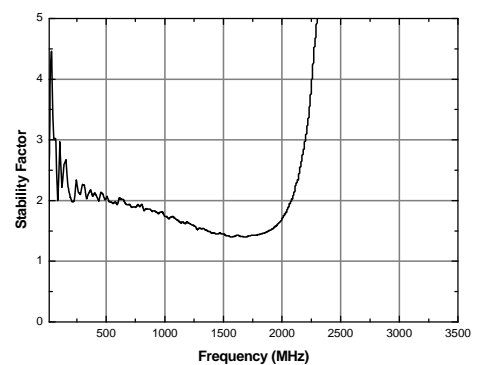
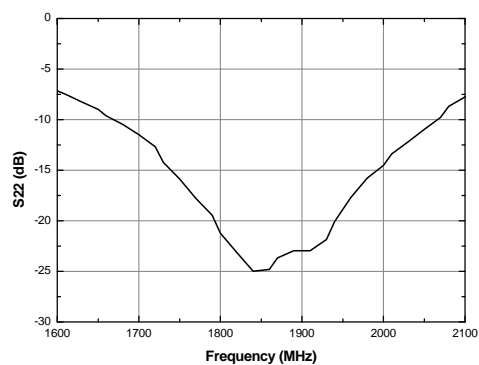
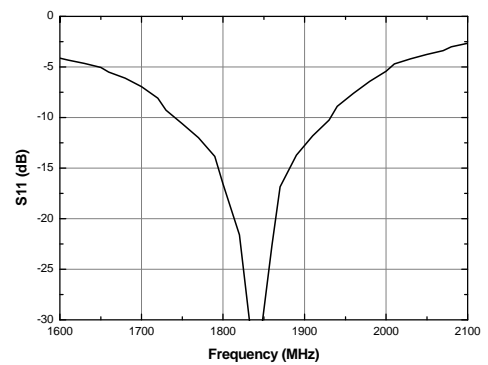
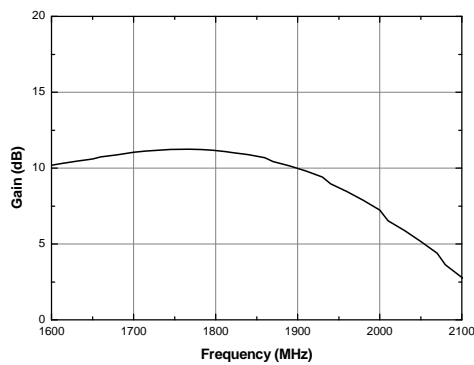

Recommended Soldering Reflow Profile

