

**SF2138B**

**144.132 MHz  
SAW Filter**

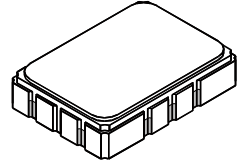

**SMP-03**

- **Designed for SDARS IF Receiver**
- **Low Insertion Loss**
- **5.0 x 7.0 mm Surface-mount Case**
- **Differential or Single-ended Input and Output**
- **Complies with Directive 2002/95/EC (RoHS)**



**Absolute Maximum Ratings**

Rating	Value	Units
Maximum Incident Power in Passband	+10	dBm
Maximum DC Voltage Between any Two Terminals	30	VDC
Storage Temperature Range in Tape and Reel	-40 to +85	°C
Maximum Soldering Profile	265 °C for 10 s	

**Electrical Characteristics**

Characteristic	Sym	Notes	Min	Typ	Max	Units
Nominal Center Frequency	$f_c$	1		144.132		MHz
Passband Width at +25 °C			137.882		150.382	dB
1 dB Bandwidth	$BW_1$	1	12.5	13.3		MHz
15 dB Bandwidth	$BW_{15}$			15.9	16.2	MHz
30 dB Bandwidth	$BW_{30}$			16.9	18.2	MHz
Passband Minimum Insertion Loss, Including Matching Network	$IL_{MIN}$			13.7	15.5	dB
Terminating Source Impedance			ZS = 200 ohms differential			
Terminating Load Impedance			ZL = 1.5K ohms differential			
Amplitude Ripple:						dB <sub>p-p</sub>
TDM1, 137.882 to 142.382 MHz				1	1.7	
COFDM, 141.882 to 146.182 MHz				0.5	1.5	
TDM2, 145.882 to 150.382 MHz				1	1.7	
Attenuation Relative to Insertion Loss at Center Frequency:		1, 3				dBc
122.882 to 127.882 MHz			45	50		
127.882 to 132.882 MHz			43	47		
154.137 to 159.137 MHz			38	42		
159.137 to 162.882 MHz			43	47		
162.882 to 177.882 MHz			48	53		
Group Delay Ripple:						ns <sub>p-p</sub>
TDM1, 137.882 to 142.382 MHz				30	100	
COFDM, 141.882 to 146.182 MHz				25	100	
TDM2, 145.882 to 150.382 MHz				30	100	
Operating Temperature Range	$T_A$	1	-40		+85	°C
Case Style		6	SMP-03 7 x 5 mm Nominal Footprint			
Lid Symbolization, YY=year, WW=week, S=shift			RFM SF2138B YYWWS			

 **CAUTION: Electrostatic Sensitive Device. Observe precautions for handling.**

**NOTES:**

1. Unless noted otherwise, all specifications apply over the operating temperature range with filter soldered to the specified demonstration board with impedance matching to 50 Ω and measured with 50 Ω network analyzer.
2. Unless noted otherwise, all frequency specifications are referenced to the nominal center frequency,  $f_c$ .
3. Rejection is measured as attenuation below the minimum IL point in the passband. Rejection in final user application is dependent on PCB layout and external impedance matching design. See Application Note No. 42 for details.
4. "LRIP" or "L" after the part number indicates "low rate initial production" and "ENG" or "E" indicates "engineering prototypes."
5. The design, manufacturing process, and specifications of this filter are subject to change.
6. Tape and Reel Standard ANSI / EIA 481.
7. Either Port 1 or Port 2 may be used for either input or output in the design. However, impedances and impedance matching may vary between Port 1 and Port 2, so that the filter must always be installed in one direction per the circuit design.
8. US and international patents may apply.
9. Murata, stylized Murata logo, and Murata N.A., Inc. are registered trademarks of Murata Manufacturing Co., Ltd.

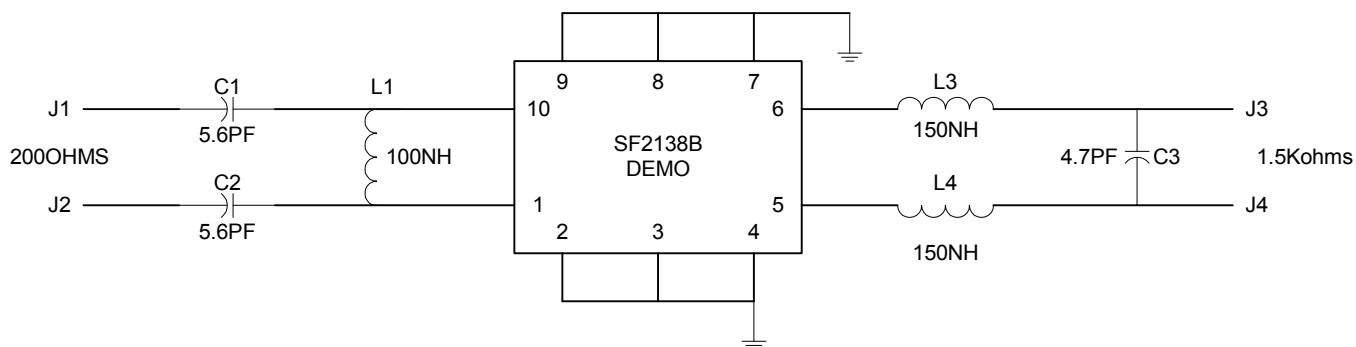

PCB,	400-1749-001		
IND,	501-0782-101	0805 COIL CRAFT, 100NH	L1
IND,	501-0782-151	0805 COIL CRAFT, 150NH	L2, L3
CAP,	501-1275-056	0805, 5.6PF	C1, C2
CAP,	501-1275-047	0805, 4.7PF	C3



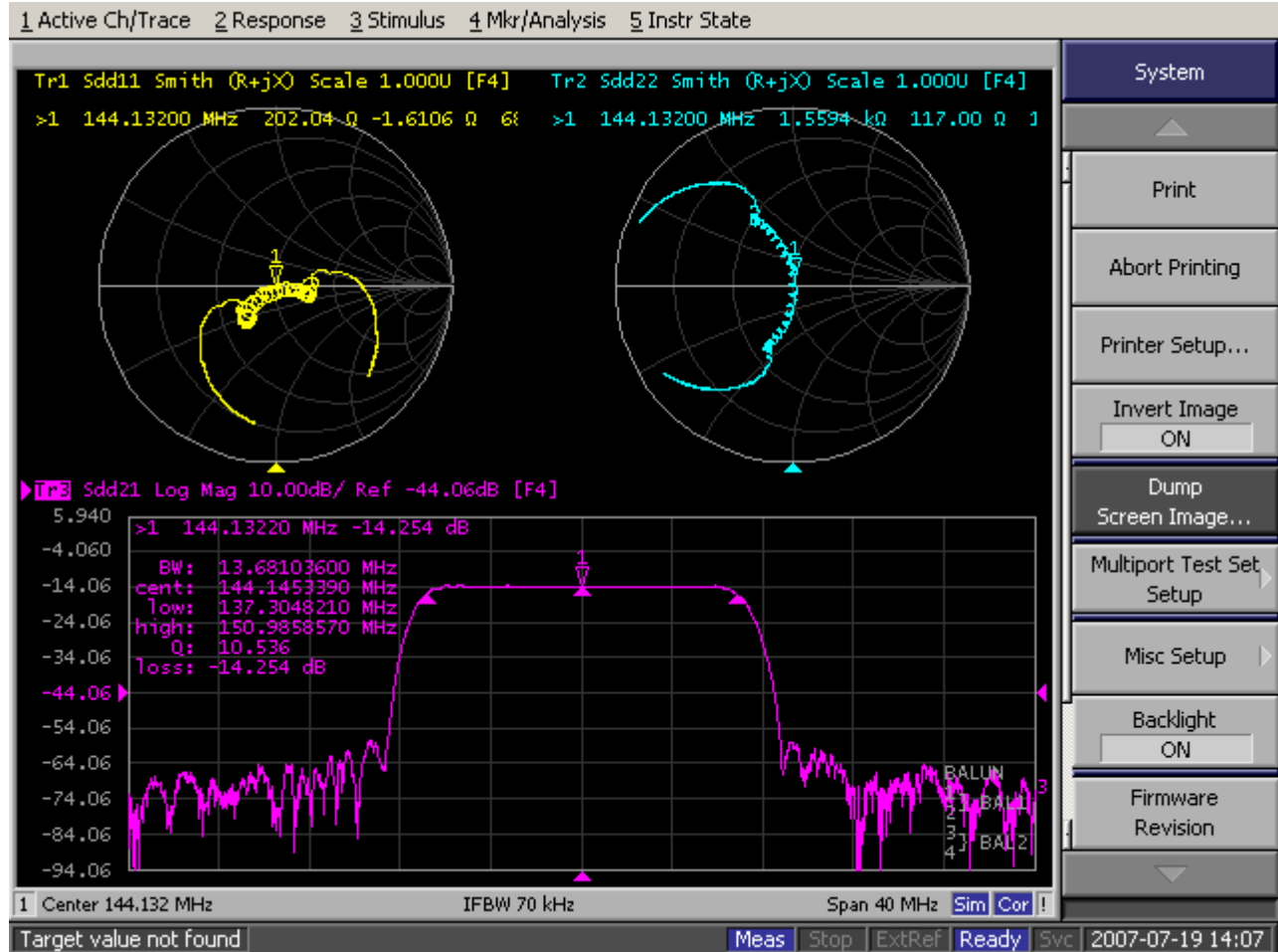

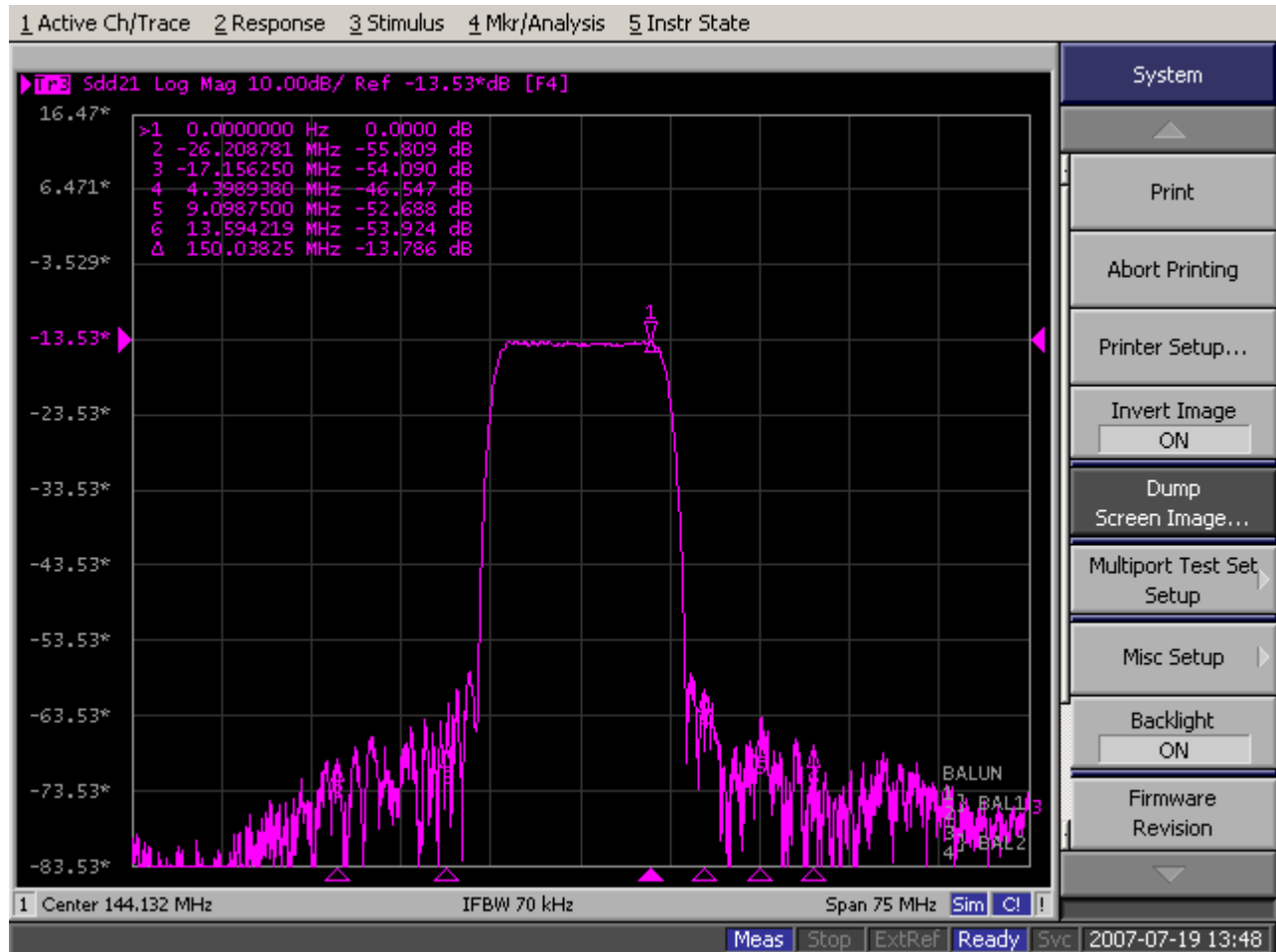

# SMP-03 Case

## 10-Terminal Ceramic Surface-Mount Case 7 x 5 mm Nominal Footprint

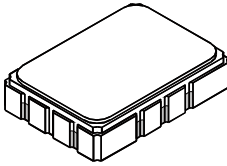

Recommended PCB Footprint

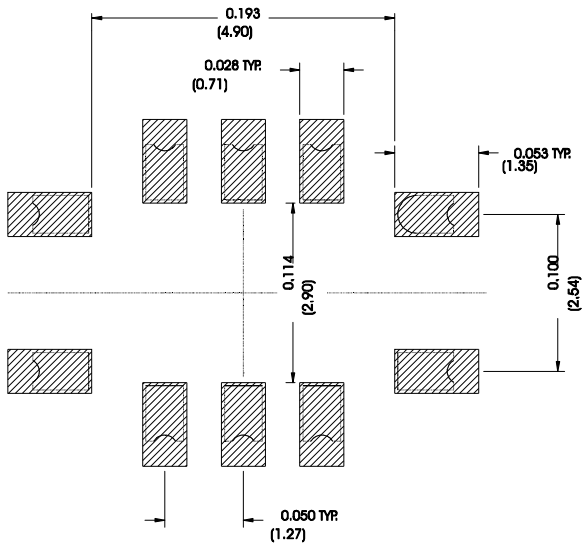

Case Dimensions						
Dimension	mm			Inches		
	Min	Nom	Max	Min	Nom	Max
A	6.80	7.00	7.20	0.268	0.276	0.283
B	4.80	5.00	5.20	0.189	0.197	0.205
C		1.65	2.00		0.065	0.079
D	.47	0.60	.73	0.019	0.024	0.029
E	2.41	2.54	2.67	0.095	0.100	0.105
H	0.87	1.0	1.13	0.034	0.039	0.044
J	4.87	5.00	5.13	0.192	0.197	0.202
K	2.87	3.00	3.13	0.113	0.118	0.123
P	1.14	1.27	1.40	0.045	0.050	0.055

Materials	
Solder Pad Plating	0.3 to 1.0 $\mu\text{m}$ Gold over 1.27 to 8.89 $\mu\text{m}$ Nickel
Lid Plating	2.0 to 3.0 $\mu\text{m}$ Nickel
Body	$\text{Al}_2\text{O}_3$ Ceramic
Pb Free	

Electrical Connections		
Connection		Terminals
Port 1	Input or Return	10
	Return or Input	1
Port 2	Output or Return	5
	Return or Output	6
Ground		All others
Single-ended Operation		Return is ground
Differential Operation		Return is hot

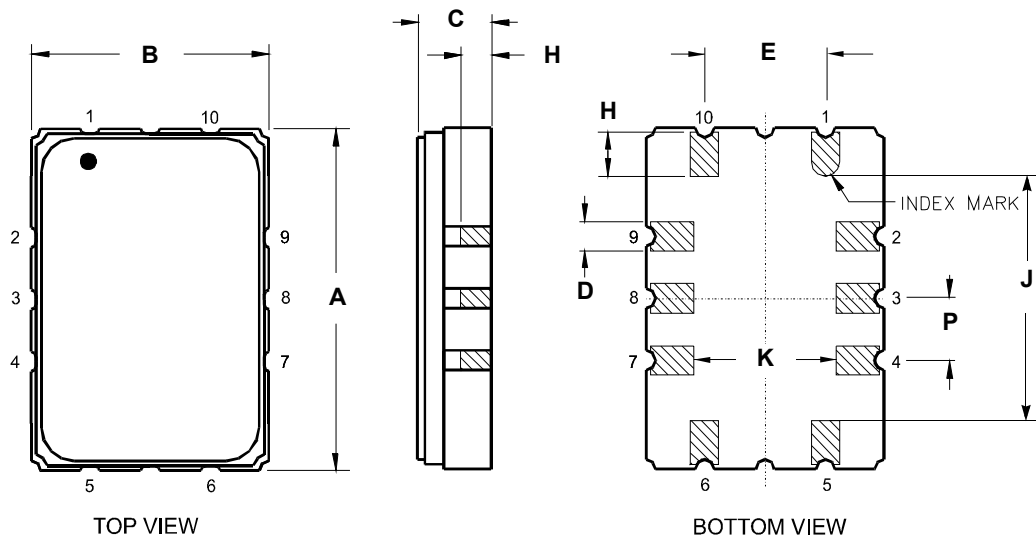

## Tape and Reel Specifications

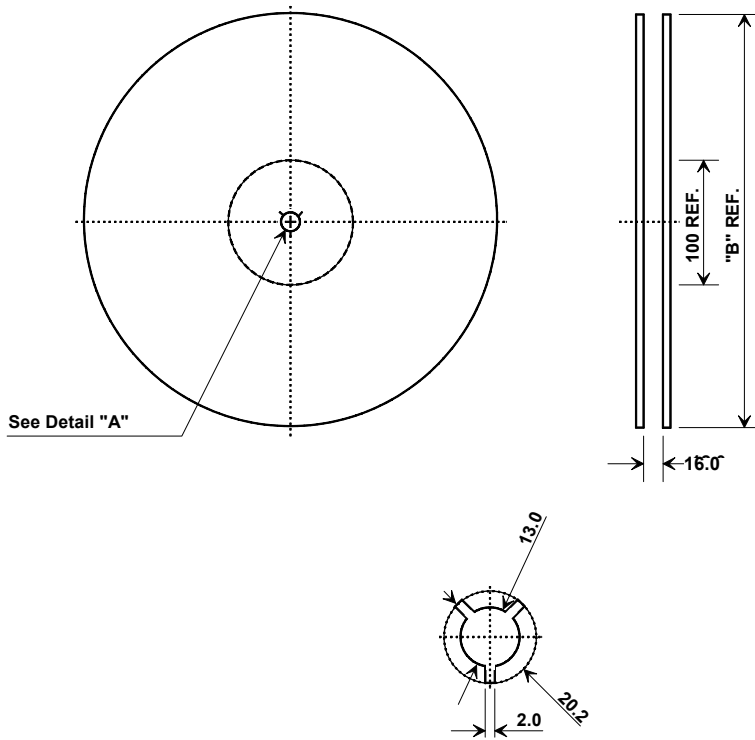

"B"		Quantity Per Reel
Inches	millimeters	
7	178	500
13	330	2000

## COMPONENT ORIENTATION and DIMENSIONS

Carrier Tape Dimensions	
<b>Ao</b>	5.5 mm
<b>Bo</b>	7.5 mm
<b>Ko</b>	2.0 mm
<b>Pitch</b>	8.0 mm
<b>W</b>	16.0 mm

