

# ULTRA MINIATURE OCXO MV118

## Features:

- Small package of 20x20x10 mm
- High stability vs temperature – up to  $\pm 1 \times 10^{-8}$
- Frequency range: 10.0 – 25.0 MHz
- 3.3V or 5V supply voltage
- Available as RoHS
- Output type – HCMOS

Power Supply
5 V
3.3 V

## ORDERING GUIDE: MV118-B 20 - G - 3.3V - 10.0 MHz

Availability of certain stability vs. operating temperature		$\pm 1 \times 10^{-7}$	$\pm 5 \times 10^{-8}$	$\pm 2 \times 10^{-8}$	$\pm 1 \times 10^{-8}$
		100	50	20	10
A	0...+55°C	A	A	A	C
B	- 10...+60°C	A	A	A	C
C	- 20...+70°C	A	A	A	NA
D	- 40...+70°C	A	A	C	NA
EX	- 40...+85°C	A	C	NA	NA

A – available, NA – not available, C – consult factory

For other temperature ranges see designation at the end of Data Sheet

Availability of certain aging values for certain frequencies		Standard frequencies, MHz				
		10,0	12,8	13,0	16,384	20,0
H	$\pm 2.0 \times 10^{-7}$ /year	A	A	A	A	A
G	$\pm 1.0 \times 10^{-7}$ /year	A	A	A	A	C
F	$\pm 5.0 \times 10^{-8}$ /year	A	A	A	C	NA
E	$\pm 3.0 \times 10^{-8}$ /year	A	C	C	NA	NA

A – available, NA – not available, C – consult factory

## Package drawing:

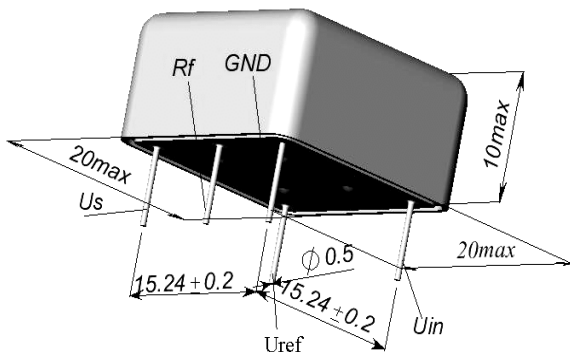

<b>Vibrations:</b>	
Frequency range	10-500 Hz
Acceleration	10g
<b>Shock:</b>	
Acceleration	75 g
Duration	3±1 ms
Storage temperature range	-55...+85 °C

## Additional notes:

- Showed values of frequency stability vs. temperature usually are tested in Still Air test conditions. Please inform factory about different conditions in operation to provide appropriate tests.
- Please consult factory for daily aging values. Normally typical correspondence of daily aging per day to aging per year is as following:  $\pm 2 \times 10^{-7}$ /year -  $\pm 2 \times 10^{-9}$ /day;  $\pm 1 \times 10^{-7}$ /year -  $\pm 1 \times 10^{-9}$ /day;  $\pm 5 \times 10^{-8}$ /year -  $\pm 5 \times 10^{-10}$ /day.
- Please mention RoHS requirement (if any) while requesting for quote or while placing PO.
- For non standard operating temperature ranges please use the following two letters designations (first letter for the lower limit, second letter for the upper limit), °C:

A	B	C	D	E	F	G	H	J	K	L	M	N	P	Q	R	S	T	U	W	X
-60	-55	-50	-45	-40	-30	-20	-10	0	+10	+30	+40	+45	+50	+55	+60	+65	+70	+75	+80	+85

Frequency stability vs. load changes	$< \pm 5 \times 10^{-9}$	
Frequency stability vs. power supply changes	$< \pm 5 \times 10^{-9}$	
Power supply (Us)	5V±5%	3.3V±5%
Current consumption at steady state	< 150 mA	< 250 mA
Peak current consumption during warm-up @ 25°C	< 450 mA	< 700 mA
Warm-up time within $< \pm 1 \times 10^{-7}$ @ 25°C	< 3 min	
Frequency pulling range	$> \pm 5 \times 10^{-7}$	
with external voltage range (Uin)	0...+4.5 V	0...+3.0 V
or with external potentiometer	20 kOhm	
reference voltage output (Uref)	+ 4.5 V	+3.0 V
Pulling slope	Positive	
Output	HCMOS	
Load	10 kOhm/15 pF	
Level High/Low	4.5/0.5V	3.0/0.3V

Phase noise, dB/Hz, at	10 - 13 MHz	> 13 - 25 MHz
	1 Hz	< -90
	10 Hz	< -120
	100 Hz	< -140
	1000 Hz	< -145
	10000 Hz	< -150
Short term stability (Allan deviation) per 1 sec, typical	$< 1 \times 10^{-11}$	$< 2 \times 10^{-11}$