

Preliminary

RFM products are now
Murata products.

SF1186G-2

**1575.42 MHz
SAW Filter**

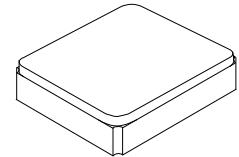

SM2520-5

- *Designed for Front-end GPS Applications*
- *Steep Rejection*
- *Single-ended Input/Balanced Output*
- *2.5 x 2.0 x 1.0 mm Surface-mount Case*
- *Complies with Directive 2002/95/EC (RoHS)*



Absolute Maximum Ratings

Rating	Value	Units
Maximum Input Power	+10	dBm
Maximum DC Voltage On any Non-ground Terminal	3	VDC
Storage Temperature Range in Tape and Reel	-40 to +85	°C
Maximum Soldering Profile (5 cycles maximum)	265 °C for 10 s	

Electrical Characteristics

Characteristic	Sym	Notes	Min	Typ	Max	Units
Nominal Center Frequency	f_C			1575.42		MHz
Passband Insertion Loss, 1574.42 to 1576.42 MHz	IL			1.35	1.90	dB
Amplitude Ripple, 1574.42 to 1576.42 MHz				0.1	0.5	dB _{p,p}
VSWR, 1574.42 to 1576.42 MHz				1.3	1.8	
Output Amplitude Balance, 1574.42 to 1576.42 MHz, $ S_{31}/S_{21} $			-2.0	1.3	2.0	dB
Output Phase Balance, 1574.42 to 1576.42 MHz			-10	1	+10	deg
Attenuation Referenced to 0 dB:						
100 to 960 MHz			40	48		dB
960 to 1425 MHz			35	46		
1425 to 1475 MHz			30	54		
1475 to 1515 MHz			20	39		
1515 to 1525 MHz			17	39		
1625 to 1635 MHz			12	22		
1635 to 1675 MHz			20	24.5		
1675 to 1750 MHz			30	34.5		
1750 to 1805 MHz			35	43.5		
1805 to 1980 MHz			40	50		
1980 to 2400 MHz			35	40		
2400 to 3155 MHz			40	56		
3155 to 6000 MHz			35	55		
Single-ended Source impedance	Z_S			50		Ω
Balanced Load impedance	Z_L			100		Ω
Operating Temperature	T_A		-40		+85	°C
Case Style			SM2520-5			
Lid Symbolization (3T=SF1186G-2 Y=year, W=week)			3T, YW			

Electrical Connections

Connection	Terminals
Input	1
Output	3, 4
Ground	2, 5



CAUTION: Electrostatic Sensitive Device. Observe precautions for handling.

NOTES:

1. US and international patents may apply.
2. Murata, stylized Murata logo, and Murata N.A., Inc. are registered trademarks of Murata Manufacturing Co., Ltd.

Filter Frequency Response Plots

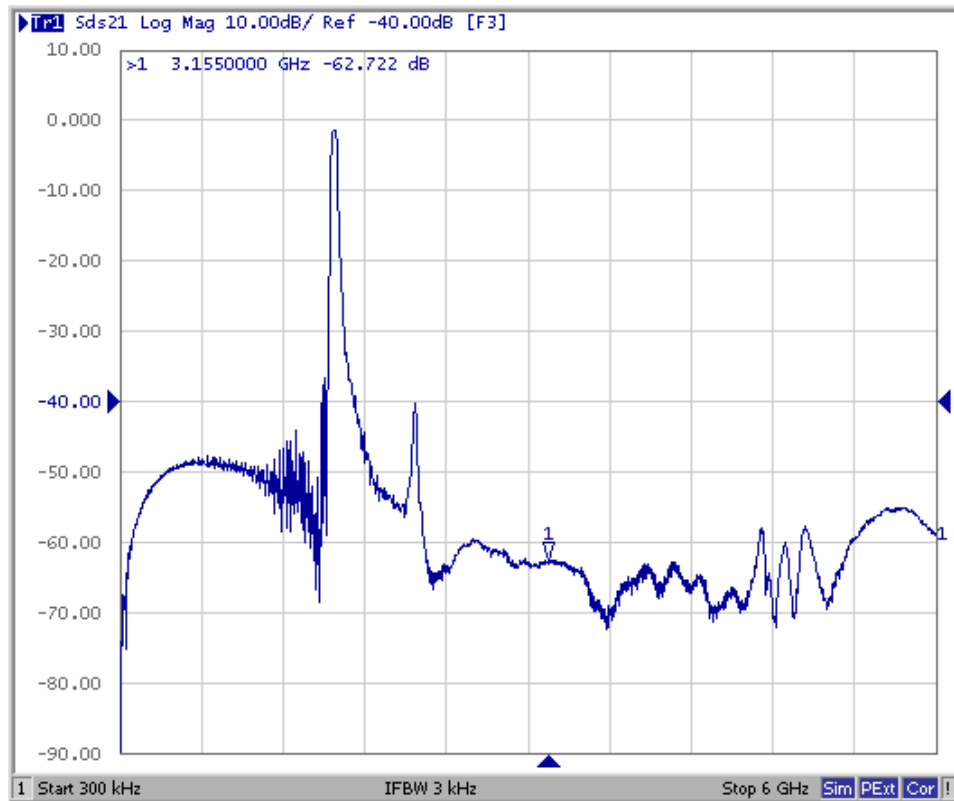
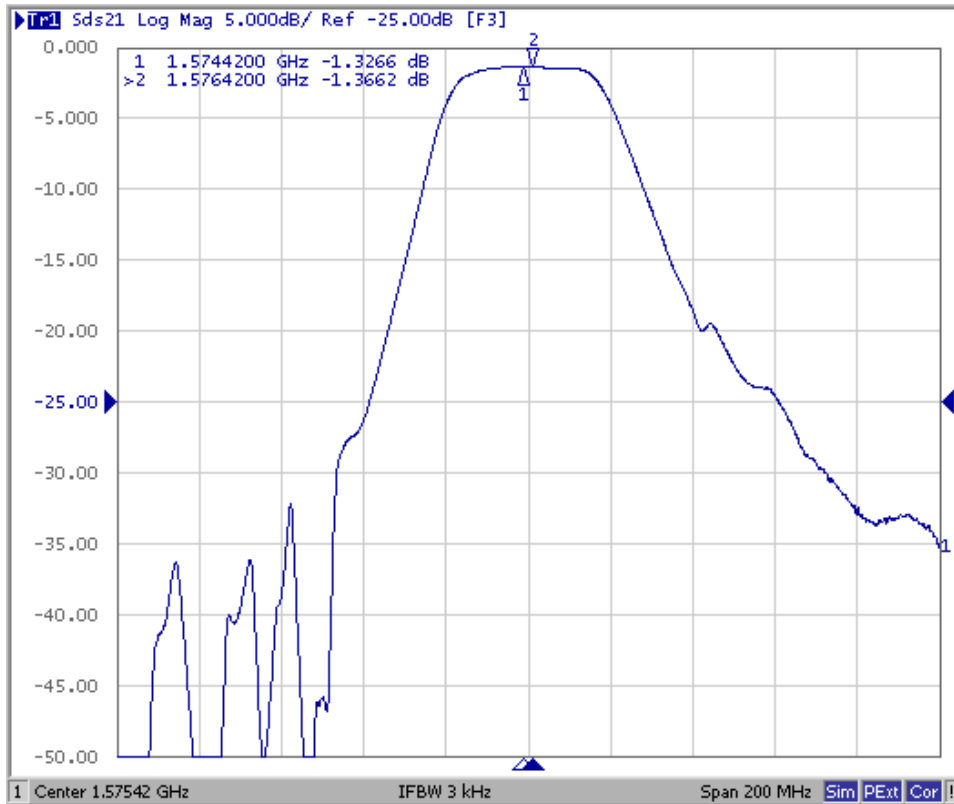

Filter Input/Output VSWR and Impedance Plots

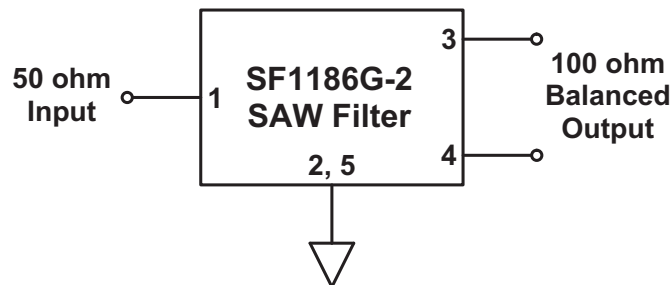
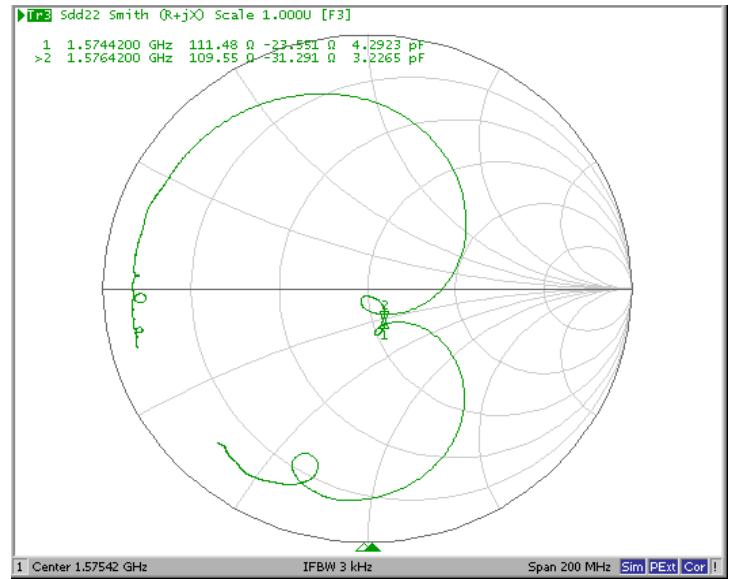
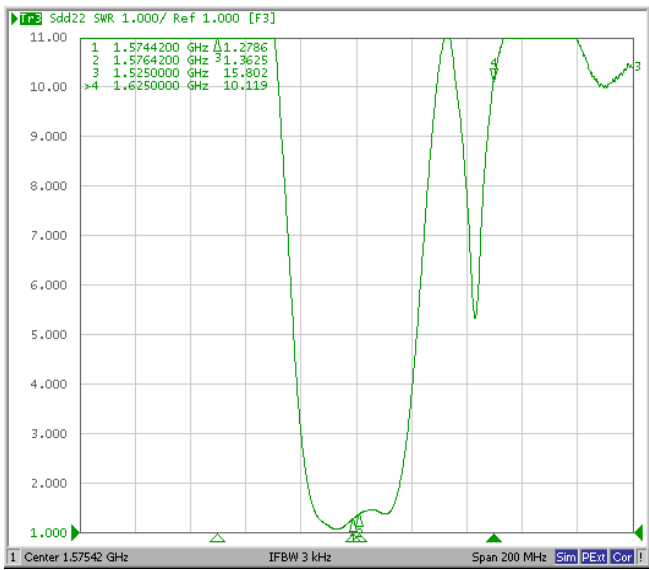
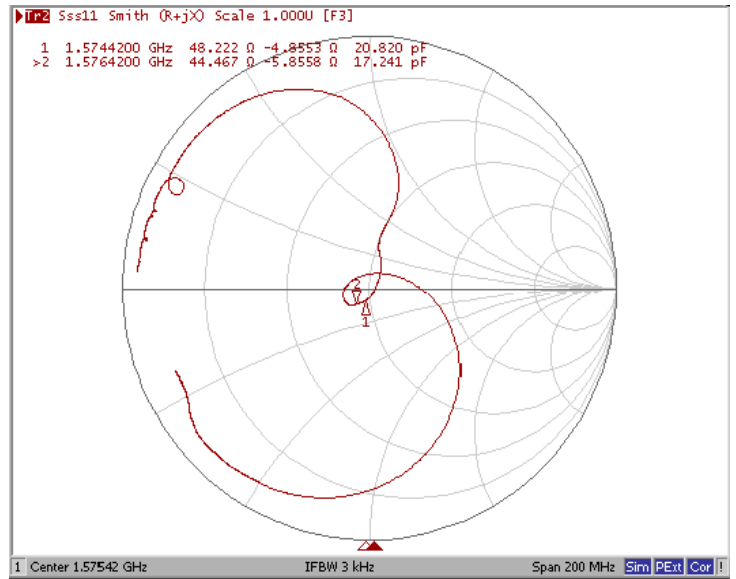
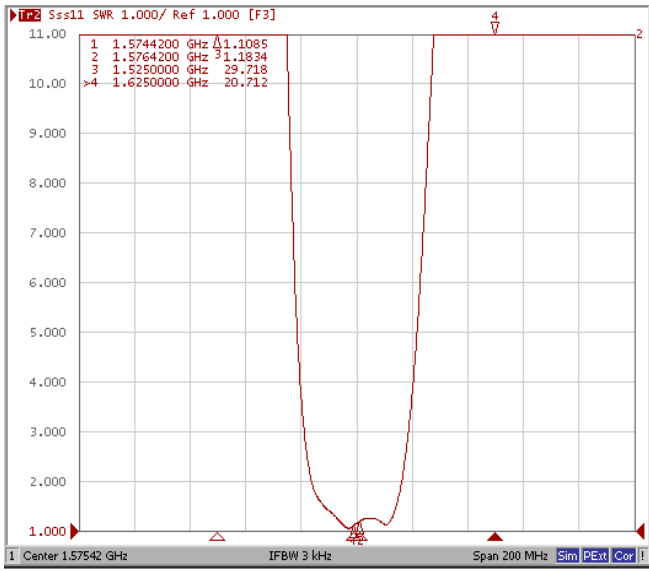

SM2520-5 Case

5-Terminal Ceramic Surface-mount Case 2.5 X 2.0 mm Nominal Footprint

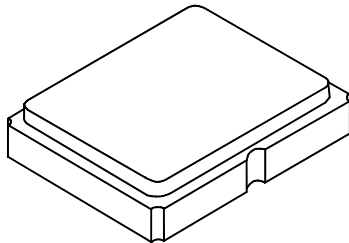

PCB Footprint

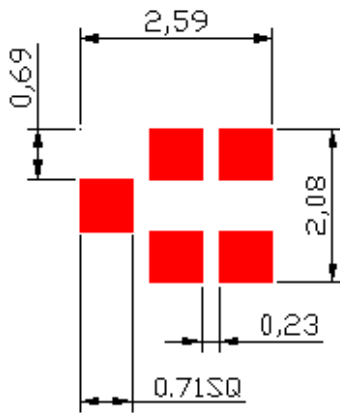

TOP VIEW

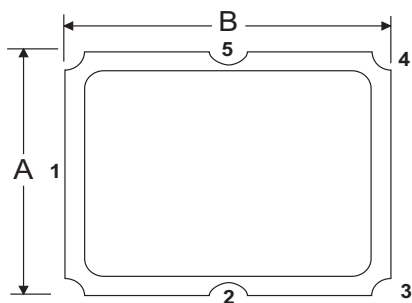

BOTTOM VIEW

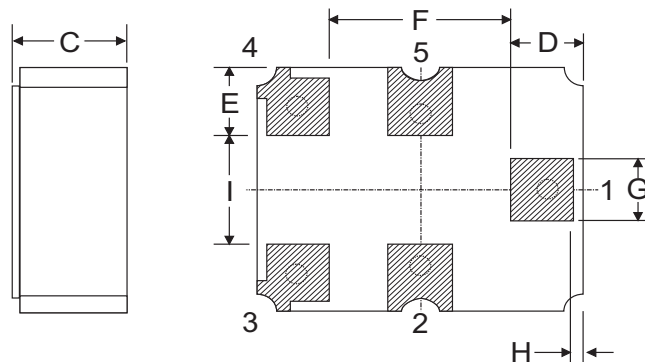

Case Dimensions

Dimension	mm			Inches		
	Nom			Nom		
A	1.88	2.00	2.12	0.074	0.079	0.083
B	2.38	2.50	2.62	0.094	0.098	0.103
C	0.92	1.00	1.08	0.036	0.039	0.043
D		0.55			0.022	
E		0.55			0.022	
F		1.40			0.055	
G		0.50			0.020	
H		0.08			0.003	
I		0.90			0.035	

Case Material

Materials	
Solder Pad Plating	0.3 to 1.0 μm Gold over 1.27 to 8.89 μm Nickel
Lid Plating	2.0 to 3.0 μm Nickel
Body	Al_2O_3 Ceramic
Pb Free	

Reel Dimension

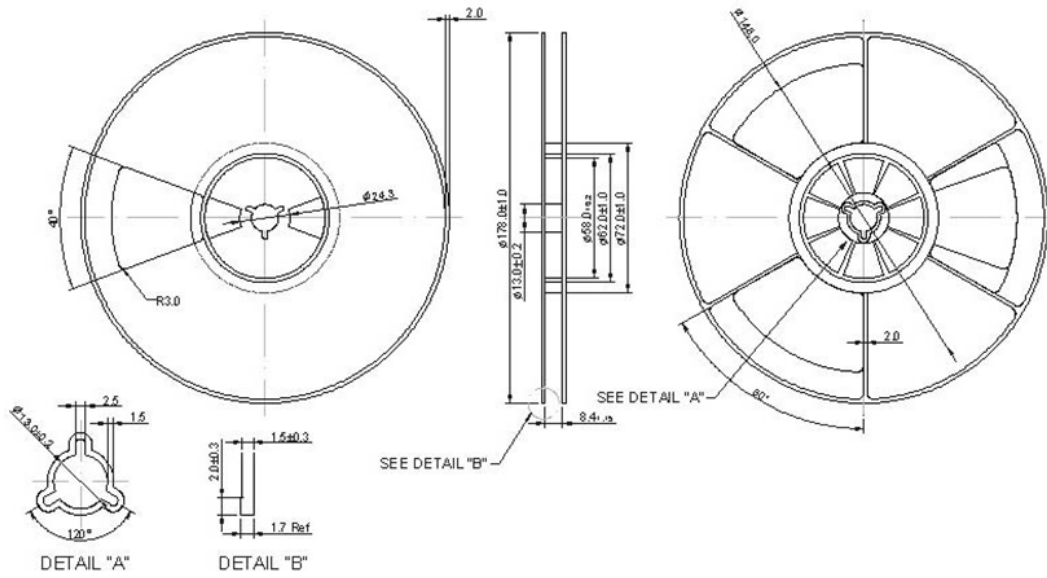

Tape Dimension

