



Package: QFN 16 pin, 3mm x 3mm x 0.5mm



**Features**

- SP3T Switch
- Switch Control Voltage 2.5Vto 5V
- Low Insertion Loss 0.8dB

**Applications**

- IEEE802.11b/g/n WiFi Applications
- WiFi/Bluetooth® Combination Devices

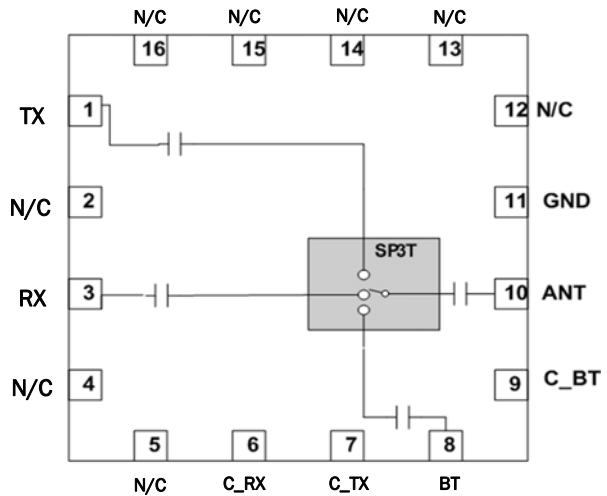

Functional Block Diagram

**Product Description**

The RFSW8005 is a single-pole triple-throw (SP3T) pHEMT switch in a 3mm x 3mm x 0.5mm Pb-free, 16-pin package. This switch is capable of switching between WiFi Rx, WiFi Tx, and Bluetooth Rx/Tx operations. The RFSW8005 can also be placed in WiFi and Bluetooth modes simultaneously with a slight increase in insertion loss. This device meets or exceeds the RF switch needs of IEEE802.11b/g WiFi RF systems.

**Ordering Information**

RFSW8005SQ	25-Piece bag
RFSW8005SR	100-Piece reel
RFSW8005TR7	2500-Piece reel
RFSW8005PCBK-410	RFSW8000 eval board (100MHz to 2000MHz) and 5-piece bag

**Optimum Technology Matching® Applied**

- |                                      |                                      |  |                                    |
|--------------------------------------|--------------------------------------|--|------------------------------------|
| <input type="checkbox"/> GaAs HBT    | <input type="checkbox"/> SiGe BiCMOS | <input checked="" type="checkbox"/> GaAs pHEMT | <input type="checkbox"/> GaN HEMT  |
| <input type="checkbox"/> GaAs MESFET | <input type="checkbox"/> Si BiCMOS   | <input type="checkbox"/> Si CMOS               | <input type="checkbox"/> BIFET HBT |
| <input type="checkbox"/> InGaP HBT   | <input type="checkbox"/> SiGe HBT    | <input type="checkbox"/> Si BJT                | <input type="checkbox"/> SOI       |

RF MICRO DEVICES®, RFMD®, Optimum Technology Matching®, Enabling Wireless Connectivity®, PowerStar®, POLARIS™ TOTAL RADIO™ and UltimateBlue™ are trademarks of RFMD, LLC. BLUETOOTH is a trademark owned by Bluetooth SIG, Inc., U.S.A. and licensed for use by RFMD. All other trade names, trademarks and registered trademarks are the property of their respective owners. ©2012, RF Micro Devices, Inc.

## Absolute Maximum Ratings

Parameter	Rating	Unit
Supply Voltage	6	V
Ruggedness Output VSWR	10:1	
Stability Output VSWR	5:1	
ESD Human Body Model	250	V
ESD Device Model	1000	V
Operating Case Temperature	-40 to +85	°C
Storage Temperature	-40 to +150	°C
Moisture Sensitivity Level	MSL2	

\*Note: Maximum input power with a 50Ω load.



**Caution!** ESD sensitive device.

Exceeding any one or a combination of the Absolute Maximum Rating conditions may cause permanent damage to the device. Extended application of Absolute Maximum Rating conditions to the device may reduce device reliability. Specified typical performance or functional operation of the device under Absolute Maximum Rating conditions is not implied.

The information in this publication is believed to be accurate and reliable. However, no responsibility is assumed by RF Micro Devices, Inc. ("RFMD") for its use, nor for any infringement of patents, or other rights of third parties, resulting from its use. No license is granted by implication or otherwise under any patent or patent rights of RFMD. RFMD reserves the right to change component circuitry, recommended application circuitry and specifications at any time without prior notice.



RFMD Green: RoHS compliant per EU Directive 2011/65/EU, halogen free per IEC 61249-2-21, < 1000 ppm each of antimony trioxide in polymeric materials and red phosphorus as a flame retardant, and <2% antimony in solder.

Parameter	Specification			Unit	Condition
	Min.	Typ.	Max.		
<b>Operating Parameters</b>					
Frequency	2.4		2.5	GHz	
Switch Control Voltage: Low	0		0.20	V	
Switch Control Voltage: High	2.5		5.0	V	
Operating Temperature	-40		85	°C	
<b>TX - ANT</b>					
Insertion Loss		0.8	1.2	dB	CW Signal, C_TX = 2.5V to 5.0V; T = -40 °C to 85 °C; Unless otherwise noted.
		0.8		dB	C_TX = 2.8V; T = 25 °C
Input Return Loss		15	10	dB	
Output Return Loss		15	8	dB	
Isolation					
TX - RX	20			dB	Measured from ANT - RX in TX mode
TX - BT	23			dB	Measured from ANT - BT in TX mode
<b>RX - ANT</b>					
Insertion Loss		0.9	1.5	dB	CW Signal, C_RX = 2.5V to 5.0V; T = -40 °C to 85 °C; Unless otherwise noted.
		0.9		dB	C_RX = 2.5V to 5.0V; T = 25 °C
Input Return Loss		14	11	dB	
Output Return Loss		14	11	dB	
Isolation					
RX - TX	17			dB	Measured from ANT - TX in RX mode
RX - ANT	22			dB	Measured from ANT - BT in RX mode

Parameter	Specification			Unit	Condition
	Min.	Typ.	Max.		
<b>Operating Parameters (continued)</b>					
<b>BT - ANT</b>					CW Signal, C_BT = 2.5V to 5.0V; T = -40 °C to 85 °C; Unless otherwise noted.
BT Insertion Loss		0.8	1.3	dB	
		0.8		dB	C_BT = 2.5V to 5.0V; T = 25 °C
Input Return Loss		12	8	dB	
Isolation					
BT - TX	18			dB	Measured from ANT - TX in BT mode
BT - RX	19			dB	Measured from ANT - RX in BT mode
<b>General Parameters</b>					All Modes = C_TX or C_RX or C_BT; T=-40 °C to 85 °C; Unless otherwise noted.
Passband Ripple	-0.3		+0.3	dB	All Modes
IPO.1dB; CW	20			dBm	All Modes; Switch Control = 2.5V; CW
	20			dBm	All Modes; Switch Control = 2.8V; CW
	24			dBm	All Modes; Switch Control = 3.1V; CW
	30			dBm	All Modes; Switch Control = 5.0V; CW
Switch Control Current; High			3	μA	All Modes; Switch Control = 2.5V; T = 25 °C
			5	μA	All Modes; Switch Control ≤ 3.1V
			10	μA	All Modes; Switch Control = 5.0V
Switch Time, 10% CTL to 90% RF		200	800	ns	All Modes; Switch Control = 2.5V to 5.0V
Switch Time, 90% CTL to 10% RF		200	800	ns	

### Switch Control Logic

Mode	C_TX	C_BT	C_RX	Condition
TX	1	0	0	TX to ANT
BT	0	1	0	BT to ANT
RX	0	0	1	RX to ANT
BT/RX	0	1	1	BT TX/RX Coexistence

## Pin Names and Description

Pin	Name	Description
1	TX	TX RF port.
2	N/C	Not connected.
3	GND	Ground.
4	N/C	Not connected.
5	N/C	Not connected.
6	C_RX	Switch control to enable RX to ANT.
7	C_TX	Switch control to enable TX to ANT.
8	BT	BT RF port.
9	C_BT	Switch control to enable BT to ANT.
10	ANT	ANT RF port.
11	GND	Ground.
12	N/C	Not connected.
13	N/C	Not connected.
14	N/C	Not connected.
15	N/C	Not connected.
16	N/C	Not connected.

## Pin Out

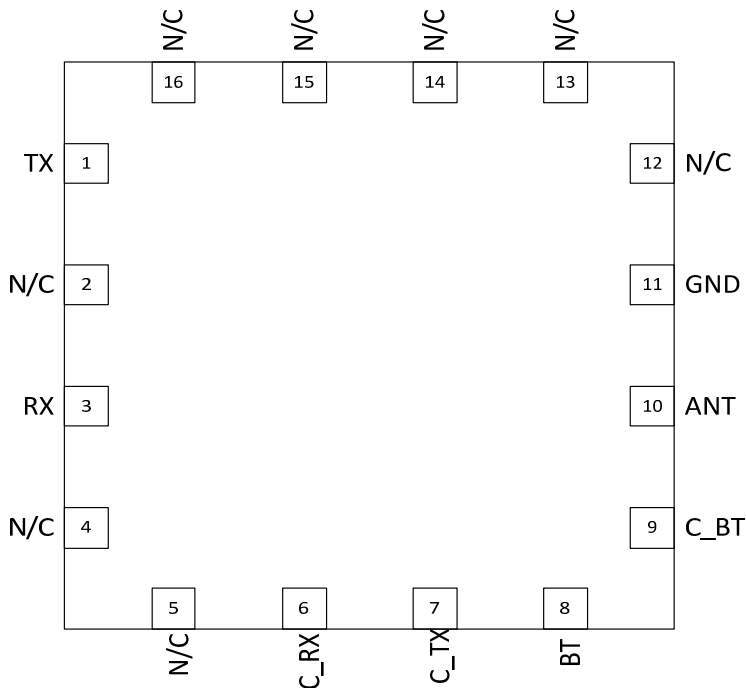

**Package Drawing**

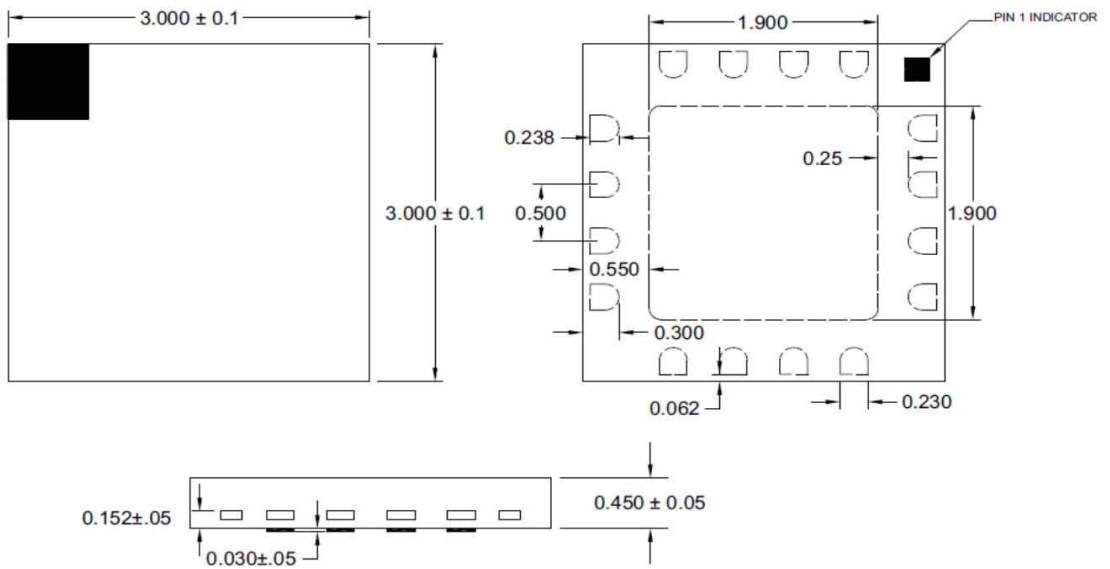

**NOTES:**

- 1 Shaded Area is Pin 1 Indicator

## Application Schematic

