

## Features

- 16.8 dB Gain at 2 GHz
- 22 dBm P1dB at 2 GHz
- 31 dBm Output IP3 at 2 GHz
- 1.8 dB NF at 2 GHz
- MTTF > 100 Years
- Single Supply

## Description

The ASW234, a power amplifier MMIC, has a high linearity, high gain, and high efficiency over a wide range of frequency, being suitable for use in both receiver and transmitter of telecommunication systems up to 6 GHz. The amplifier is available in a SOT363 package and passes through the stringent DC, RF, and reliability tests.

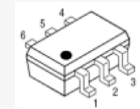

Package Style: SOT363

## Typical Performance

(Supply Voltage = +5 V, T<sub>A</sub> = +25 °C, Z<sub>0</sub> = 50 Ω)

Parameters	Units	Typical				
Frequency	MHz	900	2000	2700	3500	5500
Gain	dB	18.7	16.8	15.5	13.5	10.0
S11	dB	-10	-11	-15	-15	-12
S22	dB	-18	-18	-15	-12	-10
Output IP3 <sup>1)</sup>	dBm	29.5	31.0	31.5	31.0	28.0
Noise Figure	dB	1.9	1.8	1.9	2.2	3.3
Output P1dB	dBm	22.0	22.0	20.5	18.5	14.5
Current	mA	55	55	55	55	55
Device Voltage	V	+5	+5	+5	+5	+5

1) OIP3 is measured with two tones at an output power of +5 dBm/tone separated by 1 MHz.

## Product Specifications

Parameters	Units	Min	Typ.	Max
Testing Frequency	MHz		2000	
Gain	dB		16.8	
S11	dB		-11	
S22	dB		-18	
Output IP3	dBm		31	
Noise Figure	dB		1.8	
Output P1dB	dBm		22	
Current	mA		55	
Device Voltage	V		+5	

## Absolute Maximum Ratings

Parameters	Rating
Operating Case Temperature	-40 to +85 °C
Storage Temperature	-40 to +150 °C
Device Voltage	+5 V
Operating Junction Temperature	+150 °C
Input RF Power (Continuous)	19 dBm

\* Please find the max. input power data from [http://www.asb.co.kr/pdf/Maximum\\_Input\\_Power\\_Analysis.pdf](http://www.asb.co.kr/pdf/Maximum_Input_Power_Analysis.pdf)

## Application Circuit

- 500 ~ 3500 MHz
- 500 ~ 3500 MHz (4.7 V)
- 500 ~ 3500 MHz (3 V)
- IF
- DVB-T (V & U band)
- 5000 ~ 6000 MHz

## Pin Configuration

Pin No.	Function
1	RF OUT & Bias
2,3,5,6	GND
4	RF IN

### Outline Drawing

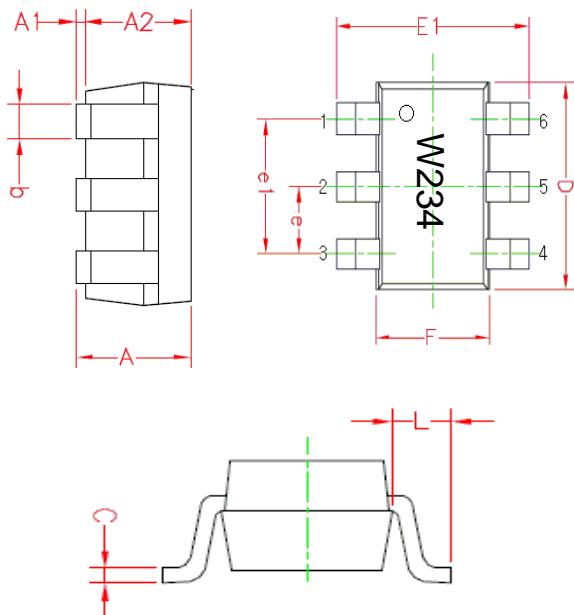

Symbols	Dimensions (In mm)		
	MIN	NOM	MAX
A	0.900	1.000	1.10
A1	0.025	0.062	0.10
A2	0.875	0.937	1.00
b	0.200	0.300	0.40
C	0.100	0.125	0.15
D	1.900	2.000	2.10
F	1.150	1.250	1.35
E1	2.000	2.100	2.20
e	--	0.65BSC	--
e1	--	1.30BSC	--
L	--	0.425REF	--

Pin NO.	Function	Pin NO.	Function.
1	RF OUT & Bias	4	RF IN
2	GND	5	GND
3	GND	6	GND

### Mounting Recommendation (In mm)

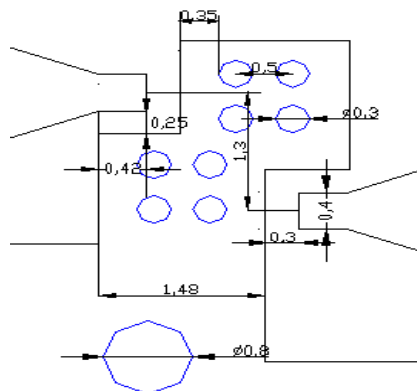

- Note:**
1. The number and size of ground via holes in a circuit board is critical for thermal and RF grounding considerations.
  2. We recommend that the ground via holes be placed on the bottom of lead pin 2 for better RF and thermal performance, as shown in the drawing at the left side.

### ESD Classification & Moisture Sensitivity Level

#### ESD Classification

HBM	Class 1A
	Voltage Level: 400 V
MM	Class A
	Voltage Level: 50 V

CAUTION: ESD-sensitive device!

#### Moisture Sensitivity Level (MSL)

Level 3 at 260 °C reflow

### APPLICATION CIRCUIT

Wide Band

500 ~ 3500 MHz

+5 V

Frequency (MHz)	900	2000	2700	3500
Magnitude S21 (dB)	18.7	16.8	15.5	13.5
Magnitude S11 (dB)	-10	-11	-15	-15
Magnitude S22 (dB)	-18	-18	-15	-12
Output P1dB (dBm)	22.0	22.0	20.5	18.5
Output IP3 <sup>1)</sup> (dBm)	29.5	31.0	31.5	31.0
Noise Figure (dB)	1.9	1.8	1.9	2.2
Device Voltage (V)	+5	+5	+5	+5
Current (mA)	55	55	55	55

1) OIP3 is measured with two tones at an output power of +5 dBm/tone separated by 1MHz.

### Schematic

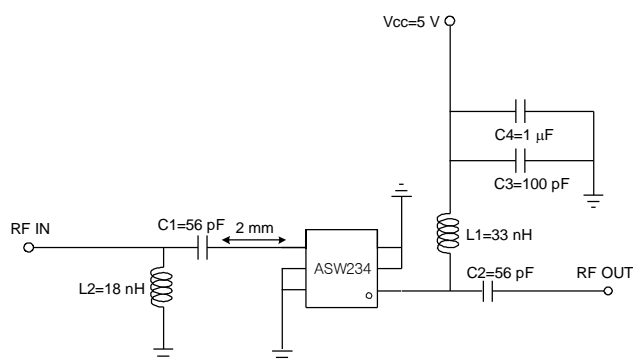

### Board Layout (FR4, 40x40 mm<sup>2</sup>, 0.8T)

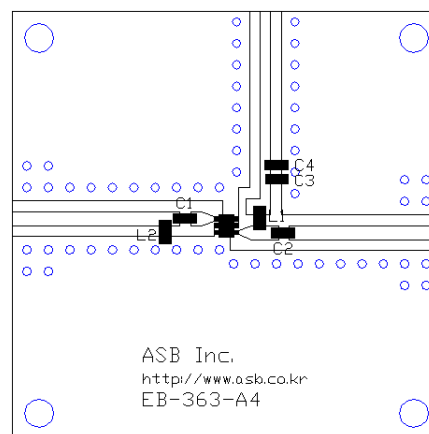

### S-parameters & K-factor

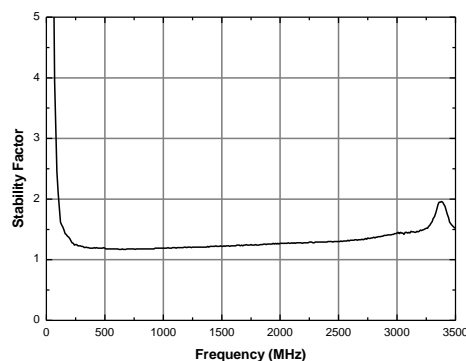
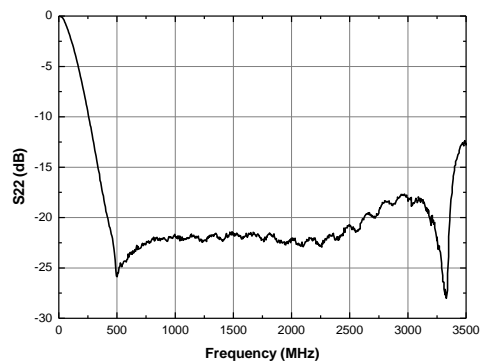
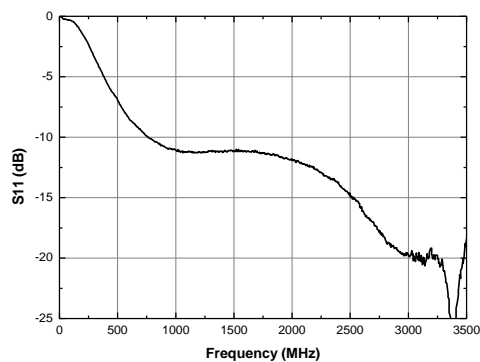
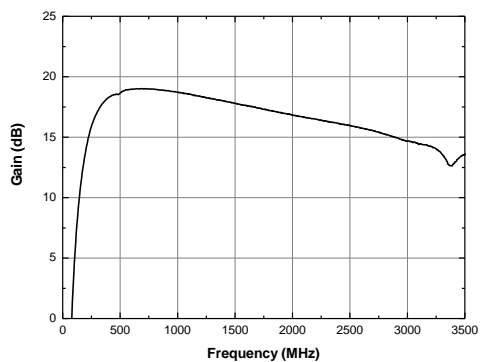

### APPLICATION CIRCUIT

Wide Band  
500 ~ 3500 MHz  
+4.7 V

Frequency (MHz)	900	2000	2700	3500
Magnitude S21 (dB)	17.8	16.2	15.0	13.5
Magnitude S11 (dB)	-9	-12	-18	-12
Magnitude S22 (dB)	-15	-18	-14	-12
Output P1dB (dBm)	21.0	21.0	19.5	19.5
Output IP3 <sup>1)</sup> (dBm)	26	29	30	31
Noise Figure (dB)	1.8	1.8	1.9	2.2
Device Voltage (V)	4.7	4.7	4.7	4.7
Current (mA)	35	35	35	35

1) OIP3 is measured with two tones at an output power of +5 dBm/tone separated by 1MHz.

### Schematic

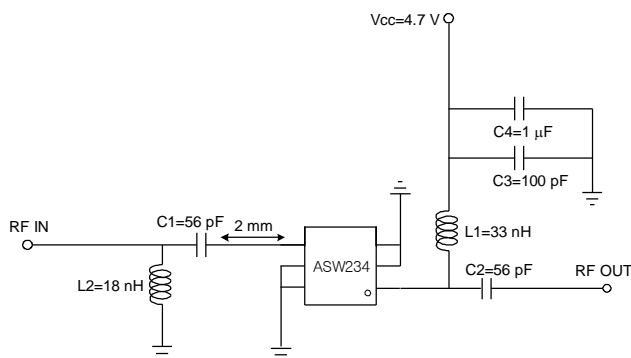

### Board Layout (FR4, 40x40 mm<sup>2</sup>, 0.8T)

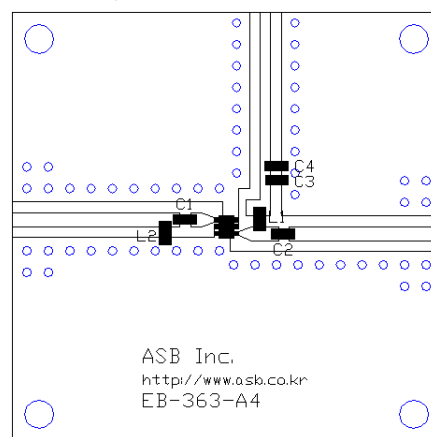

### S-parameters & K-factor

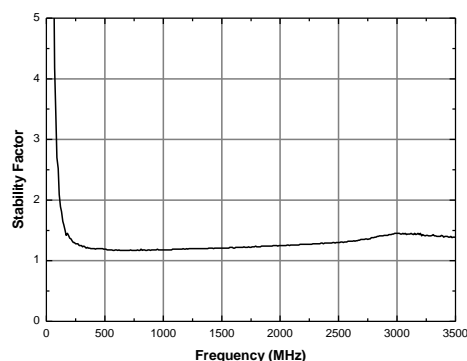
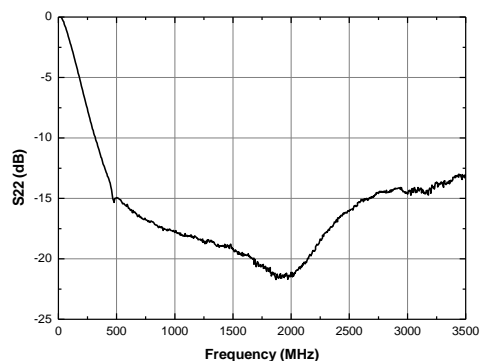
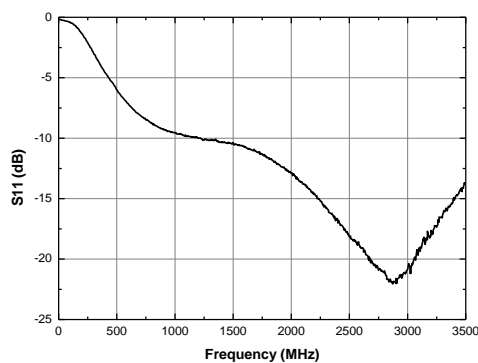
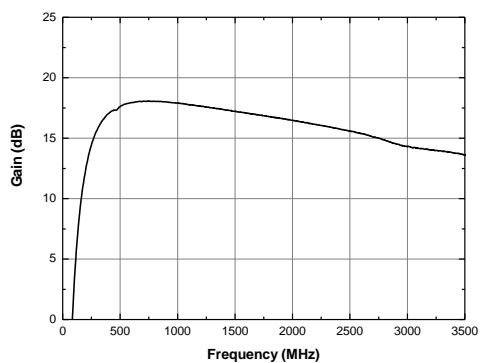

### APPLICATION CIRCUIT

**Wide Band**  
**500 ~ 3500 MHz**  
**+3 V**

Frequency (MHz)	900	2000	2700	3500
Magnitude S21 (dB)	18.8	16.5	14.8	12.5
Magnitude S11 (dB)	-11	-14	-18	-13
Magnitude S22 (dB)	-18	-16	-14	-18
Output P1dB (dBm)	16.5	17.0	15.5	16.5
Output IP3 <sup>1)</sup> (dBm)	31	32	34	31
Noise Figure (dB)	2.2	2.2	2.4	2.6
Device Voltage (V)	+3	+3	+3	+3
Current (mA)	53	53	53	53

1) OIP3 is measured with two tones at an output power of +5 dBm/tone separated by 1MHz.

### Schematic

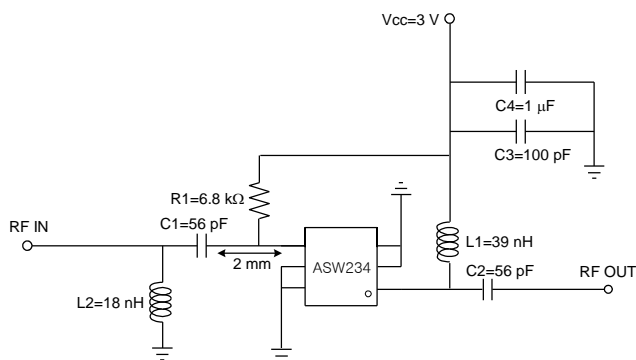

### Board Layout (FR4, 40x40 mm<sup>2</sup>, 0.8T)

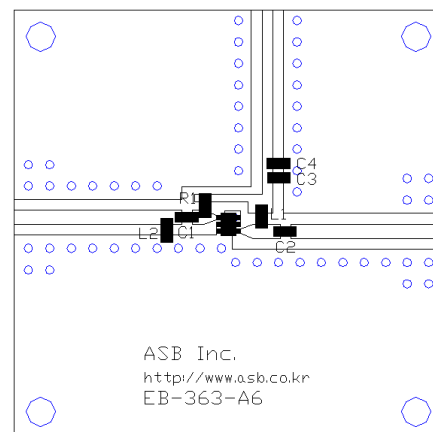

### S-parameters & K-factor

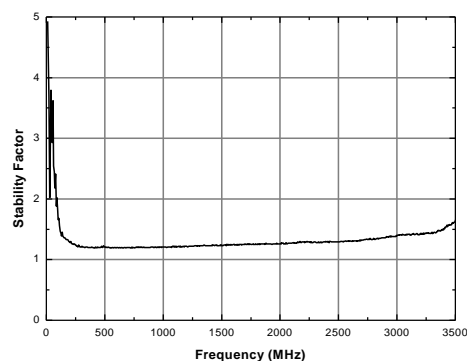
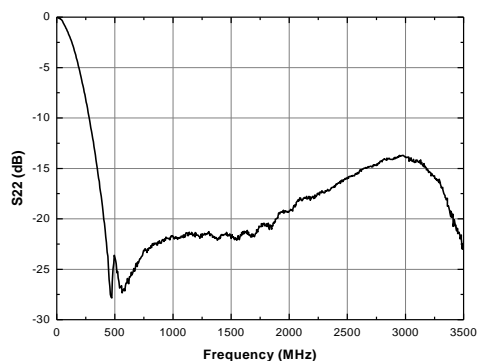
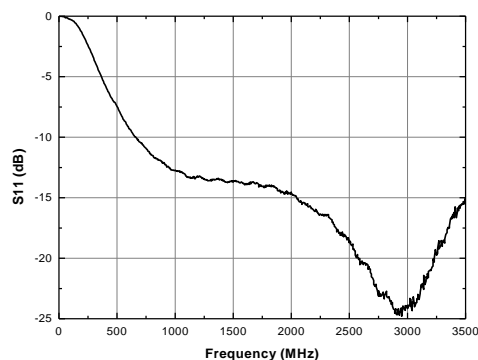
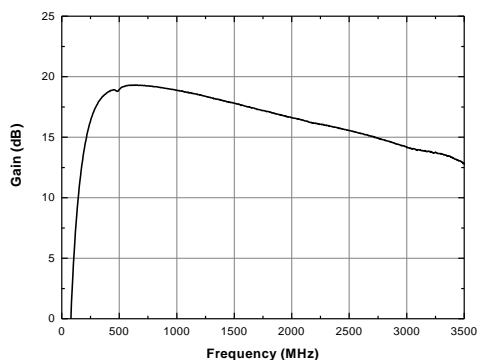

### APPLICATION CIRCUIT

\_\_\_\_\_  
**IF**  
 \_\_\_\_\_  
**50 ~ 450 MHz**  
 \_\_\_\_\_  
**+5 V**  
 \_\_\_\_\_

Frequency (MHz)	70	150	300
Magnitude S21 (dB)	21.0	20.0	19.5
Magnitude S11 (dB)	-5	-8	-9
Magnitude S22 (dB)	-13	-16	-18
Output P1dB (dBm)	21.5	21.5	21.5
Output IP3 <sup>1)</sup> (dBm)	27	28	29
Noise Figure (dB)	2.8	2.2	2.1
Device Voltage (V)	+5	+5	+5
Current (mA)	55	55	55

1) OIP3 is measured with two tones at an output power of +5 dBm/tone separated by 1MHz.

### Schematic

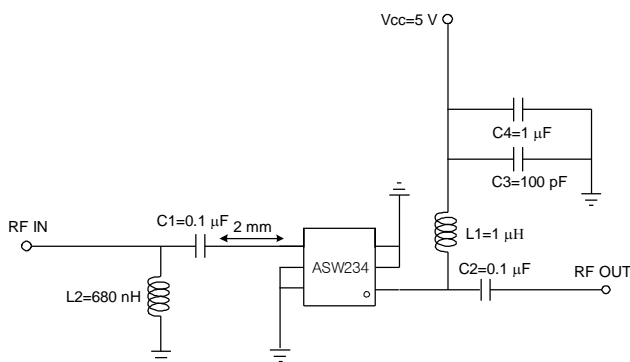

### Board Layout (FR4, 40x40 mm<sup>2</sup>, 0.8T)

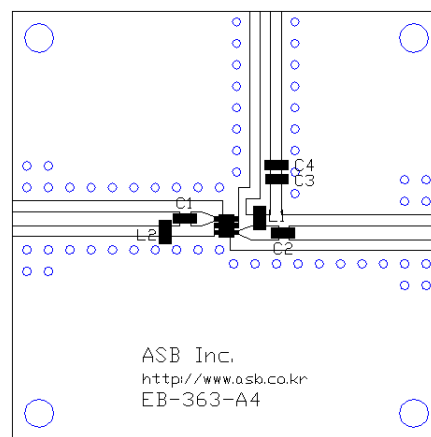

### S-parameters & K-factor

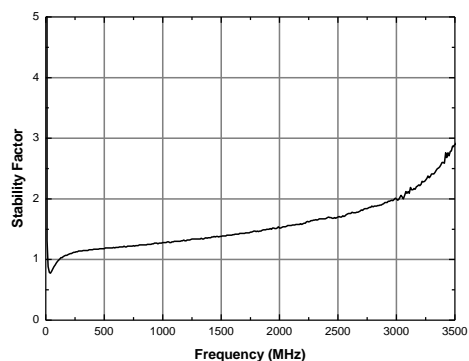
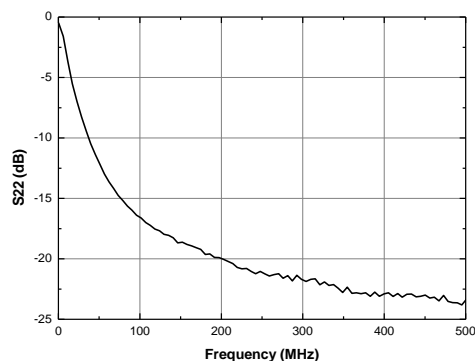
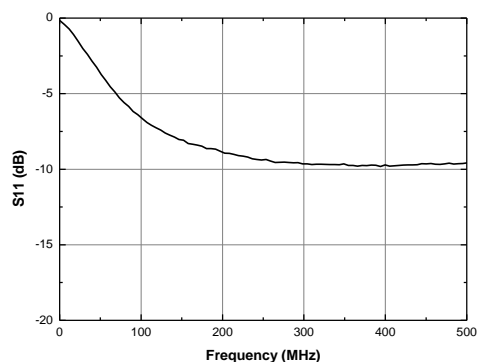
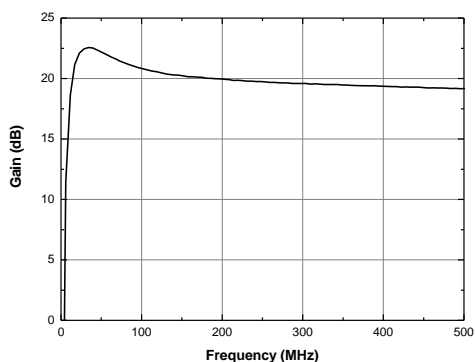

### APPLICATION CIRCUIT

DVB-T ( V & U band)

170 ~ 860 MHz

+4.5 V

Frequency (MHz)	170	860
Magnitude S21 (dB)	18	16
Magnitude S11 (dB)	-5	-7
Magnitude S22 (dB)	-13	-15
Output P1dB (dBm)	20	20
Output IP3 <sup>1)</sup> (dBm)	23.5	23.5
Noise Figure (dB)	1.7	2.1
Device Voltage (V)	+4.5	+4.5
Current (mA)	25	25

1) OIP3 is measured with two tones at an output power of +0 dBm/tone separated by 1 MHz.

### Schematic

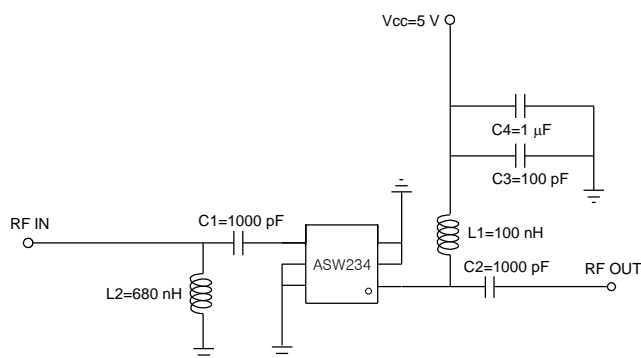

### Board Layout (FR4, 40x40 mm<sup>2</sup>, 0.8T)

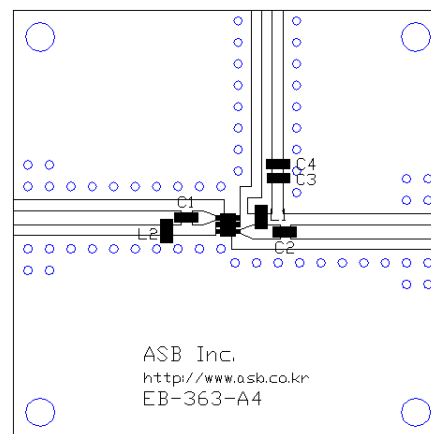

### S-parameters & K-factor

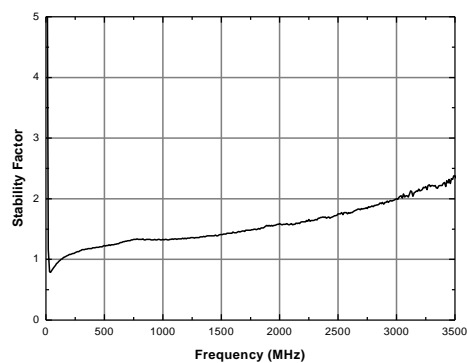
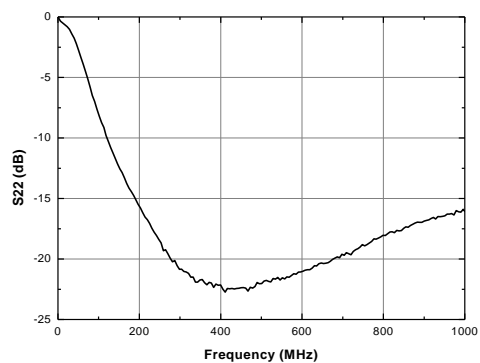
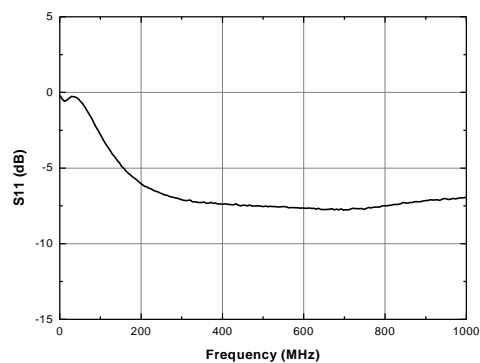
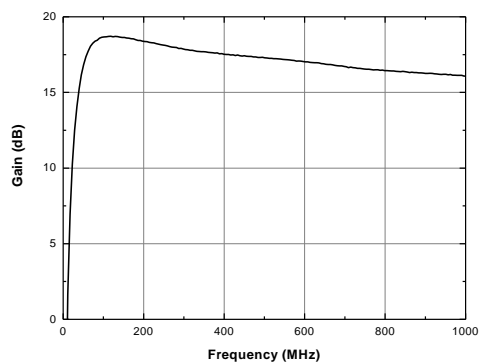

### APPLICATION CIRCUIT

WLAN

5000 ~ 6000 MHz

+5 V

Frequency (MHz)	5000	5500	6000
Magnitude S21 (dB)	10.0	10.0	9.7
Magnitude S11 (dB)	-10	-12	-15
Magnitude S22 (dB)	-10	-10	-13
Output P1dB (dBm)	15.0	14.5	14.0
Output IP3 <sup>1)</sup> (dBm)	27.0	28.0	24.5
Noise Figure (dB)	2.8	3.3	3.9
Device Voltage (V)	+5	+5	+5
Current (mA)	55	55	55

1) OIP3 is measured with two tones at an output power of +0 dBm/tone separated by 1MHz.

### Schematic

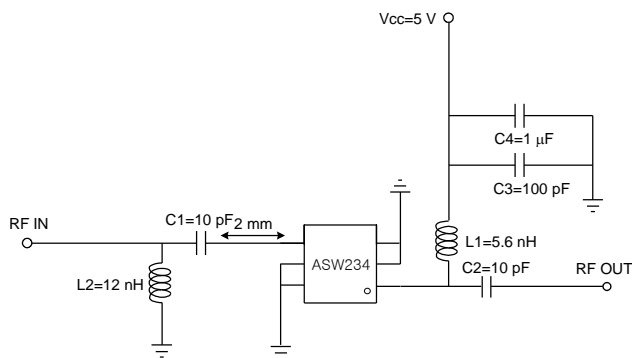

### Board Layout (FR4, 40x40 mm<sup>2</sup>, 0.8T)

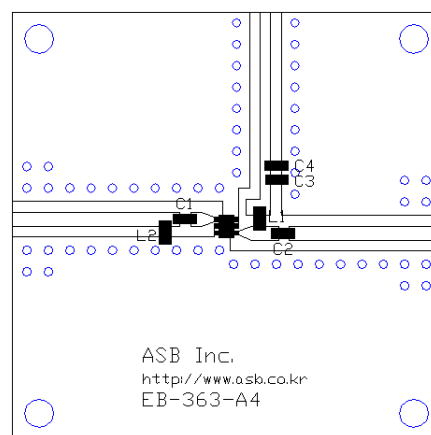

### S-parameters & K-factor

