

VI TELEFILTER**Filter specification****TFS 374B****1/5****Measurement condition**

Ambient temperature: 23 °C
 Input power level: 5 dBm
 Terminating impedances
 for input: 210 Ω || -5.2 pF
 for output: 305 Ω || -3.4 pF

Characteristics

Remark:

The reference level for the relative attenuation a_{rel} of TFS374B is the minimum of the pass band attenuation a_{min} . This value is defined as the insertion loss a_e . The centre frequency f_C is the arithmetic mean value of the upper and lower frequencies at the 3 dB filter attenuation level relative to the insertion loss a_e . The given values for the relative attenuation a_{rel} and the group delay ripple have to be reached at the frequencies given below, even if the centre frequency f_C is shifted due to the temperature coefficient of frequency TC_f in the operating temperature range and due to a production tolerance for the centre frequency f_C .

D a t a		typ. value	tolerance/limit
Insertion loss (Reference level)	a_e	8,7 dB	max. 10 dB
Nominal frequency	f_N	-	374,000 MHz
Centre frequency	f_C	374,000 MHz	-
3 dB bandwidth	BW	23 MHz	min. 17 MHz
Relative attenuation	a_{rel}		
f_N ... $f_N \pm 7$ MHz	7 MHz	0,8 dB	max 1 dB
$f_N \pm 7$ MHz ... $f_N \pm 8,5$ MHz	8,5 MHz	-	max 3 dB
$f_N - 100$ MHz ... $f_N - 33$ MHz	33 MHz	54 dB	min 45 dB
$f_N - 33$ MHz ... $f_N - 22$ MHz	22 MHz	53 dB	min 40 dB
$f_N - 22$ MHz ... $f_N - 16,5$ MHz	16,5 MHz	40 dB	min 30 dB
$f_N + 16,5$ MHz ... $f_N + 22$ MHz	22 MHz	44 dB	min 30 dB
$f_N + 22$ MHz ... $f_N + 43$ MHz	43 MHz	48 dB	min 35 dB
$f_N + 43$ MHz ... $f_N + 100$ MHz	100 MHz	49 dB	min 40 dB
Group delay ripple in $f_N \pm 7$ MHz	7 MHz	40 ns	max 100 ns
Triple transit suppression		40 dB	min 30 dB
Operating temperature range			- 10 °C ... + 85 °C
Storage temperature range			- 40 °C ... + 85 °C
Temperature coefficient of frequency	TCf	-94 ppm/K	-
Input power level			max 10 dBm

Generated: _____

Checked / approved: _____

VI TELEFILTER
 Potsdamer Straße 18
 D 14 513 TELTOW / Germany
 Tel: (+49) 3328 4784-0 / Fax: (+49) 3328 4784-30
 E-Mail: tft@telefilter.com

Vectron International, Inc.
 267 Lowell Road
 Hudson, NH 03051 / USA
 Tel: (603) 598-0070 Fax: (603) 598-0075
 E-Mail: vti@vtinh.com

VI TELEFILTER reserves the right to make changes to the product(s) and/or information contained herein without notice. No liability is assumed as a result of their use or application. No rights under any patent accompany the sale of any such product(s) or information.

Construction and pin configuration
(All dimensions in mm)

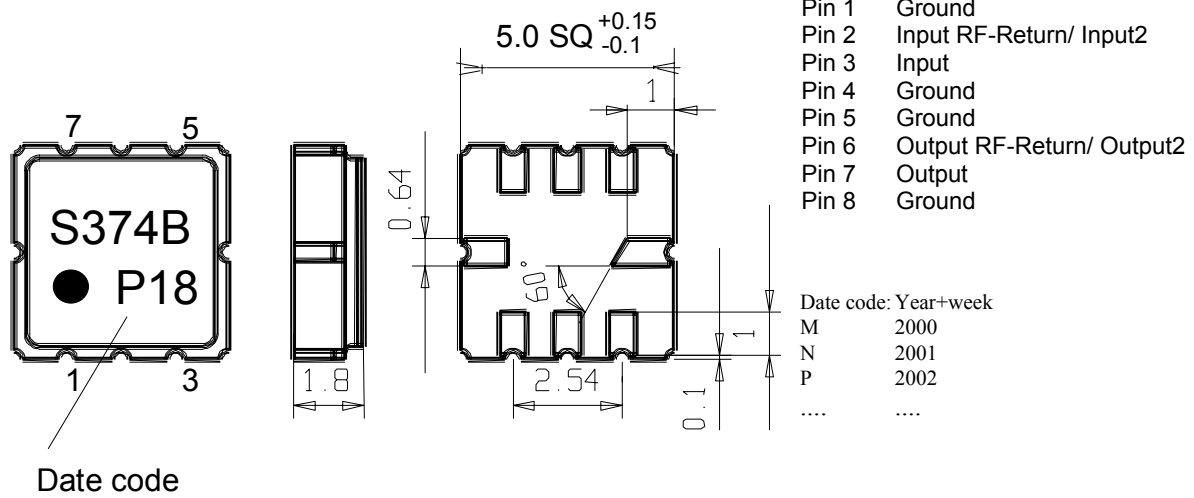

50 Ω Test circuit 1 (unbalanced)

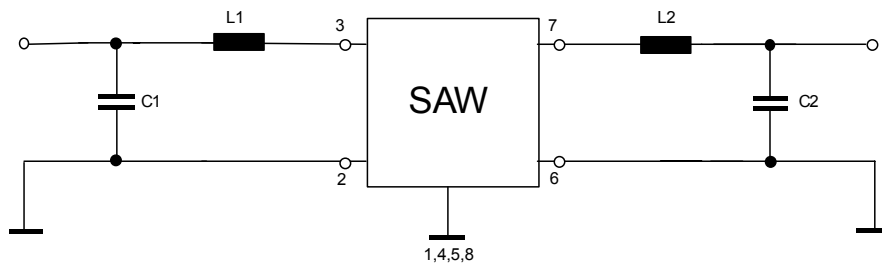

Stability characteristics

After the following tests the filter shall meet the whole specification:

1. Shock: 500g, 18 ms, half sine wave, 3 shocks each plane;
DIN IEC 68 T2 - 27
2. Vibration: 10 Hz to 500 Hz, 0,35 mm or 5g respectively, 1 octave per min, 10 cycles per plan, 3 plans;
DIN IEC 68 T2 - 6
3. Change of temperature: -55 °C to 125°C / 30 min. each / 10 cycles
DIN IEC 68 part 2 – 14 Test N
4. Resistance to solder heat (reflow): reflow possible: twice max.;
for temperature conditions, please refer to the attached "Air reflow temperature conditions" on page 4;

Packing

Tape & Reel: IEC 286 - 3, with exception of value for N and minimum bending radius;
tape type II, embossed carrier tape with top cover tape on the upper side;

max. pieces of filters per reel: 3000
reel of empty components at start: min 300 mm
reel of empty components at start including leader: min 500 mm
trailer: min 300 mm

Tape (all dimensions in mm)

W : 12 ± 0,3
Po : 4 ± 0,1
Do : 1,5 + 0,1
E : 1,75 ± 0,1
F : 5,5 ± 0,05
G (min) : 0,75
P2 : 2 ± 0,05
P1 : 8 ± 0,10
D1(min) : 1,5
Ao : 5,30 ± 0,1
Bo : 5,30 ± 0,1
CT : 9,5 ± 0,1

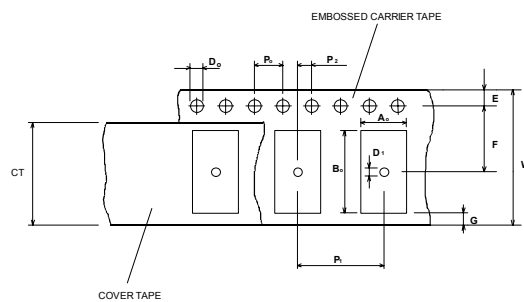
**Reel (all dimensions in mm):**

A : 330
W1 : 12,4 + 2,0
W2 (max) : 18,4
N (min) : 50
C : 13 ± 0,2

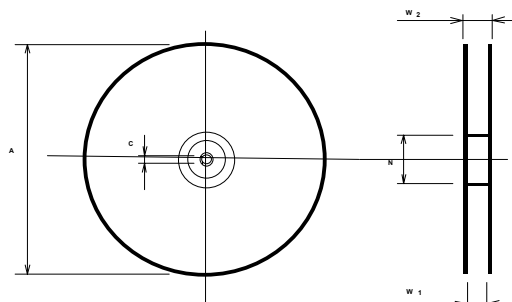

The minimum bending radius is 45 mm. The mounting surface of the filters faces the bottom side of the embossed carrier tape. Markings on the filters can be read if the upper side of the carrier tape is regarded with the sprocket holes on its right.

VI TELEFILTER
Potsdamer Straße 18
D 14 513 TELTOW / Germany
Tel: (+49) 3328 4784-52 / Fax: (+49) 3328 4784-30
E-mail: tft@telefilter.com

Vectron International, Inc.
267 Lowell Road
Hudson, NH 03051 / USA
Phone: (603) 598-0070 Fax: (603) 598-0075
e-mail: vti@vtinh.com

Air reflow temperature conditions

1st and 2nd air reflow profile

Name:	pre-heating periods	main-heating periods	peak temperature
Temperature:	150 °C - 170 °C	over 200 °C	255 °C ± 5 °C
Time:	60 sec. - 90 sec.	20 sec. - 25 sec.	

Chip-mount air reflow profile

Table for temperature vs. time during the air reflow process

Tolerance of temperatures: ± 5 °C

time / sec.	temperature / °C	time / sec.	temperature / °C
0	23	140	160
10	34	150	161
20	46	160	164
30	60	170	170
40	80	180	180
50	103	190	205
60	121	195	230
70	134	200	255
80	143	205	230
90	150	210	205
100	154	215	180
110	156	220	165
120	158	230	140
130	159	240	120

VI TELEFILTER**Filter specification****TFS 374B****5/5**

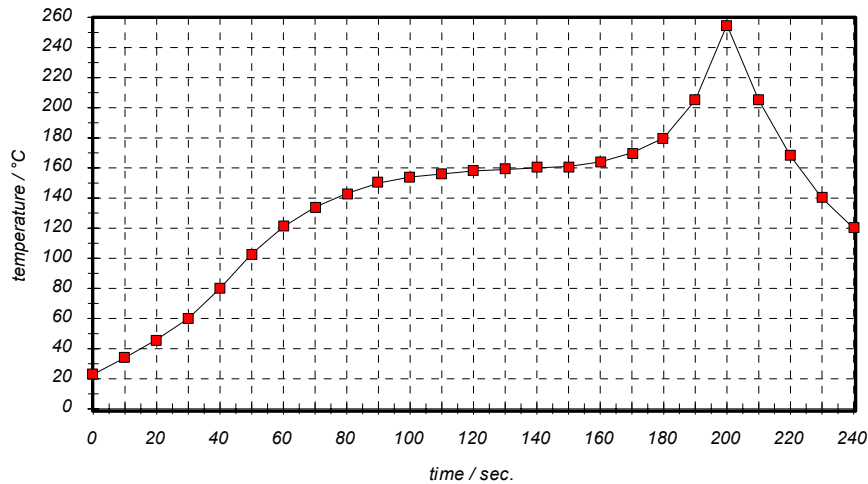
History

version	reason of changes	name	date
1.0	generate specification	Steiner	02.05.2002
2.0	terminating impedances added	Steiner	14.10.2002

VI TELEFILTER
Potsdamer Straße 18
D 14 513 TELTOW / Germany
Tel: (+49) 3328 4784-52 / Fax: (+49) 3328 4784-30
E-mail: tft@telefilter.com

Vectron International, Inc.
267 Lowell Road
Hudson, NH 03051 / USA
Phone: (603) 598-0070 Fax: (603) 598-0075
e-mail: vti@vtinh.com