



When precision matters...™

TW1015/TW1017 Embedded GPS L1 Antenna

The TW1015 by Tallysman Wireless is low cost, small, high performance, low profile, embedded GPS L1 antenna, specially designed for OEM industrial, military, precision positioning and timing applications.

The TW1015 features a high performance custom tuned ceramic patch element, a very low noise amplifier (LNA) and a tight band-pass SAW filter. An optional tight pre-filter is available with part number TW1017 to protect against saturation by high level sub-harmonics and L-Band signals.

The TW1015/TW1017 is specifically tailored for OEM applications where excess gain can cause feedback or pass-band response ripple. It covers the GPS L1 and SBAS (WAAS /EGNOS/MSAS) frequency band (1572.5 to 1578 MHz), and it offers great circular polarized signal reception, multipath rejection and out of band signal rejection.

The built-in 35mm circular ground plane can be augmented with host system ground surfaces. Tallysman offers custom services to assist with integration of OEM modules into an end user solution.

Applications

- High Accuracy & Mission Critical GPS
- Precision Agriculture, Mining & Construction
- Military & Security
- Avionics
- Law Enforcement & Public Safety
- Fleet Management & Asset Tracking



TW1015 Dimensions (mm)

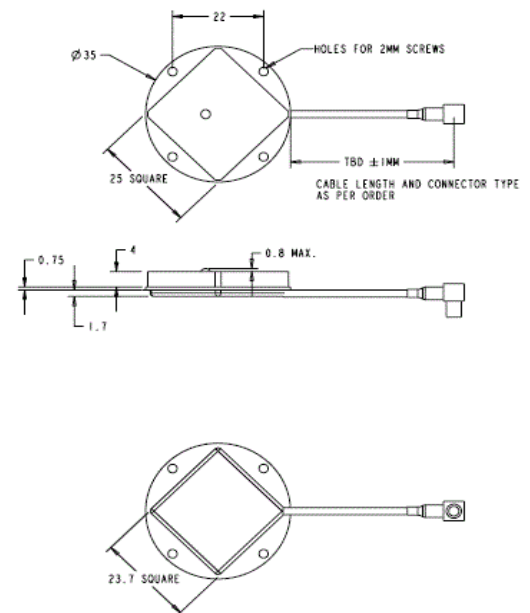

Features

- Very low noise LNA: 1 dB
- Great axial ratio: <4dB at Zenith
- High rejection SAW filter
- LNA gain: 16 dB typ.
- Low current: 5 mA typ.
- ESD circuit protection: 15 KV
- Wide Supply voltage: fixed 2.5V to 16V

Benefits

- Low Profile: 7.25mm
- Great multipath rejection
- Increase system accuracy
- Excellent signal to noise ratio
- Great out of band signal rejection
- Compact form factor
- RoHS compliant



When precision matters...™

TW1015/TW1017 Embedded GPS L1 Antenna

Specifications At; Vcc = 3V, over full bandwidth, T=25°C

Antenna

Architecture	Custom single-feed ceramic patch
Polarization	RHCP
Antenna Gain (70mm ground plane)	4 dBic at 90°
Axial Ratio	4 dB at 90°, 6dB at 20°
Frequency/Bandwidth (-10dB Return Loss)	1575.42MHz +/- 10MHz

Electrical

Architecture	TW1015	LNA stage 1 -> SAW filter
	TW1017	SAW Pre-filter ->LNA stage 1
Gain (1575.42 to 1606 MHz)		15dB min., TW1015; 12dB min, TW1017,
Filtered LNA Frequency Bandwidth (3dB)		1575.42MHz +/- 10MHz
Out-of-Band Rejection		<1500MHz >32dB. (TW1015) >50dB (TW1017)
		<1550MHz >25dB. >50 dB
		>1640MHz >35dB. >70 dB
VSWR (at LNA output)		<1.5:1
Noise Figure		TW1015:1 dB typ. TW1017: 3.5dB typ.
Supply Voltage Range (over coaxial cable)		+2.5VDC to 16VDC nominal (12 VDC recommended max)
Supply Current		5mA typ.
ESD Circuit protection		15KV air discharge

Mechanicals & Environmental

Mechanical Size	35mm dia. x 7.5mm
Cable	1.48mm OD,
Operating Temp. Range	-40°C to +85°C
Weight	30 g
Attachment Method	Adhesive or screw mount
Environmental	RoHS compliant
Shock	Vertical axis: 50G, other axes: 30G
Vibration	3 axis, sweep = 15 min, 10 to 200 Hz sweep: 3G
Warranty	One year - parts and labour

Ordering Information

Legacy Part Numbers:

TW1015 - GPS L1 antenna, 33-1015-xx-yyyy-zz TW1017 - 33-1017-xx-yyyy-zz

Please refer to the Ordering Guide (<http://www.tallysman.com/orderingguide.php>) for the current and complete list of available connectors.

Tallysman Wireless Inc

106 Schneider Road, Unit 3
Ottawa ON K2K 1Y2 Canada

Tel 613 591 3131 Fax 613 591 3121 sales@tallysman.com

The information provided herein is intended as a guide only and is subject to change without notice. This document is not to be regarded as a guarantee of performance. Tallysman Wireless Inc. hereby disclaims any or all warranties and liabilities of any kind. © 2011 Tallysman Wireless Inc. All rights reserved. Rev 2.3