

AMT-A0087 2 GHz to 18 GHz Broadband High Power Amplifier Module

Data Sheet

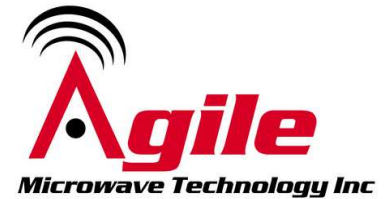

Features

- 2 GHz to 18 GHz Frequency Range
- Typical P1dB power > +31 dBm (1.2W)
- Gain 34 dB Typical
- Gain Flatness ± 2 dB Typical
- Internally Regulated
- Low Spurious < -80 dBc typical
- Operates from +15V Supply and -5V
- Unconditionally Stable
- State-of-the-Art GaAs Technology

Description

The AMT-A0087 is a +31 dBm P1dB Broadband power amplifier in a compact size. The performance is achieved through the use of AMTI's proprietary matching technology and latest in GaAs technology. The amplifier I/Os are Internally matched to 50 Ohms and are DC blocked. The AMT-A0087 is ideal for use as extending power range of test equipment, EW systems or where broadband amplification and power are required in a Hi-Rel communications system for Commercial or Military applications

Applications

- Radar
- Test Equipment
- EW Systems
- Lab Applications

MAXIMUM RATINGS¹

Parameter	Symbol	Units	MIN	MAX
Operating Temperature – Case	T _{MO}	° C	-10	+55
Storage Temperature - Case	T _{MS}	° C	-55	+125
RF Input power (CW)	P _{in}	dBm		+18
Die T _{Junction}	T _J	° C		+150
Positive Supply Voltage	V _{+SS}	V		+16

Appropriate Heat sink must be used

1.Stresses above those listed under "Absolute Maximum Rating" may cause permanent damage to the device. This is a stress rating only and functional operation of the device at these or any other conditions above those indicated in the operational sections of this specification is not implied. Exposure to absolute maximum rating conditions for extended periods may affect device reliability.

ELECTRICAL SPECIFICATIONS @ 23°C

Parameter	Conditions	Units	MIN	Typical	MAX
Frequency Range		GHz	2		18
Gain	Small Signal	dB	30	34	
Gain Flatness		dB		±2	±2.8
Gain Flatness 1 GHz BW		dB		±0.5	±0.9
Noise Figure		dB		6	
Output Power (P1dB)		dBm	30	31	
OIP3	OIP3 measured @ 9 GHz Two tone F1-F2= 10MHz	dB		40	
Spurious	Measured with input terminated Output connected to spectrum analyzer and BW adjusted to achieve dynamic range required	dBm /dBc		-80	-75
RF Input Impedance	Reference to 50 ohms VSWR			1.8:1	2.2:1
RF Output Impedance	Reference to 50 ohms VSWR			1.8:1	2.2:1
Supply Voltage Positive: Negative:		V		+15 -5V	
Supply Current Positive: Negative:		mA		720	20

Notes:

1/ Unconditional Stability

Tested Parameter @ 23C Gain, Gain Flatness, NF, P1dB @ 2,10 and 18 GHz, Spurious, VSWR, Current

Tested Parameters @ 0C & +60C Gain, Gain Flatness, Spurious, current

Customized configurations of the above specifications are available

Package Outline M055: SMA Connectorized (inches)

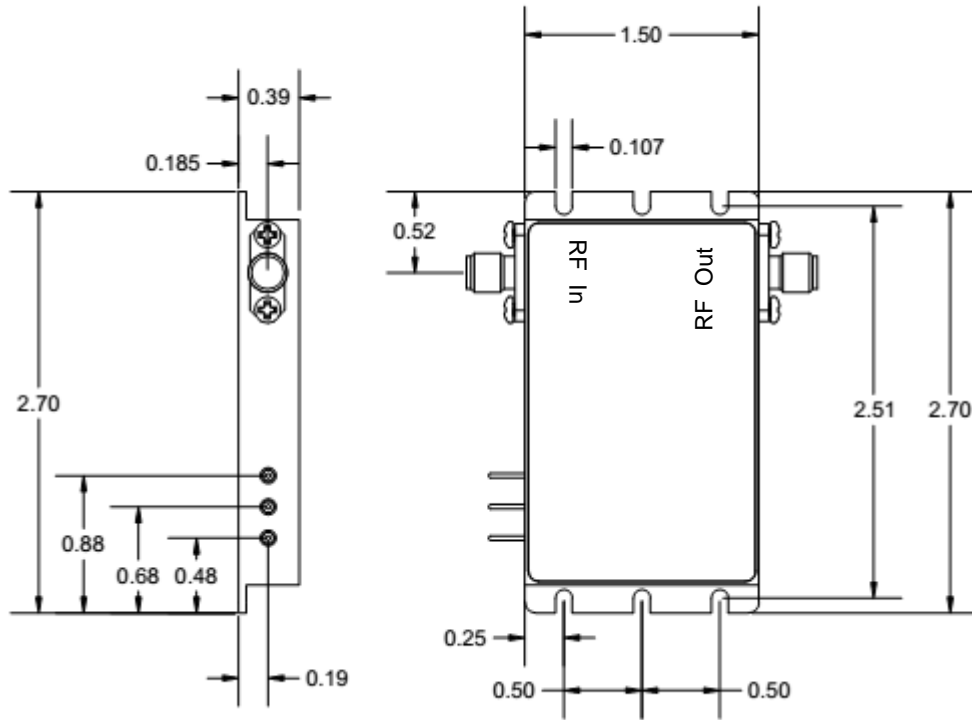

Field replaceable SMA Connectors

Note: The unit must be attached to proper heat sink with thermal interface material (Thermal Pad or Thermal Grease)

Model Number	Description	Hermeticity	Package
AMT-A0087	SMA Female	Non-Hermetic	Outline: M055

Contact us for custom configurations and special requirements.

Our highly experienced team of engineers can quickly identify and implement innovative solutions using latest technology to improve performance and reduce cost.

- Add additional functionality: Input limiter, Temperature compensation, Amplitude/Phase matching, Amplitude/Phase Tracking, Automatic Gain control, Gain sloping, Bypass path, Specific supply voltage, Regulation, Power detector, Health status, and others
- Integrated: Filters, Switches, Limiter, Digital attenuator, Phase shifter, Microcontroller, Multiple amplifiers, Switch matrix, Comb generators and others
- Mechanical: Custom packages - Surface Mount, Connectorized, Waveguide, Carrier, Drop-in, Hermetic and others

Agile Microwave Technology Inc is the logical choice for all your commercial or military RF/Microwave components/module requirements.

Contact Information:

**101 Bloomingdale Road
Hicksville, NY 11801**

Phone: (516) 931-1760

Fax: (212) 374-1153

info@agilemwt.com

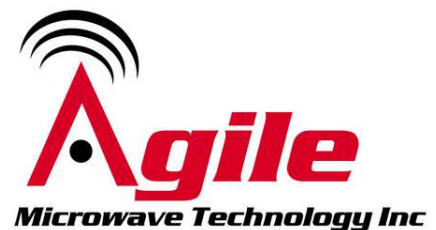

www.agilemwt.com

AMTI reserves the right to change at any time without notice the design, specifications, function/form or availability of its products described herein. The buyer/customer has the responsibility to validate the performance for their applications. No liability is assumed as result of use of this product and no patent licenses are implied. AMTI reserves all rights .