

Features

- 24.5 dB Gain at 2 GHz
- 36 dBm OIP3 at 2 GHz
- 19 dBm P1dB at 2 GHz
- 0.95 dB NF at 2 GHz
- Two-stage LNA

Description

ASL19D is a two-stage LNA, which has a low noise, high gain, and high linearity over a wide range of frequency up to 5 GHz. It is also suitable for use in the low noise amplifier block of the mobile wireless systems of PCS, WCDMA, WiBro, WiMAX, and WLAN so on. The amplifier is available in a DFN6 package and passes the stringent DC, RF, and reliability tests.

Typical Performance

(Supply Voltage = +3 & +5 V, T_A = +25 °C, Z₀ = 50 Ω)

Parameters	Units	Typical						
		2000	2400	2700	3500	2000	2400	2700
Testing Frequency	MHz	2000	2400	2700	3500	2000	2400	2700
Gain	dB	24.5	21.5	20.0	16.0	24.0	19.5	19.0
S11	dB	-18	-16	-13	-18	-18	-14	-11
S22	dB	-10	-11	-14	-10	-9	-11	-12
Output IP3 ¹⁾	dBm	36	36.5	37.0	37.5	38.0	39.0	39.0
Noise Figure	dB	0.95	1.10	1.25	1.60	0.90	1.10	1.25
Output P1dB	dBm	19	19	19	20	23	23	23
Current	mA	90	90	90	90	90	90	90
Device Voltage	V	+3	+3	+3	+3	+4.6	+4.6	+4.6

1) OIP3 is measured with two tones at an output power of +5 dBm/tone separated by 1MHz.

Product Specifications

Parameters	Units	Min	Typ	Max
Frequency	MHz		2000	
Gain	dB	23.0	24.5	
S11	dB		-18	
S22	dB		-10	
Output IP3	dBm	34	36	
Noise Figure	dB		0.95	1.10
Output P1dB	dBm	18	19	
Current	mA	60	90	120
Device Voltage	V		+3	

100% in-house DC & RF testing is done on packaged products before taping

Absolute Maximum Ratings

Parameters	Rating
Operating Case Temperature	-40 to +85 °C
Storage Temperature	-40 to +150 °C
Device Voltage	+5.5 V
Operating Junction Temperature	+150 °C
Input RF Power (CW, 50 Ω matched) ¹⁾	+22 dBm
Thermal Resistance	88 °C/W

1) Please find the max. input power data from http://www.asb.co.kr/pdf/Maximum_Input_Power_Analysis.pdf

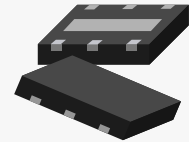

Package Style: DFN6

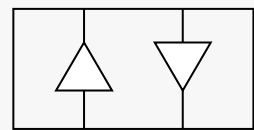

Application Circuit

- 1700 ~ 2700 MHz
- 3500 MHz

Pin Configuration

Pin No.	Function
1	1 st (2 nd) stage RF IN
2,5	GND or NC
3	2 nd (1 st) stage RF OUT
4	2 nd (1 st) stage RF IN
6	1 st (2 nd) stage RF OUT

Outline Drawing

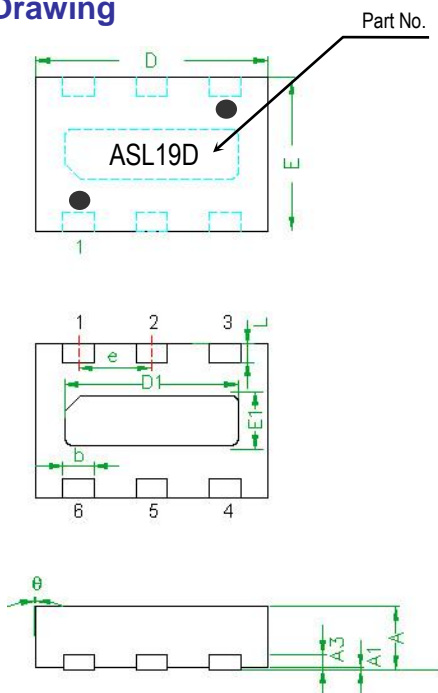

Symbols	Dimensions (In mm)		
	MIN	NOM	MAX
A	0.80	0.85	0.90
A1	0	0.010	0.030
A3	---	0.20REF	---
b	0.35	0.40	0.45
D	2.95	3.00	3.03
D1	---	2.25BSC	---
E	1.95	2.00	2.03
E1	---	0.65BSC	---
e	---	0.95BSC	---
L	0.275	0.325	0.375
θ	-12	---	0

Pin No.	Function	Pin No.	Function.
1	1 st (2 nd) stage RF IN	4	2 nd (1 st) stage RF IN
2	GND or NC	5	GND or NC
3	2 nd (1 st) stage RF OUT	6	1 st (2 nd) stage RF OUT

Note: 1. Backside metal paddle is RF and DC ground.

2. Both of pin 1 and pin 4 is marked for reference and can be used as an RF input since ASL19D has two chips in a package in which dies are in 180° symmetry.

Mounting Recommendation (In mm)

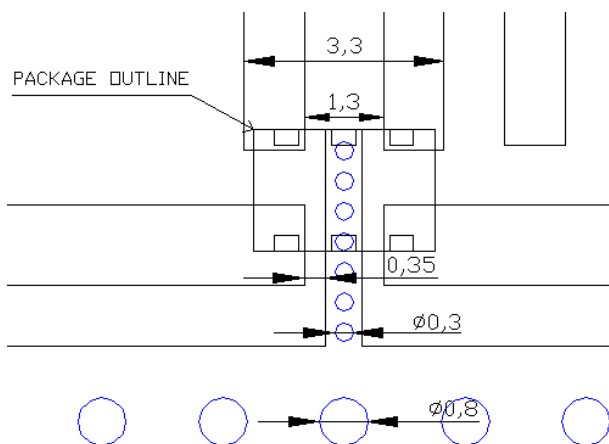

ESD Classification & Moisture Sensitivity Level

ESD Classification

HBM	Class 1A Voltage Level: 400 V
MM	Class A Voltage Level: 50 V

CAUTION: ESD-sensitive device!

Moisture Sensitivity Level (MSL)

Level 3 at 260 °C reflow

APPLICATION CIRCUIT

Wide Band
1700 ~ 2700 MHz
+3 V

Frequency (MHz)	1700	2000	2400	2700
Magnitude S21 (dB)	27.0	24.5	21.5	20.0
Magnitude S11 (dB)	-18	-18	-16	-13
Magnitude S22 (dB)	-10	-10	-11	-14
Output P1dB (dBm)	19	19	19	19
Output IP3 ¹⁾ (dBm)	35.0	36.0	36.5	37.0
Noise Figure (dB)	0.90	0.95	1.10	1.25
Device Voltage (V)	+3			
Current (mA)	90			

1) OIP3 is measured with two tones at an output power of +5 dBm/tone separated by 1 MHz.

Schematic

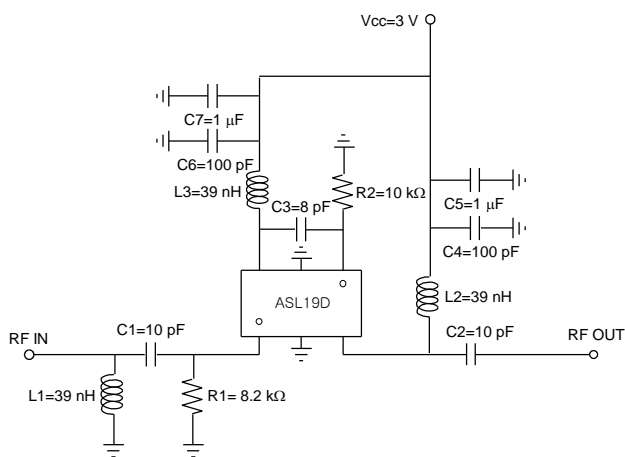

Board Layout (FR4, 40x40 mm², 0.8T)

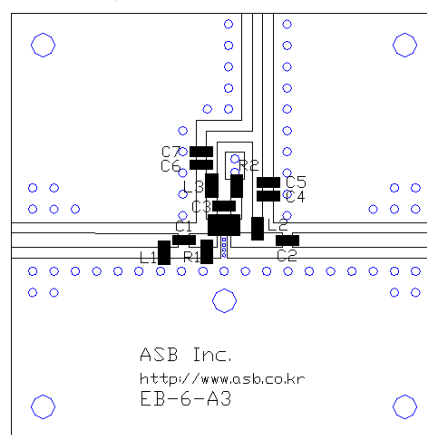

S-parameters & K-factor

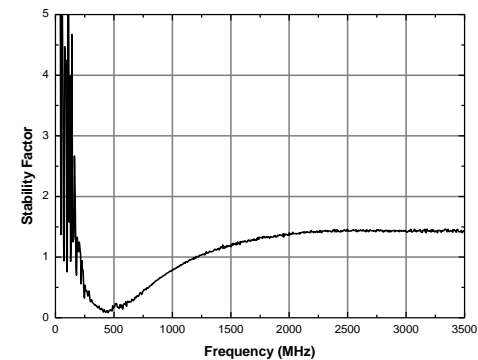
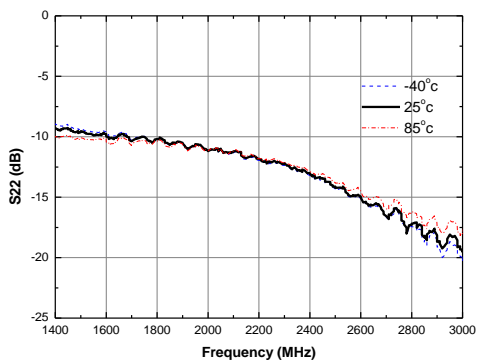
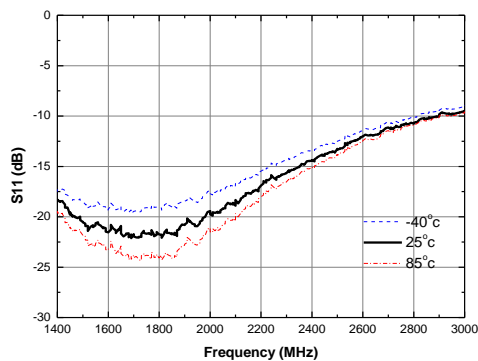
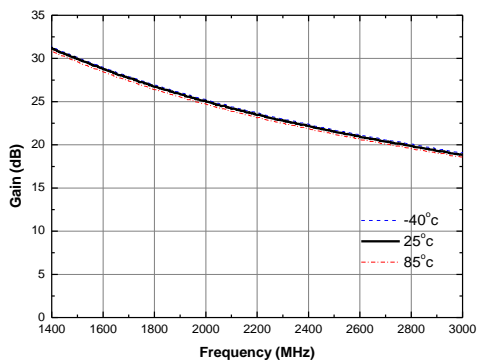

Current vs. Temperature

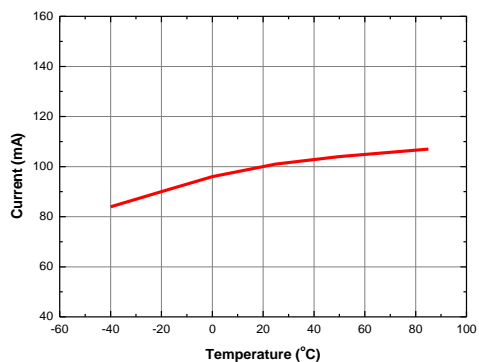

Gain vs. Temperature

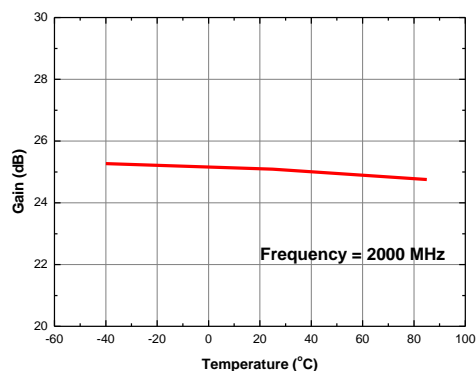

P1dB vs. Temperature

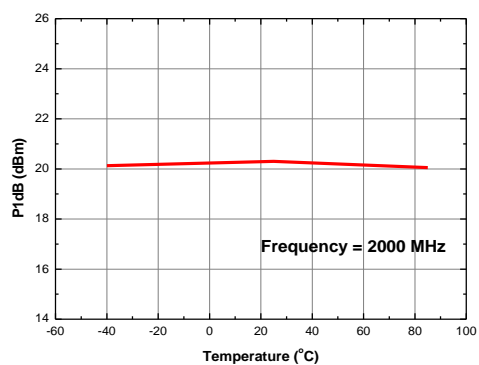

Output IP3 vs. Temperature

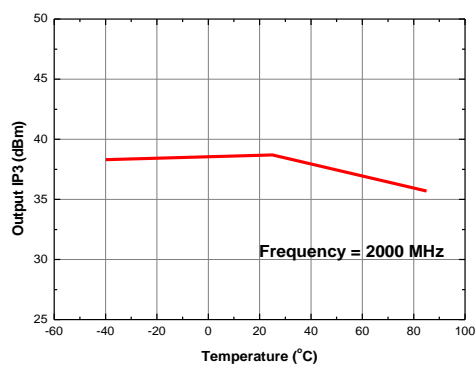

Output IP3 vs. Tone Power (Frequency = 2000 MHz)

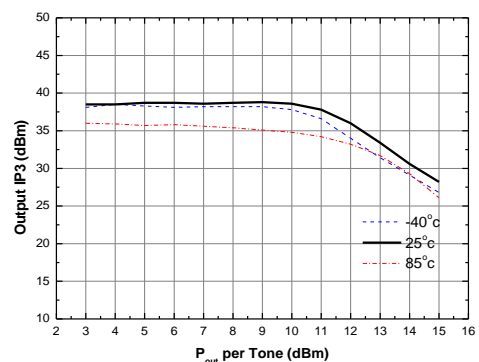

APPLICATION CIRCUIT

Wide Band

1700 ~ 2700 MHz

+5 V

Frequency (MHz)	1700	2000	2400	2700
Magnitude S21 (dB)	26.5	24.0	19.5	19.0
Magnitude S11 (dB)	-18	-18	-14	-11
Magnitude S22 (dB)	-9	-9	-11	-12
Output P1dB (dBm)	23	23	23	23
Output IP3 ¹⁾ (dBm)	36.5	38.0	39.0	39.0
Noise Figure (dB)	0.85	0.90	1.10	1.25
Device Voltage (V)	+4.6			
Current (mA)	90			

1) OIP3 is measured with two tones at an output power of +5 dBm/tone separated by 1 MHz.

Schematic

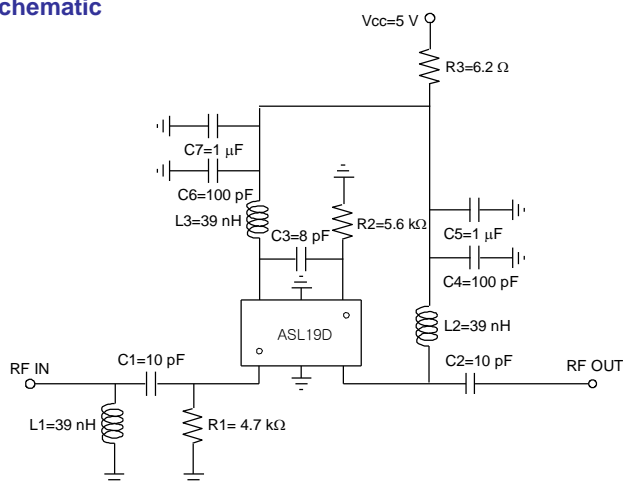

Board Layout (FR4, 40x40 mm², 0.8T)

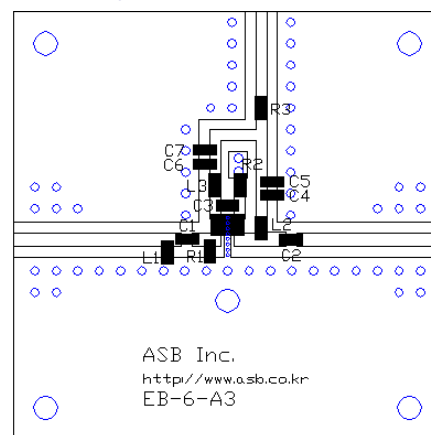

S-parameters & K-factor

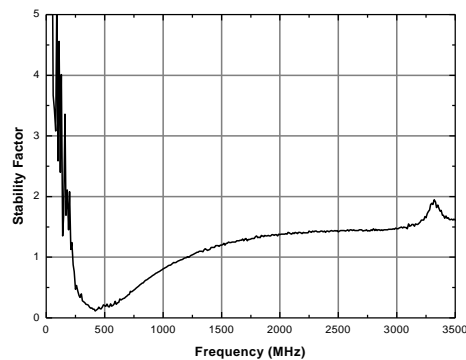
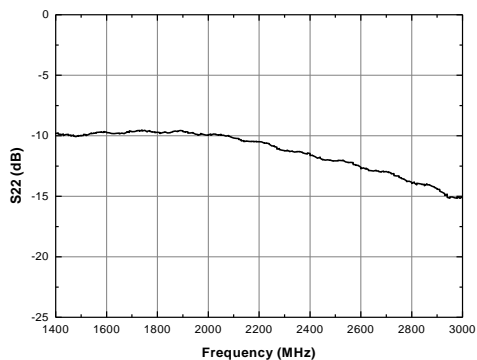
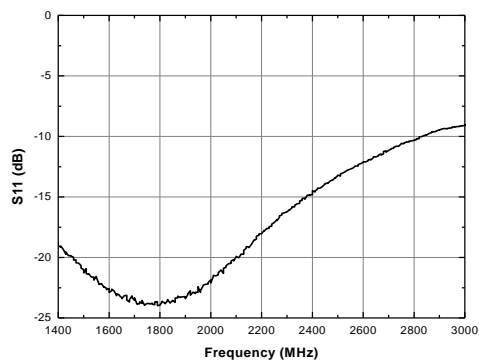
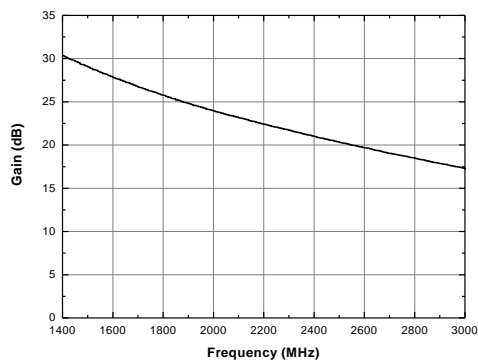

APPLICATION CIRCUIT

WiMAX

3500 MHz

+3 V

Frequency (MHz)	3500
Magnitude S21 (dB)	16
Magnitude S11 (dB)	-18
Magnitude S22 (dB)	-10
Output P1dB (dBm)	20
Output IP3 ¹⁾ (dBm)	37.5
Noise Figure (dB)	1.6
Device Voltage (V)	+3
Current (mA)	90

1) OIP3 is measured with two tones at an output power of +5 dBm/tone separated by 1 MHz.

Schematic

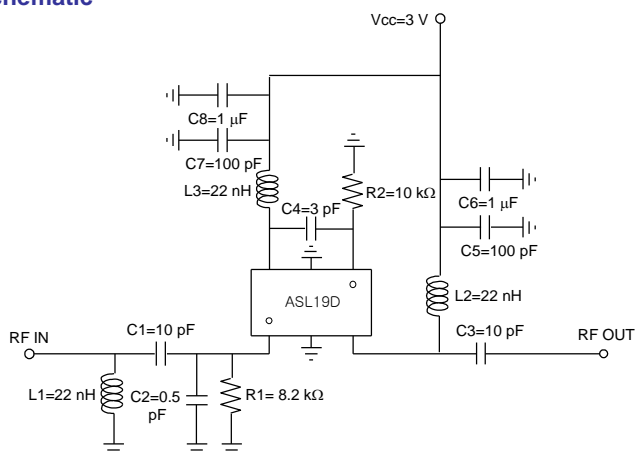

Board Layout (FR4, 40x40 mm², 0.8T)

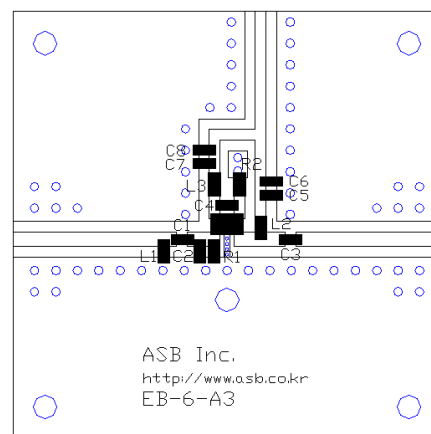

S-parameters & K-factor

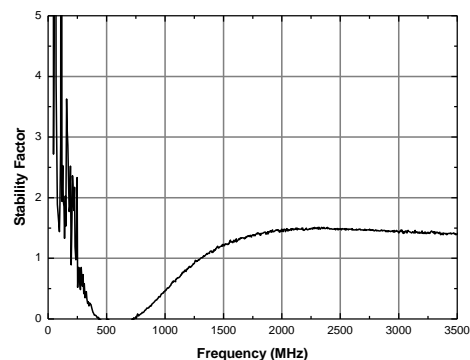
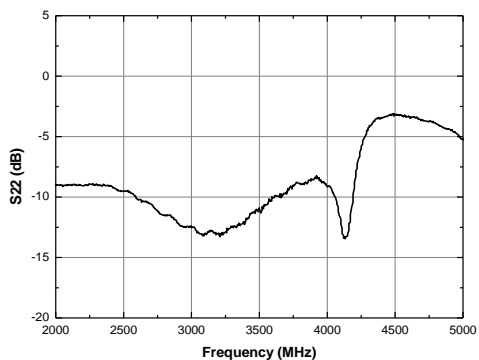
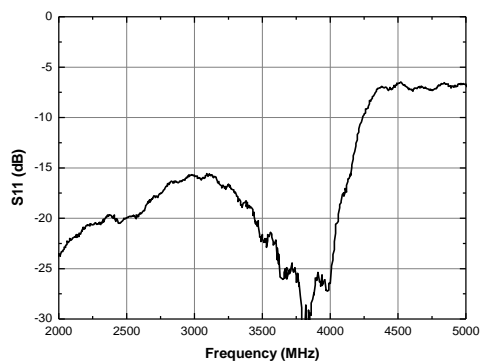
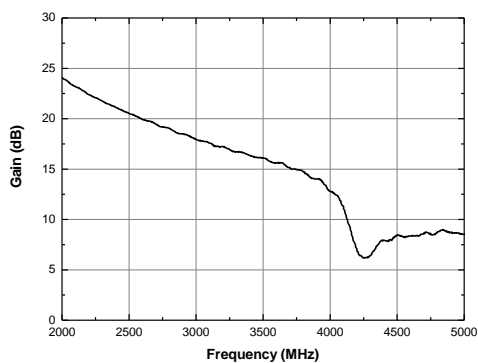

Recommended Soldering Reflow Profile

