

## GaAs MMIC VSAT Power Amplifier 2.0 W 5.9 - 6.4 GHz

Rev. V5

### Features

- High Linear Gain: 30 dB Typical
- High Saturated Output Power: +33 dBm Typ.
- High Power Added Efficiency: 26% Typ.
- 50  $\Omega$  Input/Output Broadband Matched
- Lead-Free Ceramic Bolt Down Package
- RoHS\* Compliant and 260°C Reflow Compatible

### Description

The AM42-0040 is a three-stage MMIC power amplifier in a lead-free, ceramic bolt down style hermetic package. The AM42-0040 employs an internally matched monolithic chip with internally decoupled Gate and Drain bias networks. The AM42-0040 is designed to be operated from a constant current Drain supply. By varying the Gate bias voltage, the saturated output power performance of this device can be tailored for various applications.

The AM42-0040 is designed for use as an output stage or driver amplifier for C-band VSAT transmitter systems. This amplifier employs a fully monolithic chip and requires a minimum of external components.

The AM42-0040 is fabricated using a mature 0.5 micron GaAs MESFET process. The process features full passivation for increased performance and reliability. This product is 100% RF tested to ensure compliance to performance specifications.

### Ordering Information

Part Number	Package
AM42-0040	Ceramic Bolt Down

### Functional Schematic

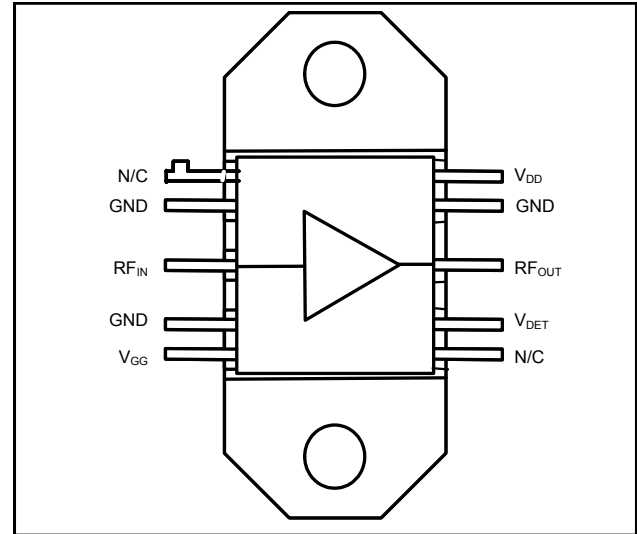

### Pin Configuration

Pin No.	Pin Name	Description
1	N/C	No Connection
2	GND	DC and RF Ground
3	RF In	RF Input
4	GND	DC and RF Ground
5	V <sub>GG</sub>	Gate Supply
6	N/C	No Connection
7	V <sub>DET</sub>	Detector
8	RF Out	RF Output
9	GND	DC and RF Ground
10	V <sub>DD</sub>	Drain Supply

\* Restrictions on Hazardous Substances, European Union Directive 2002/95/EC.

## GaAs MMIC VSAT Power Amplifier 2.0 W 5.9 - 6.4 GHz

Rev. V5

**Electrical Specifications:  $T_A = 25^\circ\text{C}$ ,  $V_{DD} = +9\text{ V}$ ,  $V_{GG}$  adjusted for  $I_{DD} = 1050\text{ mA}$**

Parameter	Test Conditions	Units	Min.	Typ.	Max.
Linear Gain	$P_{IN} \leq -10\text{ dBm}$	dB	27	30	—
Input VSWR	$P_{IN} \leq -10\text{ dBm}$	Ratio	—	2.3:1	2.7:1
Output VSWR	$P_{IN} \leq -10\text{ dBm}$	Ratio	—	3.0:1	—
Output Power	$P_{IN} = +10\text{ dBm}$ , $I_{DD} = 1050\text{ mA Typ.}$	dBm	31.7	33.0	34.5
Output Power vs. Frequency	$P_{IN} = +10\text{ dBm}$ , $I_{DD} = 1050\text{ mA Typ.}$	dB	—	1.0	1.5
Output Power vs. Temperature (with respect to $T_A = 25^\circ\text{C}$ )	$P_{IN} = +10\text{ dBm}$ , $I_{DD} = 1050\text{ mA Typ.}$ $T_A = -40^\circ\text{C to } +70^\circ\text{C}$	dB	—	$\pm 0.4$	—
Drain Bias Current	$P_{IN} = +10\text{ dBm}$	mA	900	1050	1100
Gate Bias Voltage	$P_{IN} = +10\text{ dBm}$ , $I_{DD} = 1050\text{ mA Typ.}$	V	-2.4	-1.2	-0.4
Gate Bias Current	$P_{IN} = +10\text{ dBm}$ , $I_{DD} = 1050\text{ mA Typ.}$	mA	—	5	20
Thermal Resistance	$25^\circ\text{C Heat Sink}$	$^\circ\text{C/W}$	—	5.6	—
Second Harmonic	$P_{IN} = +10\text{ dBm}$ , $I_{DD} = 1050\text{ mA Typ.}$	dBc	—	-35	—
Third Harmonic	$P_{IN} = +10\text{ dBm}$ , $I_{DD} = 1050\text{ mA Typ.}$	dBc	—	-45	—
$V_{DET}$		V	2	—	—

### Absolute Maximum Ratings <sup>1,2,3</sup>

Parameter	Absolute Maximum
Input Power	+23 dBm
$V_{DD}$	+12 Volts
$V_{GG}$	-3 Volts
$V_{DD} - V_{GG}$	+12 Volts
$I_{DD}$	1700 mA
Channel Temperature	$-40^\circ\text{C to } +85^\circ\text{C}$
Storage Temperature	$-65^\circ\text{C to } +150^\circ\text{C}$

- Exceeding any one or combination of these limits may cause permanent damage to this device.
- M/A-COM Technology does not recommend sustained operation near these survivability limits.
- Case Temperature (TC) =  $+25^\circ\text{C}$ .

### Typical Bias Configuration <sup>4,5,6,7,8</sup>

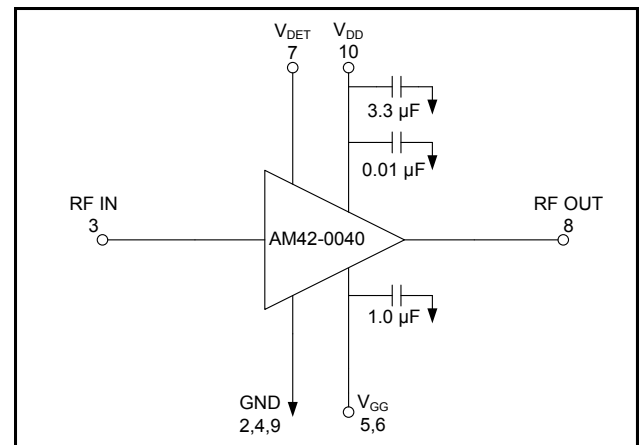

- Nominal bias is obtained by first connecting -2.4 volts to pin 5 ( $V_{GG}$ ), followed by connection +9 volts to pin 10 ( $V_{DD}$ ). Note sequence. Adjust  $V_{GG}$  for a drain current of 1050 mA typical.
- RF ground and thermal interface is the flange (case bottom). Adequate heat sinking is required.
- No DC bias voltage appears at the RF ports.
- For optimum IP3 performance, the  $V_{DD}$  bypass capacitors should be placed within 0.5 inches of the  $V_{DD}$  leads.
- Resistor and capacitors surrounding the amplifier are suggestions and not included as part of the AM42-0040.

**Typical Performance Curves @ +25°C**

*Linear Gain vs. Frequency*

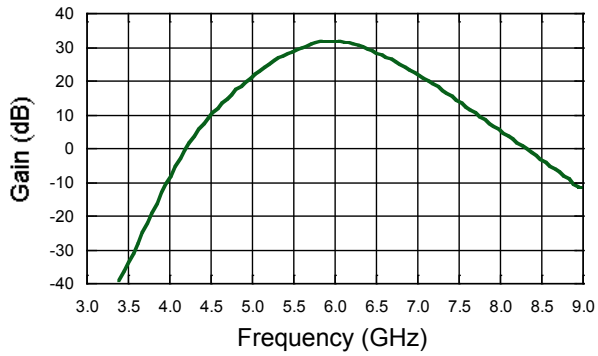

*Input and Output Return Loss vs. Frequency*

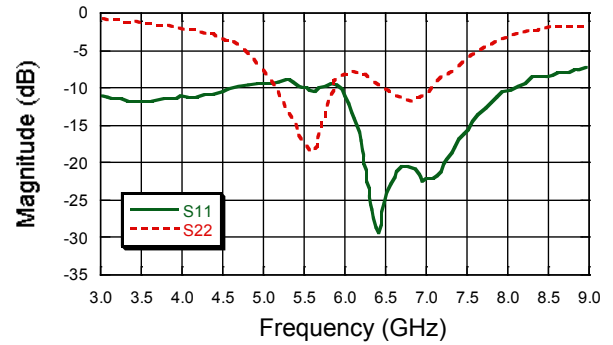

*Output Power vs. Frequency @  $P_{IN} = +10$  dBm*

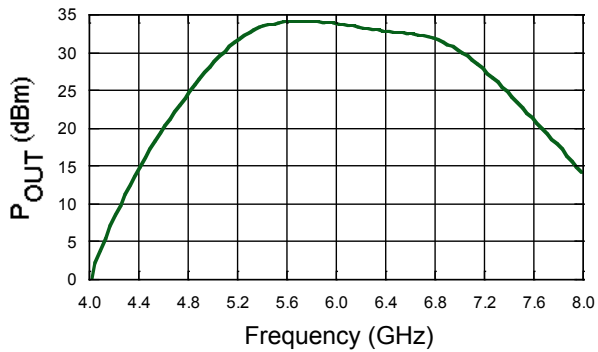

*PAE vs. Frequency @  $P_{IN} = +10$  dBm*

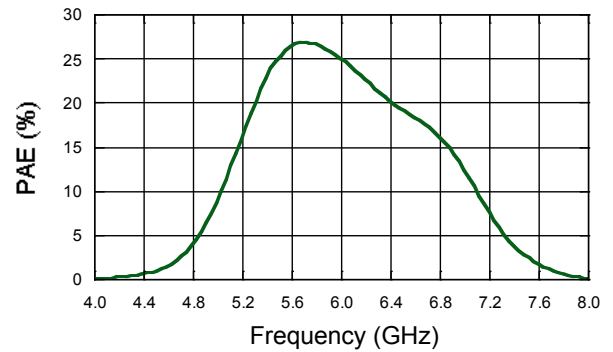

*Output Power vs. Input Power @ 6.15 GHz*

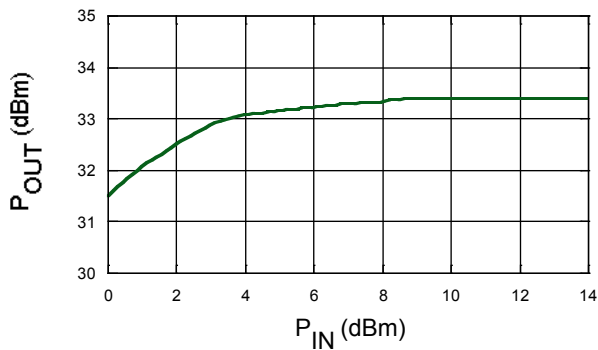

*PAE vs. Input Power @ 6.15 GHz*

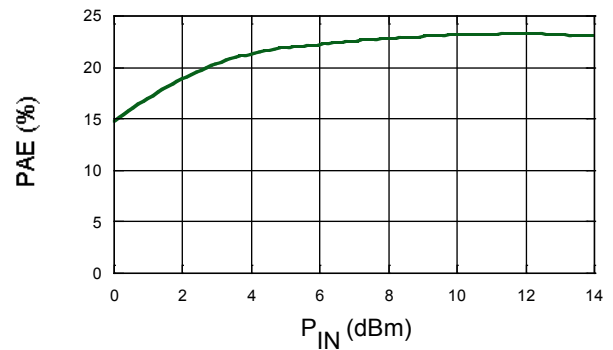

## Lead-Free CR-15<sup>†</sup>

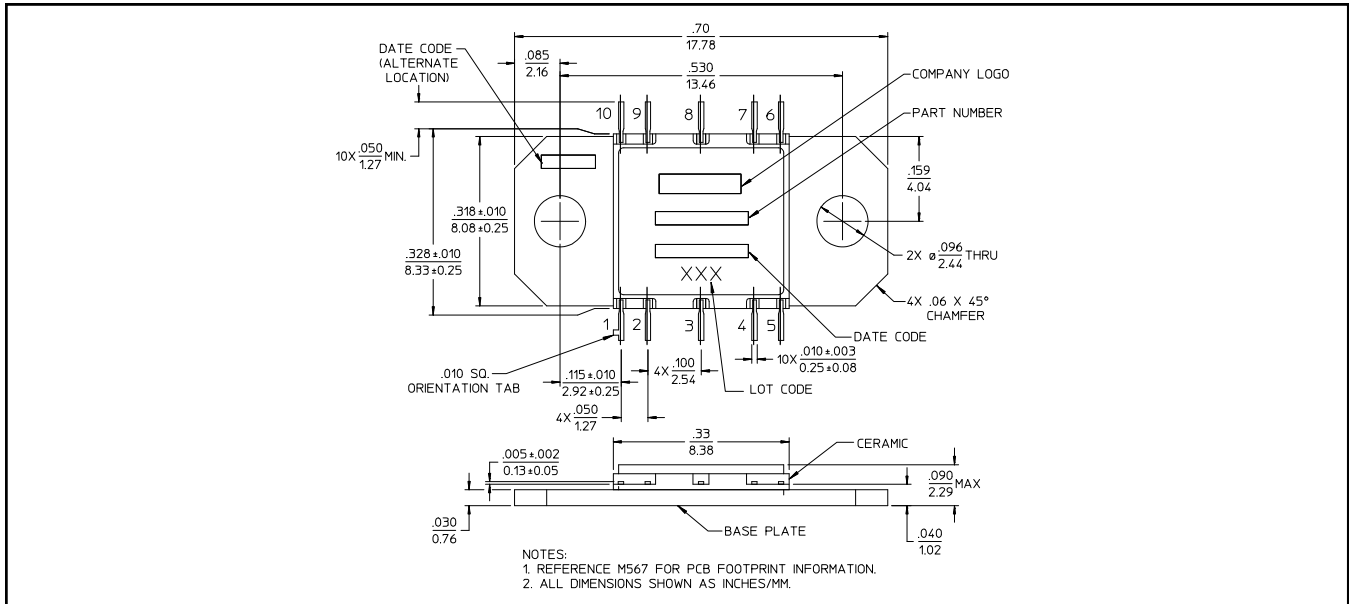

<sup>†</sup> Reference Application Note M538 for lead-free solder reflow recommendations.  
 Meets JEDEC moisture sensitivity level 1 requirements.

## Handling Procedures

Please observe the following precautions to avoid damage:

## Static Sensitivity

Gallium Arsenide Integrated Circuits are sensitive to electrostatic discharge (ESD) and can be damaged by static electricity. Proper ESD control techniques should be used when handling these devices.

M/A-COM Technology Solutions Inc. All rights reserved.

Information in this document is provided in connection with M/A-COM Technology Solutions Inc ("MACOM") products. These materials are provided by MACOM as a service to its customers and may be used for informational purposes only. Except as provided in MACOM's Terms and Conditions of Sale for such products or in any separate agreement related to this document, MACOM assumes no liability whatsoever. MACOM assumes no responsibility for errors or omissions in these materials. MACOM may make changes to specifications and product descriptions at any time, without notice. MACOM makes no commitment to update the information and shall have no responsibility whatsoever for conflicts or incompatibilities arising from future changes to its specifications and product descriptions. No license, express or implied, by estoppel or otherwise, to any intellectual property rights is granted by this document.

THESE MATERIALS ARE PROVIDED "AS IS" WITHOUT WARRANTY OF ANY KIND, EITHER EXPRESS OR IMPLIED, RELATING TO SALE AND/OR USE OF MACOM PRODUCTS INCLUDING LIABILITY OR WARRANTIES RELATING TO FITNESS FOR A PARTICULAR PURPOSE, CONSEQUENTIAL OR INCIDENTAL DAMAGES, MERCHANTABILITY, OR INFRINGEMENT OF ANY PATENT, COPYRIGHT OR OTHER INTELLECTUAL PROPERTY RIGHT. MACOM FURTHER DOES NOT WARRANT THE ACCURACY OR COMPLETENESS OF THE INFORMATION, TEXT, GRAPHICS OR OTHER ITEMS CONTAINED WITHIN THESE MATERIALS. MACOM SHALL NOT BE LIABLE FOR ANY SPECIAL, INDIRECT, INCIDENTAL, OR CONSEQUENTIAL DAMAGES, INCLUDING WITHOUT LIMITATION, LOST REVENUES OR LOST PROFITS, WHICH MAY RESULT FROM THE USE OF THESE MATERIALS.

MACOM products are not intended for use in medical, lifesaving or life sustaining applications. MACOM customers using or selling MACOM products for use in such applications do so at their own risk and agree to fully indemnify MACOM for any damages resulting from such improper use or sale.

5

---

*M/A-COM Technology Solutions Inc. (MACOM) and its affiliates reserve the right to make changes to the product(s) or information contained herein without notice.*  
Visit [www.macom.com](http://www.macom.com) for additional data sheets and product information.