

**RA BNC Male Connector Crimp/Solder Attachment
 For LMR-200 Cable**

Configuration

Connector BNC Male

Electrical Specifications*

| Description | Min | Typ | Max | Units |
|-----------------|-----|-----|--------|-------|
| Frequency Range | DC | | 4 | GHz |
| Impedance | | 50 | | Ohms |
| VSWR | | | 1.35:1 | |
| AC DWV | | | 1,500 | Vrms |

* Values at 25°C, sea level

Mechanical Specifications

Temperature

Operating Range -65 to +165 deg C

Size

Length 0.863 in [21.92 mm]
 Width/Dia. 1.076 in [27.33 mm]

Connector

Type BNC Male
 Contact Material and Plating Brass, Gold
 Contact Plating Specification 30µ In. Minimum
 Coupling Nut Material and Plating Brass, Nickel
 Body Material and Plating Brass, Nickel
 Dielectric Type PTFE

Compliance Certifications (visit www.FairviewMicrowave.com for current document)

RoHS Compliant Yes



Features:

- Specification: MIL-C-39012
- Interface: LMR-200
- Attachment: Crimp/Solder
- Body Style: Right Angle

Fairview Microwave
 1130 Junction Dr. #100
 Allen, TX 75013
 Tel: 1-800-715-4396 / (972) 649-6678
 Fax: (972) 649-6689
www.fairviewmicrowave.com
sales@fairviewmicrowave.com

Plotted and Other Data

Notes:

- Values at +25 °C, sea level

RA BNC Male Connector Crimp/Solder Attachment For LMR-200 Cable from Fairview Microwave is in-stock and available to ship same-day. All of our RF/microwave products are available off-the-shelf from our ISO 9001:2008 certified facilities in Allen, Texas. Fairview Microwave is RF on-demand.

For additional information on this product, please click the following link: [RA BNC Male Connector Crimp/Solder Attachment For LMR-200 Cable SC6000](#)

URL: <http://www.fairviewmicrowave.com/bnc-male-standard-lmr-200-connector-sc6000-p.aspx>

The information contained in this document is accurate to the best of our knowledge and representative of the part described herein. It may be necessary to make modifications to the part and/or the documentation of the part, in order to implement improvements. Fairview Microwave reserves the right to make such changes as required. Unless otherwise stated, all specifications are nominal. Fairview Microwave does not make any representation or warranty regarding the suitability of the part described herein for any particular purpose, and Fairview Microwave does not assume any liability arising out of the use of any part or documentation.

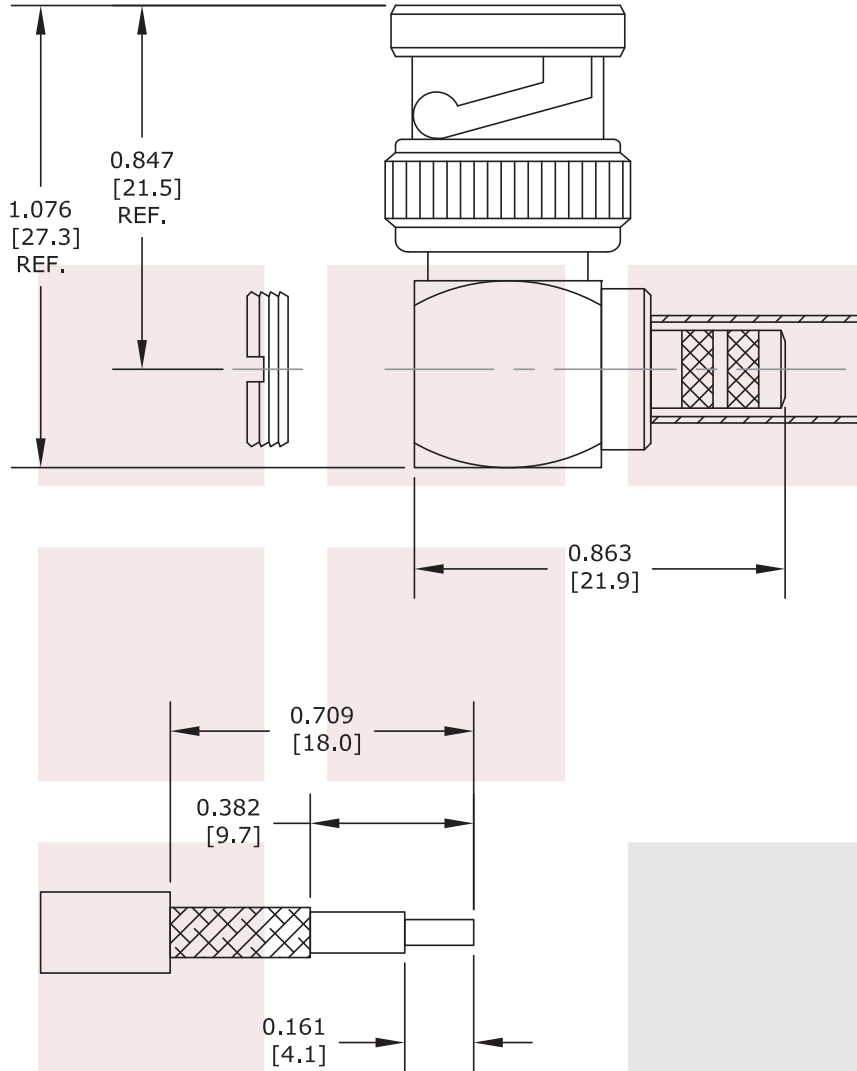

STRIPPING DIMENSIONS

CRIMP SIZE REQUIRED

CONTACT PIN: SOLDER
 FERRULE: .213" HEX CRIMP TOOL

| | | | | | |
|---|------------------|---|-----------|------|--|
| FAIRVIEW MICROWAVE INC. ALLEN, TX 75013 WWW.FAIRVIEWMICROWAVE.COM | | NOTES: 1. UNLESS OTHERWISE SPECIFIED ALL DIMENSIONS ARE NOMINAL. 2. ALL SPECIFICATIONS ARE SUBJECT TO CHANGE WITHOUT NOTICE AT ANY TIME. 3. DIMENSIONS ARE IN INCHES [mm]. | | | |
| TITLE RA BNC Male Connector Crimp/Solder Attachment For LMR-200 Cable | DWG NO SC6000 | CAGE CODE 3FKR5 | | | |
| CAD FILE 080814 | SHEET | SCALE N/A | SIZE A | 2233 | |