

- **Low Insertion Loss**
- **5.0 X 7.0 mm Surface-Mount Case**
- **Complies with Directive 2002/95/EC (RoHS)**



Absolute Maximum Ratings

Rating	Value	Units
Maximum Incident Power in Passband	+10	dBm
Maximum DC Voltage Between any Two Terminals	30	VDC
Storage Temperature Range in Tape and Reel	-40 to +85	°C
Maximum Soldering Profile	265 °C for 10 s	

SF2131B

**92.16 MHz
SAW Filter**

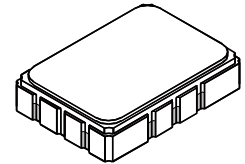

SMP-03

Electrical Characteristics

Characteristic	Sym	Notes	Min	Typ	Max	Units
Nominal Center Frequency	f_c	1	92.16			MHz
1.5 dB Passband Bandwidth			20			MHz
Minimum Insertion Loss	IL_{MIN}	1, 2		9	10.0	dB
Attenuation Relative to IL_{MIN}	0 to 40.72 MHz	1, 3	42	50		dB
	40.72 to 66 MHz		45	49.5		
	61.44 to 122.88 MHz		52	56		
	109 to 143.6 MHz		40	45		
	143.6 to 153.6 MHz		56	60		
	218 to 1000 MHz		58	63		
Amplitude Ripple		1, 4		0.9	1.2	dB _{P-P}
Group Delay Ripple		1, 4		65	100	ns _{P-P}
1 dB Compression Point		1, 5	12	15		dBm
Input IP3		1	35	40		dBm
Operating Temperature Range		1	-40		+85	°C
Terminating Source/Load Impedance				50		ohm
Case Style	SMP-03 7 x 5 mm Nominal Footprint					
Lid Symbolization (YY=year, WW=week, S=shift) See note 4	RFM SF2131B YYWWS					



CAUTION: Electrostatic Sensitive Device. Observe precautions for handling.

NOTES:

1. Unless noted otherwise, all specifications apply over the operating temperature range with filter soldered to the specified demonstration board with impedance matching to 50 Ω and measured with 50 Ω network analyzer.
2. Unless noted otherwise, all frequency specifications are referenced to the nominal center frequency, f_c .
3. Rejection is measured as attenuation below the minimum IL point in the passband. Rejection in final user application is dependent on PCB layout and external impedance matching design. See Application Note No. 42 for details.
4. The design, manufacturing process, and specifications of this filter are subject to change.
5. US and international patents may apply.
6. Murata, stylized Murata logo, and Murata N.A., Inc. are registered trademarks of Murata Manufacturing Co., Ltd.

SF2131B I/O Impedance (matched) and Amplitude Plots

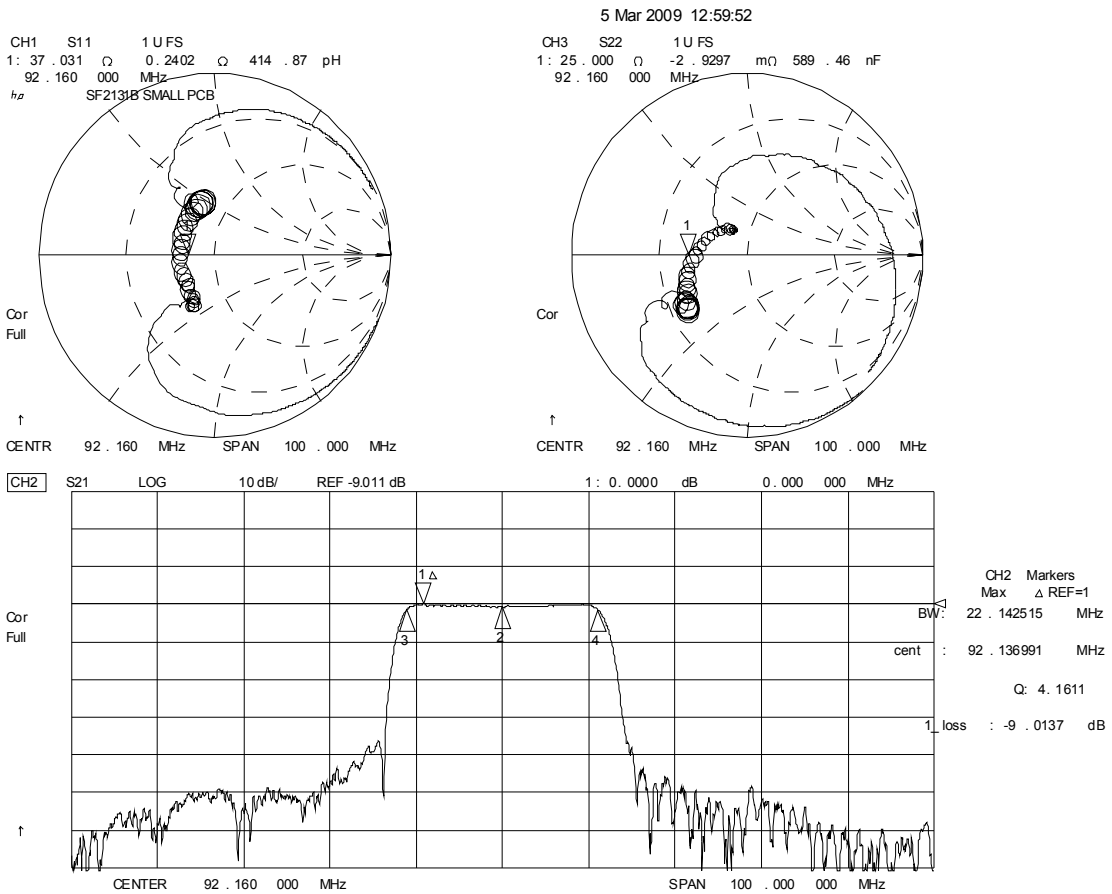

SF2131B Matching Network

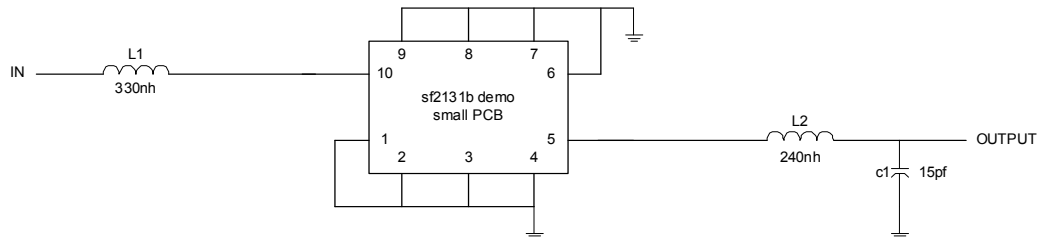

PCB	400-1608-001	small PCB, 5X7	PCB
IND	501-0782-331	0805, 330 nH	L1
IND	501-0782-241	0805, 240 nH	L2
CAP	501-1275-150	0805, 15 pF	C1

Tape and Reel Specifications

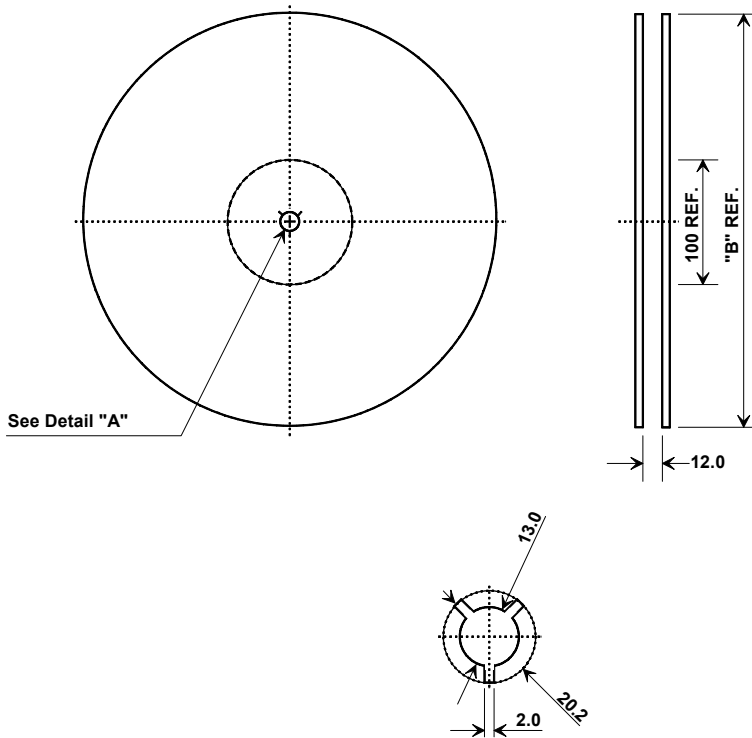

"B"		Quantity Per Reel
Inches	millimeters	
7	178	500
13	330	2000

COMPONENT ORIENTATION and DIMENSIONS

Carrier Tape Dimensions	
Ao	9.4 mm
Bo	7.4 mm
Ko	2.0 mm
Pitch	8.0 mm
W	16.0 mm

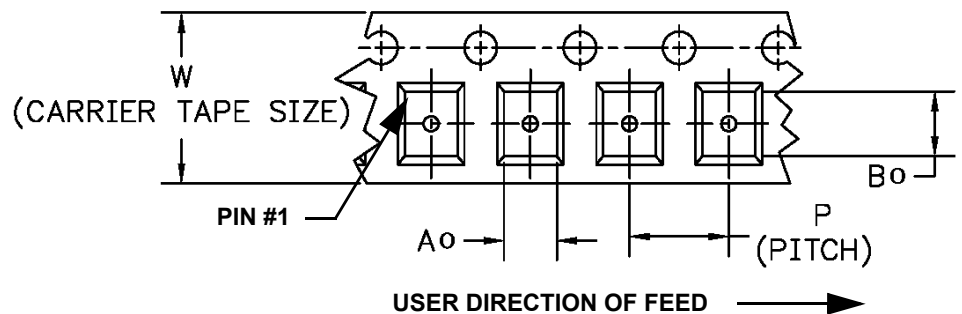
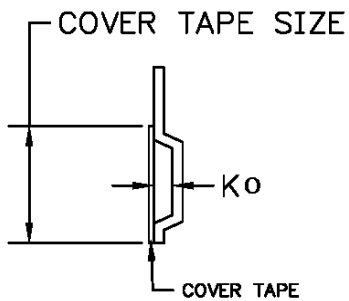

SMP-03 Case

10-Terminal Ceramic Surface-Mount Case

7 x 5 mm Nominal Footprint

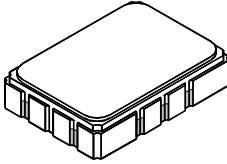

Recommended PCB Footprint

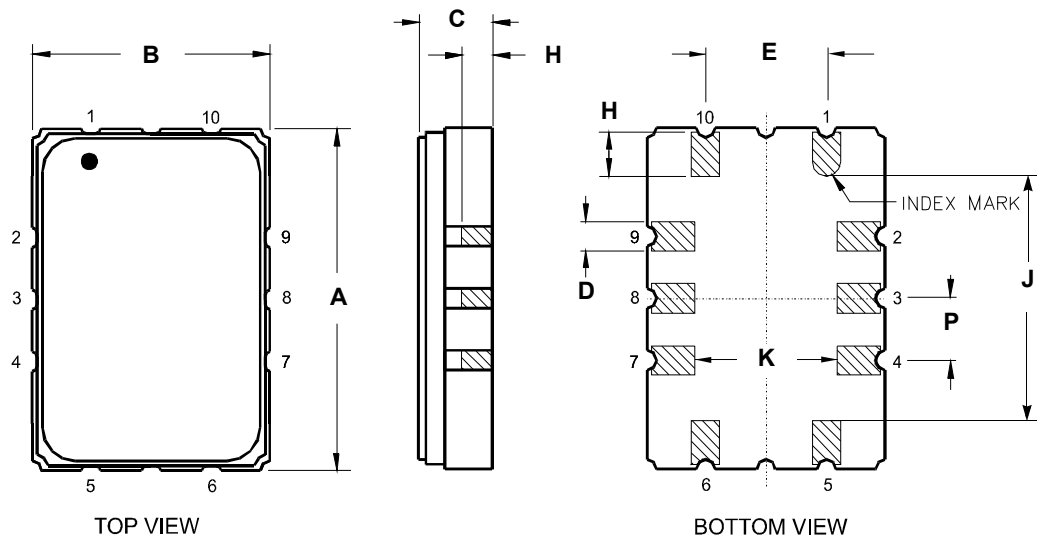
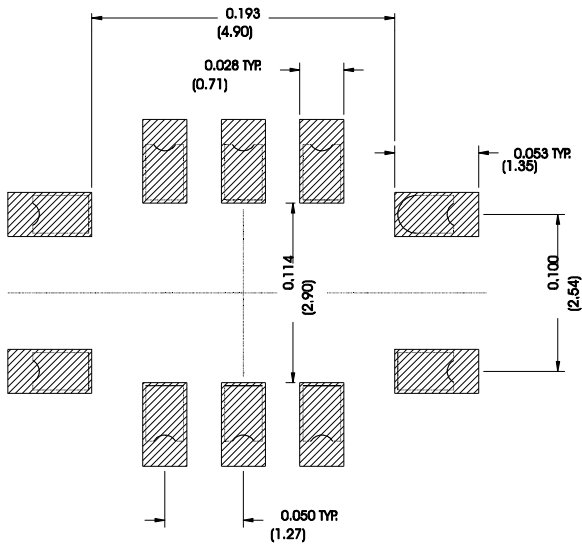

Case Dimensions						
Dimension	mm			Inches		
	Min	Nom	Max	Min	Nom	Max
A	6.80	7.00	7.20	0.268	0.276	0.283
B	4.80	5.00	5.20	0.189	0.197	0.205
C		1.65	2.00		0.065	0.079
D	.47	0.60	.73	0.019	0.024	0.029
E	2.41	2.54	2.67	0.095	0.100	0.105
H	0.87	1.0	1.13	0.034	0.039	0.044
J	4.87	5.00	5.13	0.192	0.197	0.202
K	2.87	3.00	3.13	0.113	0.118	0.123
P	1.14	1.27	1.40	0.045	0.050	0.055

Electrical Connections		
	Connection	Terminals
Port 1	Input or Return	10
	Return or Input	1
Port 2	Output or Return	5
	Return or Output	6
	Ground	All others
	Single-ended Operation	Return is ground
	Differential Operation	Return is hot

Materials	
Solder Pad Plating	0.3 to 1.0 μm Gold over 1.27 to 8.89 μm Nickel
Lid Plating	2.0 to 3.0 μm Nickel
Body	Al_2O_3 Ceramic
Pb Free	