

Features

- 3 Stage Driver Amplifier for 18/23 GHz Bands
- 23 dB Gain
- 33 dBm Output Third Order Intercept (OIP3)
- 21 dBm Output P1dB
- 2.8 dB Noise Figure
- Variable Gain with Adjustable Bias
- Lead-Free 4 mm 16-Lead PQFN Package
- RoHS* Compliant

Description

The MAAM-011132 is a packaged driver amplifier that operates from 17.7 - 23.6 GHz. The amplifier provides 23 dB small signal gain. The input and output are internally matched to 50 ohms with on-chip DC blocking capacitors. The 33 dBm output third order intercept point (OIP3) and 21 dBm output P1dB provide excellent linearity for transmit lineups.

The packaged amplifier comes in an industry standard lead free 4 mm QFN package. The device includes on-chip ESD protection structures and DC by-pass capacitors to ease the implementation and volume assembly of the packaged part.

The device is specifically designed for use in 18 and 23 GHz point-to-point radios for cellular backhaul applications.

Ordering Information^{1,2}

Part Number	Package
MAAM-011132-TR0500	500 Piece Reel
MAAM-011132-TR1000	1000 Piece Reel
MAAM-011132-000SMB	Sample Board

1. Reference Application Note M513 for reel size information.
2. All sample boards include 5 loose parts.

Functional Schematic

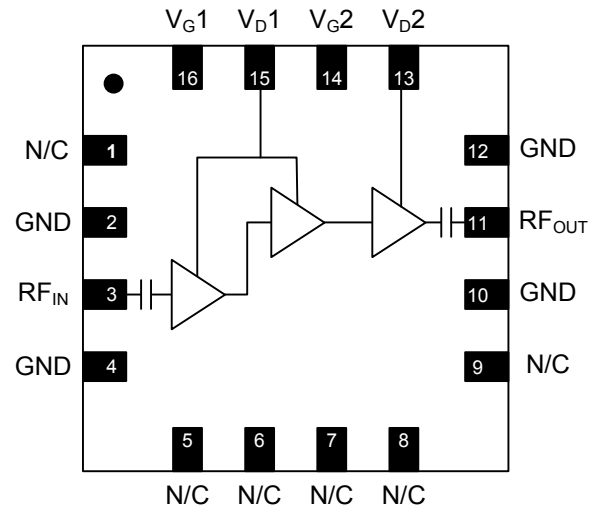

Pin Configuration³

Pin No.	Function	Pin No.	Function
1	No Connection	9	No Connection
2	Ground	10	Ground
3	RF Input	11	RF Output
4	Ground	12	Ground
5	No Connection	13	V _{D2}
6	No Connection	14	V _{G2}
7	No Connection	15	V _{D1}
8	No Connection	16	V _{G1}
		17	Paddle ⁴

3. For optimum RF performance, all N/C's should be terminated to ground.
4. The exposed pad centered on the package bottom must be connected to RF and DC ground.

* Restrictions on Hazardous Substances, European Union Directive 2011/65/EU.

Electrical Specifications⁵:

RF Freq: 17.7 - 23.6 GHz, $V_D = 4\text{ V}$, $I_{D1} = 90\text{ mA}$, $I_{D2} = 90\text{ mA}$, $T_A = +25^\circ\text{C}$

Parameter	Units	Min.	Typ.	Max.
Frequency Range (LO)	GHz	17.7	—	23.6
Gain	dB	20	23	—
Input Return Loss	dB	—	12	—
Output Return Loss	dB	—	12	—
Noise Figure	dB	—	2.8	—
Output P1dB	dBm	—	21	—
Output IP3	dBm	—	33	—

5. Apply gate voltages prior to drain voltages. Adjust V_{G1} and V_{G2} between -1.0 and -0.1 V to achieve specified drain current. Typical current, 180 mA = 90 (I_{D1}) + 90 (I_{D2})

Absolute Maximum Ratings^{6,7,8}

Parameter	Absolute Maximum
Drain Voltage	+4.3 V
Gate Bias Voltage ($V_{G1,2}$)	-1.5 V < V_G < 0 V
Input Power	+3 dBm
Storage Temperature	-55°C to +150°C
Operating Temperature	-40°C to +85°C
Junction Temperature	+150°C

- Exceeding any one or combination of these limits may cause permanent damage to this device.
- MACOM does not recommend sustained operation near these survivability limits.
- Operating at nominal conditions with $T_J \leq +150^\circ\text{C}$ will ensure $\text{MTTF} > 1 \times 10^6$ hours.

Handling Procedures

Please observe the following precautions to avoid damage:

Static Sensitivity

Gallium Arsenide Integrated Circuits are sensitive to electrostatic discharge (ESD) and can be damaged by static electricity. Proper ESD control techniques should be used when handling these HBM Class 1B devices.

Typical Performance Curves: $V_{D1,2} = 4\text{ V}$, $I_{D1} = I_{D2} = 90\text{ mA}$

S-Parameters vs. Frequency

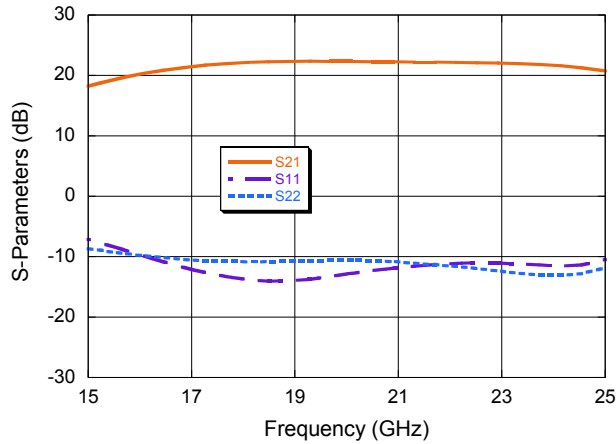

Output / Input IP3 vs. Frequency

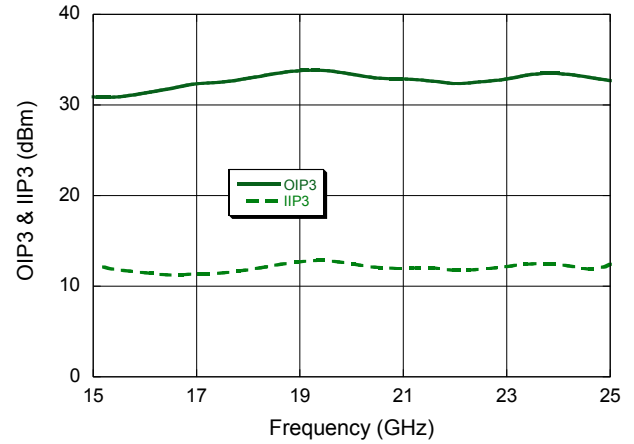

Output P1dB vs. Frequency

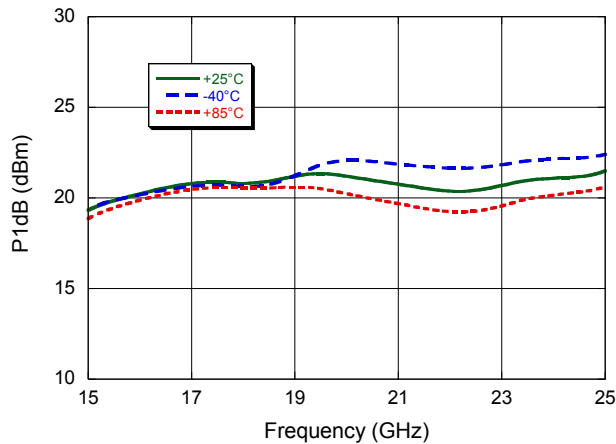

Output IP3 vs. Frequency

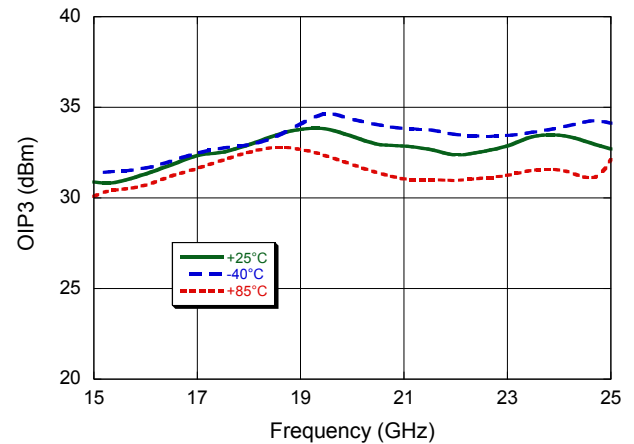

Noise Figure vs. Frequency

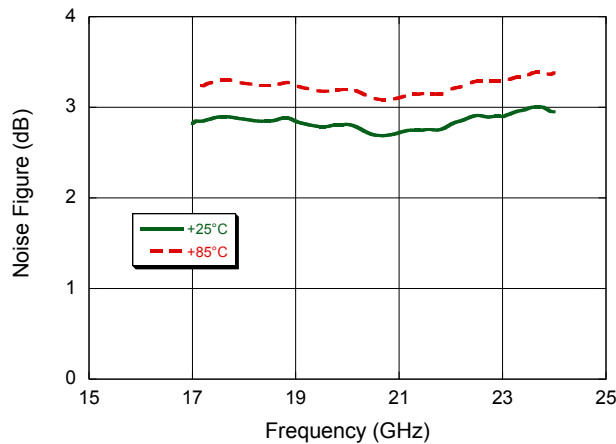

Lead-Free 4 mm 16-Lead PQFN[†]

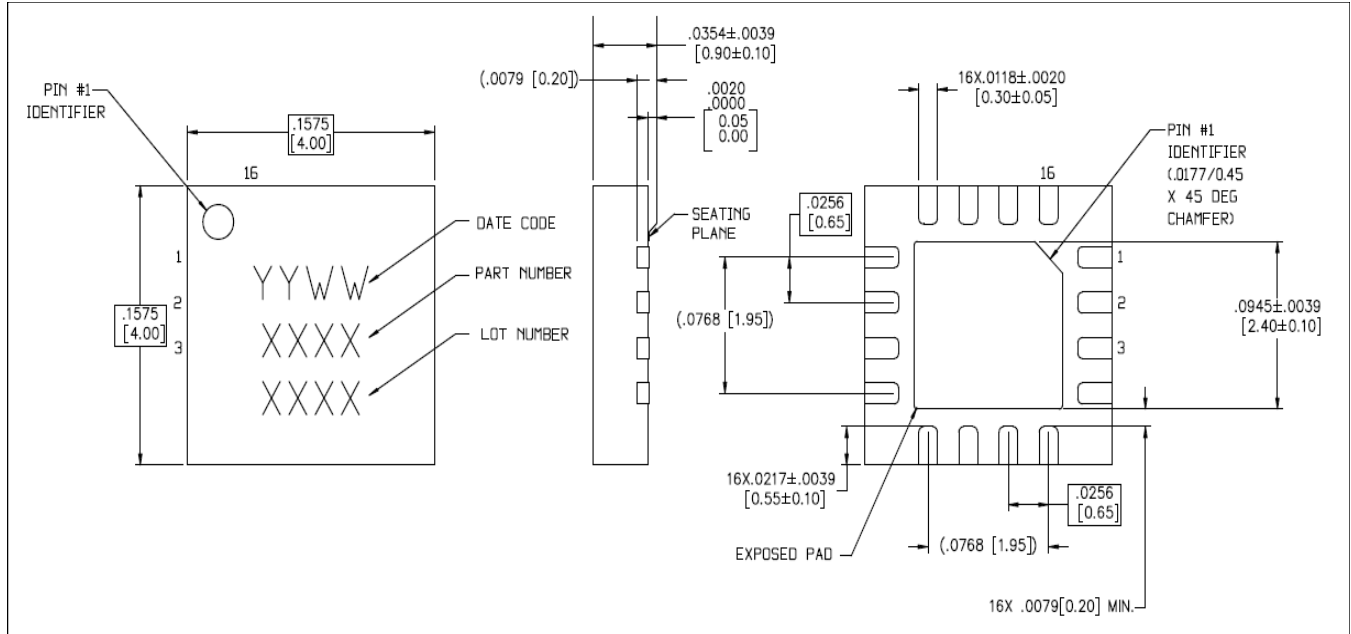

[†] Reference Application Note S2083 for lead-free solder reflow recommendations and PCB footprint information.
Reference JEDEC MO-220,VAR,VGGC for additional dimensional and tolerance information.
Meets JEDEC moisture sensitivity level 1 requirements
All dimensions shown as in/mm

M/A-COM Technology Solutions Inc. All rights reserved.

Information in this document is provided in connection with M/A-COM Technology Solutions Inc ("MACOM") products. These materials are provided by MACOM as a service to its customers and may be used for informational purposes only. Except as provided in MACOM's Terms and Conditions of Sale for such products or in any separate agreement related to this document, MACOM assumes no liability whatsoever. MACOM assumes no responsibility for errors or omissions in these materials. MACOM may make changes to specifications and product descriptions at any time, without notice. MACOM makes no commitment to update the information and shall have no responsibility whatsoever for conflicts or incompatibilities arising from future changes to its specifications and product descriptions. No license, express or implied, by estoppels or otherwise, to any intellectual property rights is granted by this document.

THESE MATERIALS ARE PROVIDED "AS IS" WITHOUT WARRANTY OF ANY KIND, EITHER EXPRESS OR IMPLIED, RELATING TO SALE AND/OR USE OF MACOM PRODUCTS INCLUDING LIABILITY OR WARRANTIES RELATING TO FITNESS FOR A PARTICULAR PURPOSE, CONSEQUENTIAL OR INCIDENTAL DAMAGES, MERCHANTABILITY, OR INFRINGEMENT OF ANY PATENT, COPYRIGHT OR OTHER INTELLECTUAL PROPERTY RIGHT. MACOM FURTHER DOES NOT WARRANT THE ACCURACY OR COMPLETENESS OF THE INFORMATION, TEXT, GRAPHICS OR OTHER ITEMS CONTAINED WITHIN THESE MATERIALS. MACOM SHALL NOT BE LIABLE FOR ANY SPECIAL, INDIRECT, INCIDENTAL, OR CONSEQUENTIAL DAMAGES, INCLUDING WITHOUT LIMITATION, LOST REVENUES OR LOST PROFITS, WHICH MAY RESULT FROM THE USE OF THESE MATERIALS.

MACOM products are not intended for use in medical, lifesaving or life sustaining applications. MACOM customers using or selling MACOM products for use in such applications do so at their own risk and agree to fully indemnify MACOM for any damages resulting from such improper use or sale.