

VI TELEFILTER**Filter specification****TFS 140 P****1/5****1. Measurement condition :**

Ambient temperature T_A : 45 °C
 Input power level: 0 dBm
 Terminating impedances in f_C : for input: 50 Ω | 0 pF.
 for output: 50 Ω | 0 pF.

2. Characteristics :

Remark: Reference level for the relative attenuation a_{rel} of the **TFS 140 P** is the minimum of the pass band attenuation a_{min} . The minimum of the pass band attenuation a_{min} is defined as the insertion loss a_e . The centre frequency f_C is the arithmetic mean value of the upper and lower frequencies at the 6 dB filter attenuation level relative to the insertion loss a_e . The temperature coefficient of frequency Tc_f is valid both for the reference frequency f_C and the frequency response of the filter in the operating temperature range.

Data		typ. value	tolerance / limit
Insertion loss : (Reference level)	a_e	25,8 dB	max. 27 dB
Centre frequency at ambient temperature $T_A = 45$ °C :	f_C	140,00 MHz	140 \pm 0,15 MHz
Centre frequency at room temperature $T_A = 23$ °C :	f_C	140,22 MHz	
Pass band : (see theoretical ¹⁾ frequency response)	PB		$f_C - 9,922$ MHz ... $f_C + 9,922$ MHz
Pass band tilt :		0,0 dB/MHz	max. 0,01 dB/MHz
Deviation from theoretical frequency response at ambient temperature $T_A = 45$ °C ¹⁾ (p-p) :			$\Delta\alpha$
$f_C - (1-a) f_Y$... $f_C + (1-a) f_Y$ or [$f_C - 9,922$ MHz ... $f_C + 9,922$ MHz]		\pm 0,17 dB	\pm max. 0,2 dB
$f_C - f_Y$... $f_C + f_Y$ or [$f_C + 12,100$ MHz ... $f_C + 12,100$ MHz]		\pm 0,3 dB	\pm max. 0,5 dB
Relative attenuation at ambient temperature : a_{rel}			
$f_C \pm 15$ MHz ... $f_C \pm 120$ MHz		60...45	min. 40 dB
Group delay (mean value in PB):	τ_c	1,3 μ s	-
Group delay ripple in PB (p-p):		20 ns	-
Deviation from linear phase in PB :		\pm 1,5 degree	\pm max. 2 °
Reflected attenuation compared to main signal		60 dB	min. 45 dB
Crosstalk attenuation compared to main signal		52 dB	min. 45 dB
Nyquist frequency	f_Y	12,10 MHz	
Roll-off factor	a	0,18	
Partitioning factor	p	0,5	
Input power level	-		max. 15 dBm
Temperature coefficient of frequency :	Tc_f	- 72 ppm / K	
Frequency deviation of f_C over temperature :		$\Delta f_C(\text{Hz}) = Tc_f(\text{ppm/K}) \times (T - T_A) \times f_C (\text{MHz})$	
Operating temperature :			+ 45 °C
Operable temperature range :			- 40 °C ... + 85 °C
Storage temperature range :			- 40 °C ... + 85 °C

¹⁾ Theoretical frequency response :

$$H(x) = (S(x))^p; \quad \text{where } x = \frac{f - f_C}{f_Y}$$

$$S(x) = \begin{cases} 1 & \text{for } |x| \leq (1-a) \\ \frac{1}{2} + \frac{1}{2} \cos\left(\frac{\pi(|x| - 1 + a)}{2a}\right) & \text{for } (1-a) \leq |x| \leq (1+a), \\ 0 & \text{for } (1+a) \leq |x| \end{cases}$$

Generated: W. Dunzow

Checked/Approved: Dr. Bert Wall

VI TELEFILTER

Potsdamer Straße 18

D 14 513 TELTOW / Germany

Tel: (+49) 3328 4784-0 / Fax: (+49) 3328 4784-30

E-Mail: tft@telefilter.com

VI TELEFILTER reserves the right to make changes to the product(s) and/or information contained herein without notice. No liability is assumed as a result of their use or application. No rights under any patent accompany the sale of any such product(s) or information.

3. Construction and pin connection : (all dimensions in mm) pin grid 1,91 mm

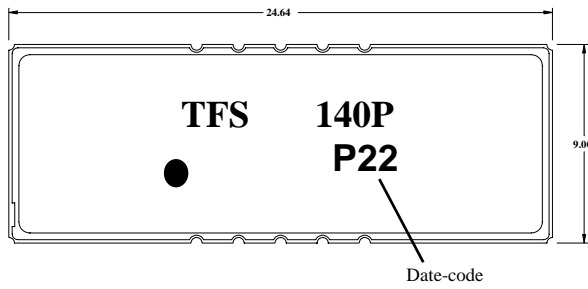

Date-code:	Year+week
M	2000
N	2001
P	2002
...	...

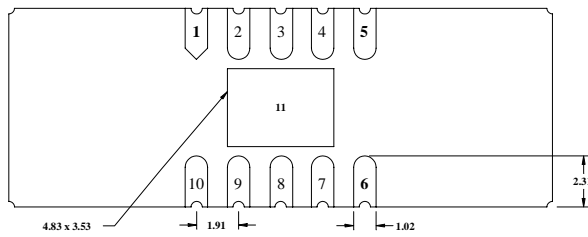
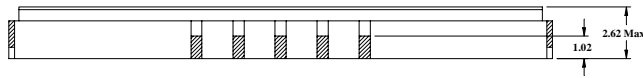

Pin 1	Input
Pin 10	Input RF Return
Pin 6	Output
Pin 5	Output RF Return
Pin 2-4, 7-9	Package Ground

4. 50 Ω matching networks (please refer to the application note for further details) :

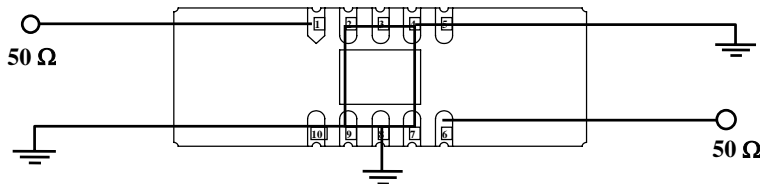

Scheme 1.

5. Stability characteristics :

After the following tests the filter shall meet the whole specification:

1. Shock: 500g, 18 ms, half sine wave, 3 shocks each plane;
DIN IEC 68 T2 - 27
2. Vibration: 10 Hz to 500 Hz, 0,35 mm or 5g respectively, 1 octave per min, 10 cycles per plan, 3 plans;
DIN IEC 68 T2 - 6
3. Change of temperature: -55 °C to 125°C / 30 min. each / 10 cycles
DIN IEC 68 part 2 – 14 Test N
4. Resistance to solder heat (reflow): reflow possible: twice max.;
for temperature conditions, please refer to the attached "Air reflow temperature conditions" on page 4;

6. Packing :

Tape & Reel: DIN IEC 286 - 3, with exception of value for N and minimum bending radius;
tape type II, embossed carrier tape with top cover tape on the upper side;

max. pieces of filters per reel:	1000
reel of empty components at start:	min 300 mm
reel of empty components at start including leader:	min 500 mm
Trailer	min 300 mm

Tape (all dimensions in mm)

W	:	44	± 0,3
Po	:	4	± 0,1
Do	:	1,5	+ 0,1
E	:	1,75	± 0,1
So	:	40,4	± 0,1
P2	:	2	± 0,15
P1	:	16	± 0,1
D1(min)	:	2,0	
Ao	:	9,3	± 0,1
Bo	:	24,9	± 0,1
Ko	:	2,0	± 0,1
t	:	0,35	± 0,05
CT	:	38,0	± 0,1

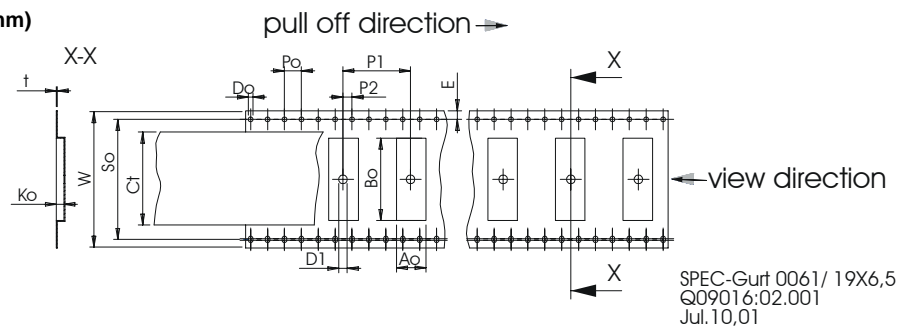
**Reel (all dimensions in mm):**

A	:	330
W1	:	44,4 + 2/-0
W2(max)	:	50,4
N(min)	:	100
C	:	13,0 +0,5 / -0,2

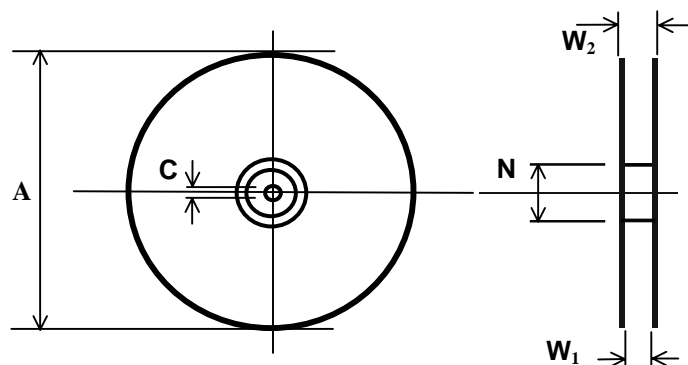

The minimum bending radius is 45 mm. The mounting surface of the filters faces the bottom side of the embossed carrier tape. The marking of the filters is able to read if the view is directed on the upper side of the carrier tape in the above shown direction.

VI TELEFILTER

Potsdamer Straße 18

D 14 513 TELTOW / Germany

Tel: (+49) 3328 4784-0 / Fax: (+49) 3328 4784-30

E-Mail: tft@telefilter.com

VI TELEFILTER reserves the right to make changes to the product(s) and/or information contained herein without notice. No liability is assumed as a result of their use or application. No rights under any patent accompany the sale of any such product(s) or information.

6. Air reflow temperature conditions :

1st and 2nd air reflow profile

Name:	pre-heating periods	main-heating periods	peak temperature
Temperature:	150 °C - 170 °C	over 200 °C	255 °C ± 5 °C
Time:	60 sec. - 90 sec.	20 sec. - 25 sec.	

Chip-mount air reflow profile

Table for temperature vs. time during the air reflow process

Tolerance of temperatures: ± 5 °C

time / sec.	temperature / °C	time / sec.	temperature / °C
0	23	140	160
10	34	150	161
20	46	160	164
30	60	170	170
40	80	180	180
50	103	190	205
60	121	195	230
70	134	200	255
80	143	205	230
90	150	210	205
100	154	215	180
110	156	220	165
120	158	230	140
130	159	240	120

VI TELEFILTER**Potsdamer Straße 18****D 14 513 TELTOW / Germany****Tel: (+49) 3328 4784-0 / Fax: (+49) 3328 4784-30****E-Mail: tft@telefilter.com**

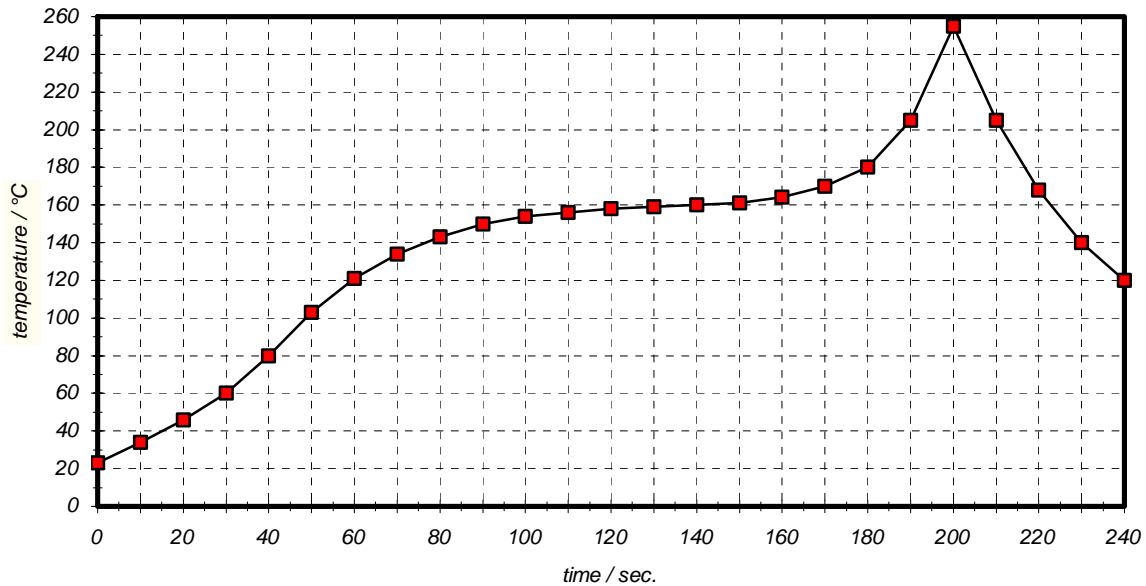
VI TELEFILTER reserves the right to make changes to the product(s) and/or information contained herein without notice. No liability is assumed as a result of their use or application. No rights under any patent accompany the sale of any such product(s) or information.

7. History :

Version	Reason of Changes	Name	Date
1.0	- generate development specification according to customer requirements.	Dunzow W.	25.03.2002
1.1	- change pin connection according to customer requirements. - define " Temperature coefficient of frequency " : $T_{Cf} = -72 \text{ ppm / K}$ - define " Pass band (PB) " : $f_C - (1-a) f_Y \dots f_C + (1-a) f_Y$ or $[f_C - 9,922 \text{ MHz} \dots f_C + 9,922 \text{ MHz}]$ - define " Deviation from linear phase in PB " : $\text{max. } \pm 2^\circ$	Dunzow W.	02.04.2002
1.2	- correct "Deviation from theoretical frequency response at ambient temperature $T_A = 45 \text{ }^\circ\text{C}^{-1}$ (p-p) " :	Dunzow W.	08.04.2002
1.3	- add typical value of filter. - change tolerance value for insertion loss: from $\text{max. } 26 \text{ dB}$ to $\text{max. } 27 \text{ dB}$.	Dunzow W.	02.12.2002

VI TELEFILTER**Potsdamer Straße 18****D 14 513 TELTOW / Germany****Tel: (+49) 3328 4784-0 / Fax: (+49) 3328 4784-30****E-Mail: tft@telefilter.com**

VI TELEFILTER reserves the right to make changes to the product(s) and/or information contained herein without notice. No liability is assumed as a result of their use or application. No rights under any patent accompany the sale of any such product(s) or information.