

ULTRA MINIATURE PRECISION OCXO MV199

Features:

- Ultra miniature package 20.35x20.35x12.7 mm
- High stability vs. temperature: up to $\pm 1 \times 10^{-9}$
- Long term stability up to $\pm 3 \times 10^{-8}$ /year
- Available as RoHS
- Frequency range: 8.192 – 20.0 MHz

Power supply	Output
12V	SIN
5V	HCMOS

ORDERING GUIDE: MV199 – C 3 F – 12V – SIN – 10.0 MHz - LN

Availability of certain stability vs. operating temperature range		$\pm 5 \times 10^{-9}$	$\pm 3 \times 10^{-9}$	$\pm 2 \times 10^{-9}$	$\pm 1 \times 10^{-9}$
		5	3	2	1
A	0...+55 °C	A	A	A	C
B	- 10...+60 °C	A	A	C	C
C	- 20...+70 °C	A	A	C	C
D	- 40...+70 °C	A	A	C	NA
EX	- 40...+85 °C	A	C	NA	NA

A – available, NA – not available, C – consult factory

For other temperature ranges see designation at the end of Data Sheet.

Package drawing:

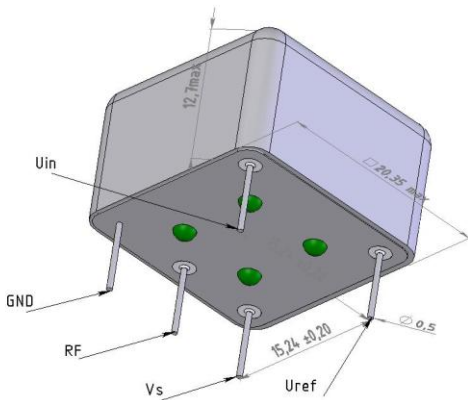

Availability of certain aging values for certain frequencies		Standard frequencies				
		10.0 MHz	12.8 MHz	13.0 MHz	16.384 MHz	20.0 MHz
H	$\pm 2 \times 10^{-7}$ / year	NA	NA	NA	A	A
G	$\pm 1 \times 10^{-7}$ / year	A	A	A	A	C
F	$\pm 5 \times 10^{-8}$ / year	A	A	A	C	NA
E	$\pm 3 \times 10^{-8}$ / year	A	C	C	NA	NA

A – available, NA – not available, C – consult factory

Phase noise, dBc/Hz, for 10MHz, SIN	-	LN
		For 12V, SIN
1 Hz	<-95	<-100
10 Hz	<-125	<-130
100 Hz	<-145	<-150
1000 Hz	<-150	<-155
10000 Hz	<-155	<-160

Short term stability (Allan deviation) per 1 sec, for 10 MHz	$< 5 \times 10^{-12}$ $< 2 \times 10^{-12}$ (opt.)
Frequency stability vs. load changes ($\pm 5\%$)	$< \pm 5 \times 10^{-10}$
Frequency stability vs. power supply changes ($\pm 5\%$)	$< \pm 5 \times 10^{-10}$
Warm-up time within accuracy of $< \pm 2 \times 10^{-8}$ @ 25 °C	<3 min
Optional*, within accuracy of $< \pm 1 \times 10^{-7}$ @ 25 °C	<1 min

Power supply (Us)	12V $\pm 5\%$	5V $\pm 5\%$
Steady state current consumption @ 25°C	<100 mA	<250 mA
Peak current consumption during warm-up (for "D" temp. range)	<400 mA	<650 mA
Frequency pulling range (for 10 MHz)	$> \pm 4.0 \times 10^{-7}$	
Control voltage range (Uin)	0...5 V	0...4.5V
Reference voltage (Uref)	+5 V	+4.5 V

Output	HCMOS	SIN
Level	"0" <0.5V "1" >4.0V	>300 mV
Load	10kOhm/30pF	50 Ohm $\pm 5\%$
Rise/Fall time	<6 ns (<3 ns optional)	-
Harmonics	-	>30 dBc

Vibrations:	
Frequency range	10-500 Hz
Acceleration	5 g
Shock:	
Acceleration	75 g
Duration	3 ± 1 ms
Humidity @ 25 °C	98%
Storage temperature range	-55...+85 °C

Additional notes:

- Please consult factory for daily aging values. Normally typical correspondence of daily to aging per year is as following: $\pm 1 \times 10^{-7}$ /year – $\pm 1 \times 10^{-9}$ /day; $\pm 5 \times 10^{-8}$ /year – $\pm 5 \times 10^{-10}$ /day; $\pm 3 \times 10^{-8}$ /year – $\pm 3 \times 10^{-10}$ /day
- Please mention RoHS requirement (if any) while requesting for quote or while placing PO.
- For non standard operating temperature ranges please use the following two letters designations (first letter for the lower limit, second letter for the upper limit), °C:

A	B	C	D	E	F	G	H	J	K	L	M	N	P	Q	R	S	T	U	W	X
-60	-55	-50	-45	-40	-30	-20	-10	0	+10	+30	+40	+45	+50	+55	+60	+65	+70	+75	+80	+85