



N 2-Way Power Divider 1-18GHz



Wide Band Power Divider

- Very small package
- Excellent phase and amplitude balance
- Bi-Directional as divider and combiner *
- Low Insertion loss and high isolation
- Standard: MIL E-5400, MIL E -16400
- High power handling capability
- * 5W maximum input when work as combiner.

Electrical Specifications				
Frequency (GHz)	Insertion Loss (dB)	Isolation (dB)	Phase unbalance (degree)	Amplitude Unbalance (dB)
1.0-18.0	1.4	16	5.0	0.3
Forward Power (W)	Impedance (Ω)	Reverse Power (W)	Input VSWR	Output VSWR
30	50	2	1.5	1.5

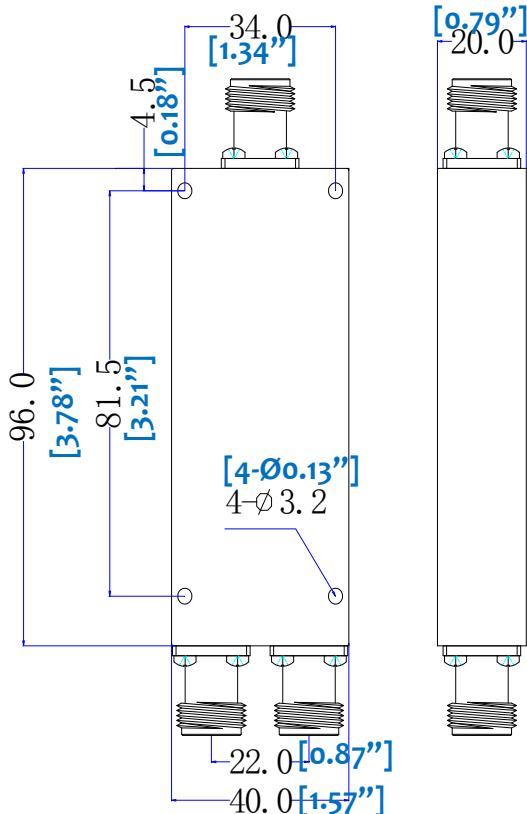

Environmental Specifications:

- Operating Temperature: -30 °C~+70° C
- Storage Temperature: -55 °C~+95° C

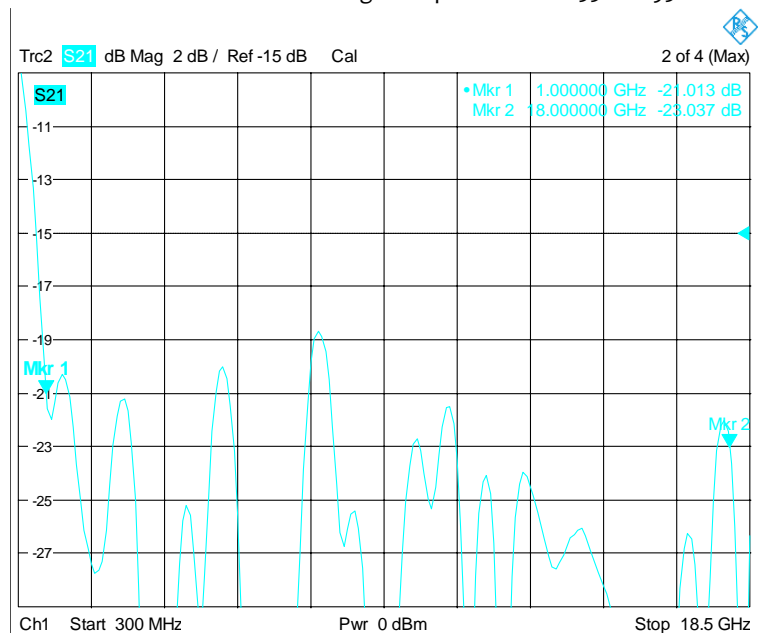

1.0GHz-18GHz 2-Way N Type Power Divider

